

ROOF MAKER

WORLD CLASS ROOFLIGHTS



PRODUCT SPECIFICATION AND INSTALLATION GUIDE

FIXED CONSERVATION LUXLITE™

FIXED CONSERVATION LUXLITE™: STANDARD PRODUCT SPECIFICATION

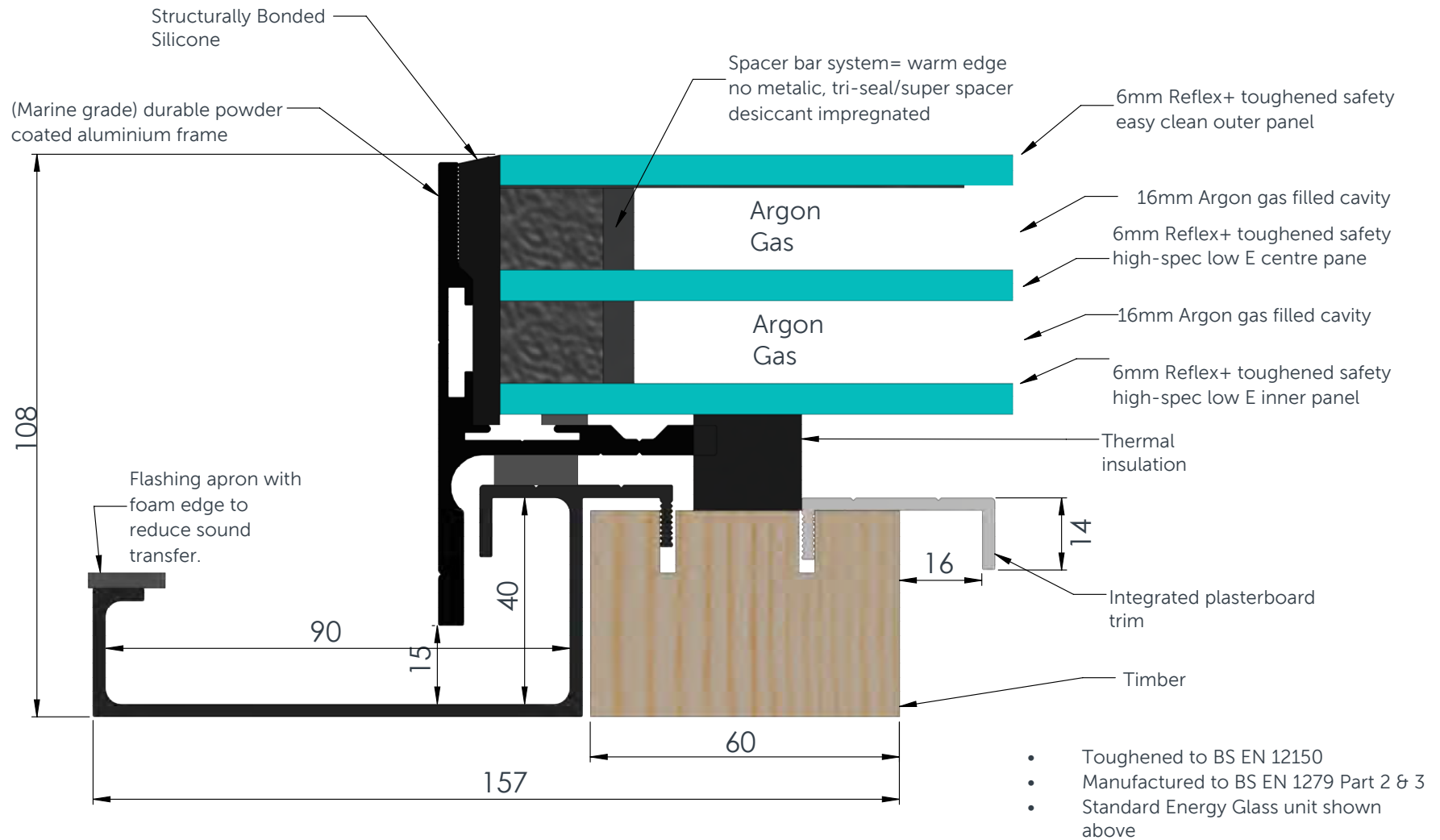

CONSERVATION LUXLITE™: SPLIT BAR CONFIGURATION GUIDE

This guide shows the number of split bars that will be structurally bonded to the surface of the glass as standard, which is dependent on the width of your Conservation Luxlite™. This will be the same for both fixed and opening variations. However, the number of split bars can be increased or decreased based on your specific requirements, which can be discussed with a member of the sales team when you make an enquiry.

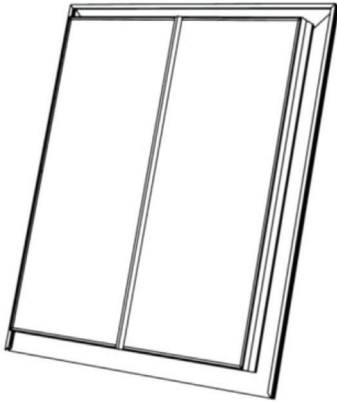
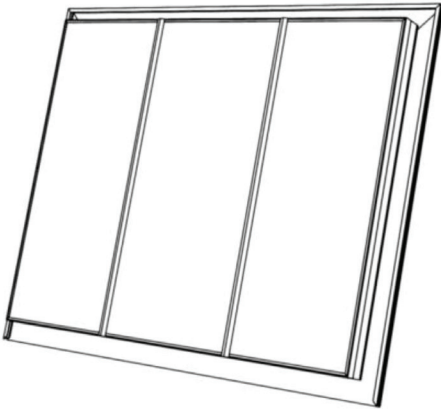
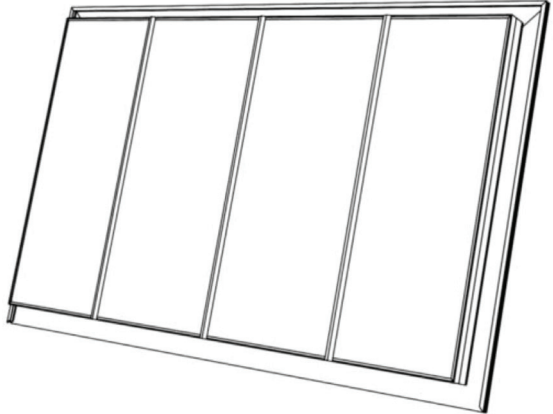
Number of split bars:	1 split	2 splits	3 splits
Width of rooflight:	400mm - 1000mm	1001mm - 1500mm	1501mm - 2000mm
Image:			

Continued overleaf...

CONSERVATION LUXLITE™: SPLIT BAR CONFIGURATION GUIDE

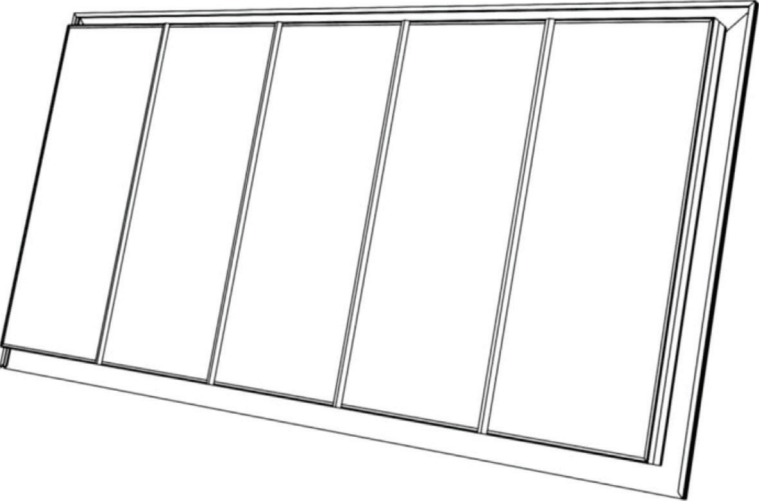
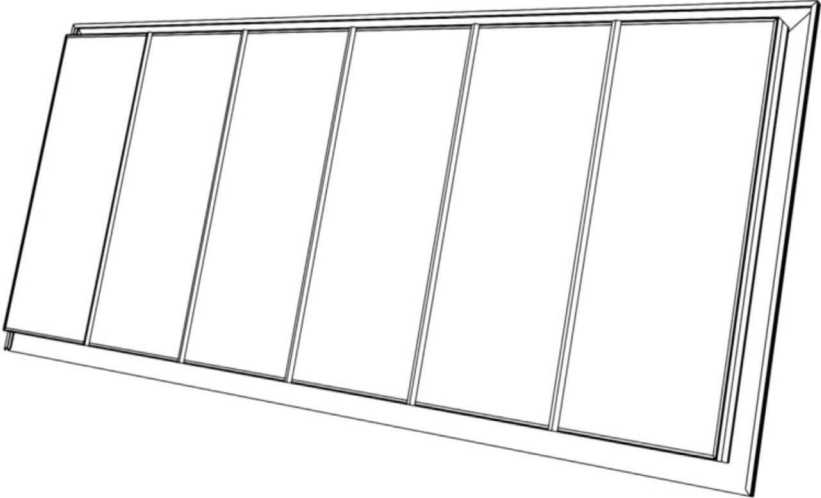
Number of split bars:	4 splits	5 splits
Width of rooflight:	2001mm - 2500mm	2501mm - 3000mm
Image:	 A line drawing of a rectangular rooflight with a white frame and a white base. It is divided into four equal-width vertical sections by four vertical split bars. The rooflight is shown at an angle, tilted upwards from the bottom left.	 A line drawing of a rectangular rooflight with a white frame and a white base. It is divided into five equal-width vertical sections by five vertical split bars. The rooflight is shown at an angle, tilted upwards from the bottom left.

FIXED CONSERVATION LUXLITE™:INSTALLATION INSTRUCTIONS

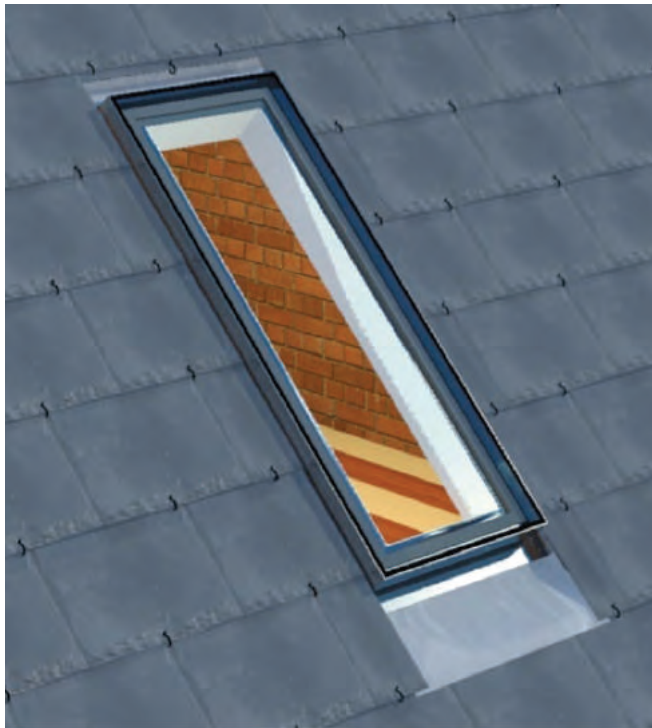

INSTALLATION GUIDE

Make sure to read through all steps and understand all requirements before beginning assembly.

In addition to your Luxlite™ you will need:

- Silicone Adhesive Sealant
(high quality; Dow Corning 791 suggested)
- Drill, bits and screws as required

Please take precaution when moving heavy objects and working at height; be sure to use correct equipment.

GUIDE WEIGHTS Triple Glazed	
Size (mm)	Weight (kg)
400x400	27
600x600	43
900x700	63
1400x700	88
1000x1000	87
1500x1000	120
2000x1000	152
2400x1000	178
3000x1000	217
1500x1200	138
2000x1200	175
2400x1200	205

PLEASE NOTE - weights stated can vary and work to a +/- 10% tolerance. We can provide weights for sizes not listed

ROOF MAKER

WORLD CLASS ROOFLIGHTS

Call us: 0116 269 6297
Mon-Fri 9-5pm

STEP ONE

FIT TRIMMERS TO YOUR RAFTERS

The internal dimensions of the aperture created by your trimmers and rafters should match the size of the Luxlite™ you ordered. (e.g. for 2000x1000mm Luxlite™, the internal dimensions of your aperture should be 2000x1000mm).

Fit trimmers across the rafters adjacent to the aperture, and a beam across the trimmers, as shown. These additional structural members will support the tile battens around the rooflight.



Internal aperture

STEP TWO

FIT UNDERFELT TO YOUR ROOF

Fit underfelt to your roof. The underfelt should extend to the rim of the aperture where your Luxlite™ will be installed. Seal the underfelt to the timber around the aperture.

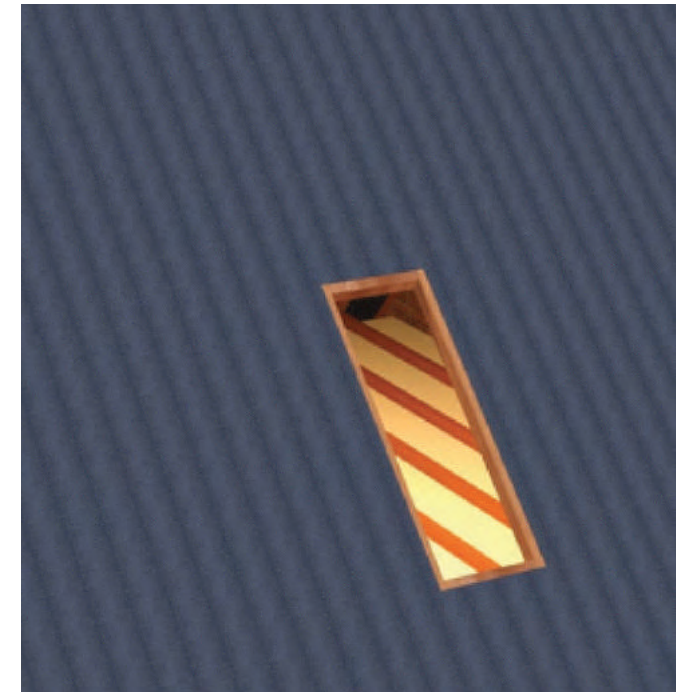

ROOF MAKER

WORLD CLASS ROOFLIGHTS

Call us: 0116 269 6297
Mon-Fri 9-5pm

STEP THREE

PREPARE AND FIT A WEDGE BELOW THE APERTURE

The bottom of the wedge should meet level with the tiles that will be installed later. This can be determined by trial fitting the Luxlite™ assembly. The wedge should be at least as wide as the Luxlite™ apron. The position and angle of the wedge is dependent on the roof type set out.



STEP FOUR

COVER THE WEDGE WITH FLASHING

Cover the wedge installed in the previous step with flashing (flashing and wedge not provided). The flashing width should be at least 100mm (either side) greater than the Luxlite™ apron. It is also important that the highlighted edge of the flashing (left) is tucked underneath the Luxlite™ apron.



STEP FIVE

BRING YOUR LUXLITE™ INTO POSITION

Bring your Luxlite™ into position and align it so that it is centred on your aperture.

Seal the interface between the Luxlite™ and the aperture with silicone.

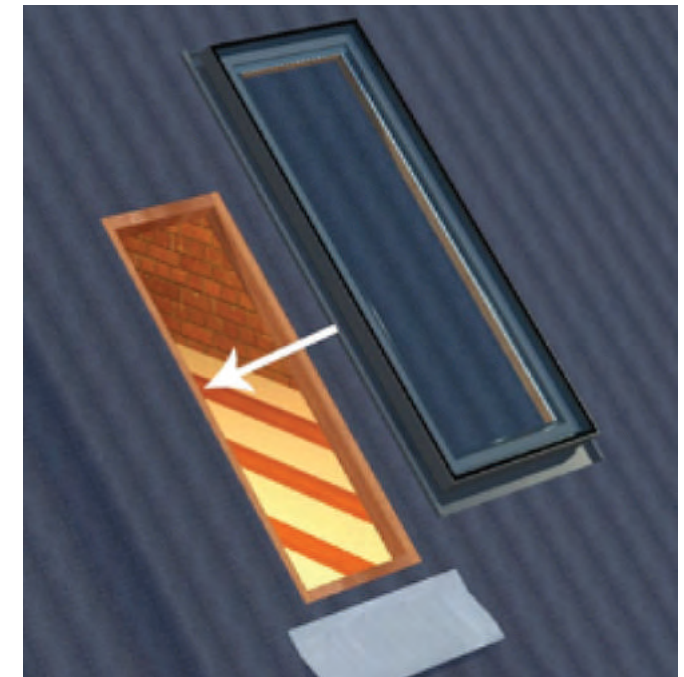

ROOF MAKER

WORLD CLASS ROOFLIGHTS

Call us: 0116 269 6297
Mon-Fri 9-5pm

STEP SIX

FIX YOUR LUXLITE™ TO YOUR ROOF

Use the brackets provided to fix your Luxlite™ to your roof. Refer to the assembly section view in the appendix at the end of this document for more detail.



STEP SEVEN

FIT TILE BATTENS TO YOUR ROOF

Tile battens can now be fitted to your roof. The battens should be flush with the edge of the Luxlite™ aluminium apron.



STEP EIGHT

FIT FLASHING TO COVER THE BATTENS

Seal beneath the lip of the apron, drape over battens. Tiles will sit over this flashing. (Note: side flashing is only required when using pantiles).

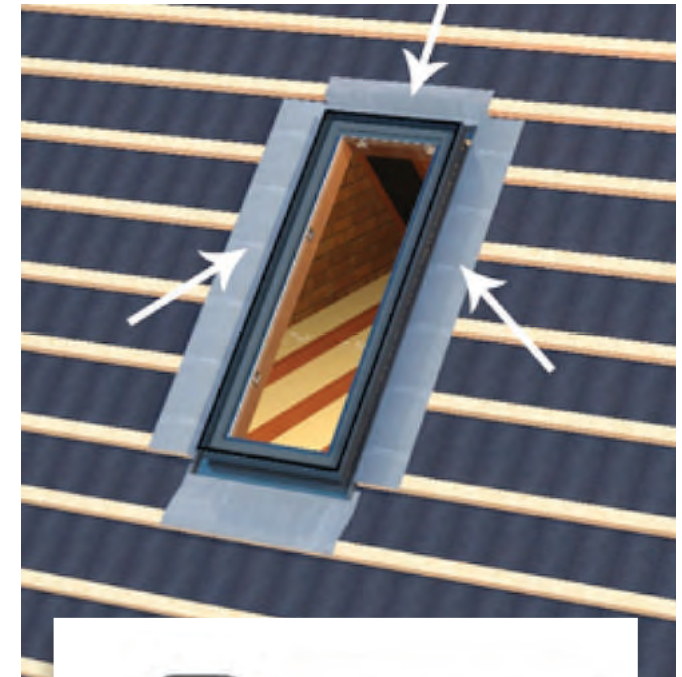

ROOF MAKER

WORLD CLASS ROOFLIGHTS

Call us: 0116 269 6297
Mon-Fri 9-5pm

STEP NINE

FIT TILES TO YOUR ROOF

You are now free to fit tiles to your roof. The Luxlite™ has been designed so that your roof tiles can overlap the apron, leaving little aluminium exposed for a minimalistic aesthetic.



STEP TEN

PLASTERBOARD TO FINISH YOUR LUXLITE™ ASSEMBLY

Apply plasterboard to the internal faces of your aperture. The plasterboard is to be applied up to the internal trim of the Luxlite™ (for plastering finish guidelines, please follow the cross section fitting guide, included at the end of this document).

Congratulations! Your Conservation Luxlite™ is now fully installed.



ROOF MAKER

WORLD CLASS ROOFLIGHTS

Call us: 0116 269 6297
Mon-Fri 9-5pm

ROOF SECTION FITTING GUIDE

