

ROOF MAKER

WORLD CLASS ROOFLIGHTS



PRODUCT SPECIFICATION & INSTALLATION GUIDE

FLAT PACKED SLIMLINE® ROOF LANTERN

4 PANE CONFIGURATION

DOUBLE GLAZED SLIMLINE® LANTERN STANDARD PRODUCT SPECIFICATION

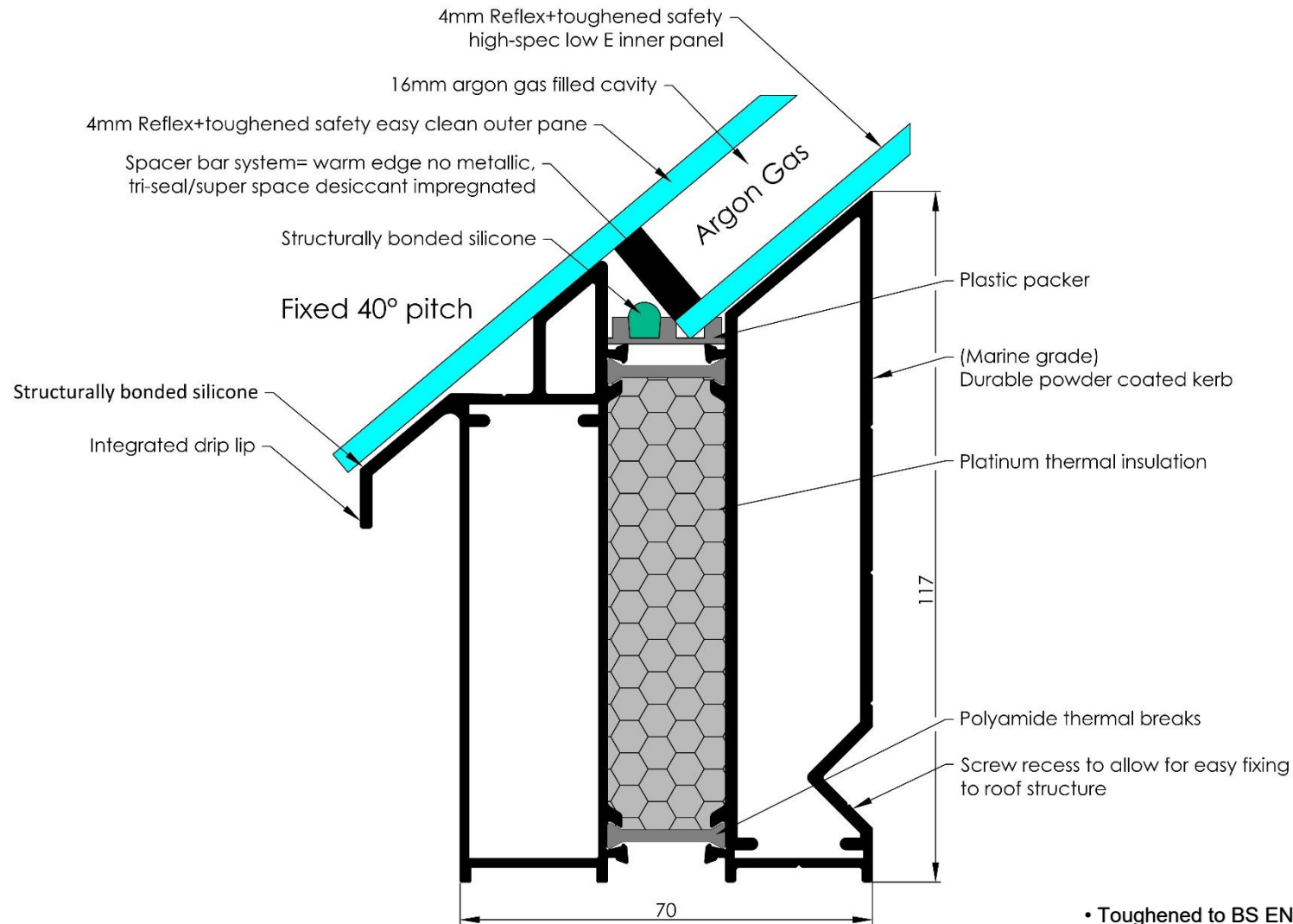

- Toughened to BS EN 12150
- Manufactured to BS EN 1279 Part 2 & 3
- Standard Energy Glass unit shown above

TRIPPLE GLAZED SLIMLINE® LANTERN STANDARD PRODUCT SPECIFICATION

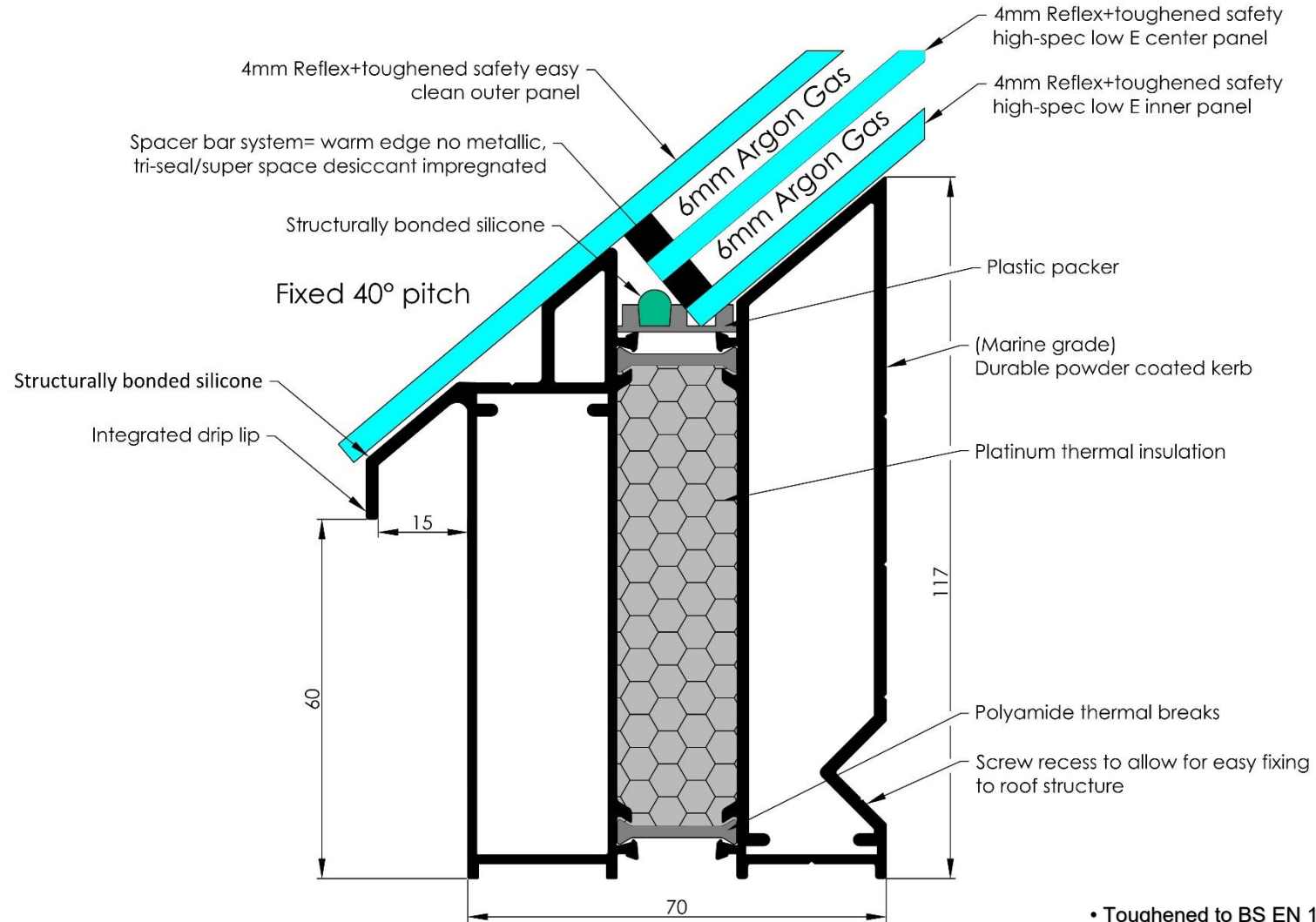

- Toughened to BS EN 12150
- Manufactured to BS EN 1279 Part 2 & 3
- Standard Energy Glass unit shown above

SLIMLINE® STEP-BY-STEP INSTALLATION GUIDE

THANK YOU FOR CHOOSING ROOF MAKER, WE HOPE YOU ARE DELIGHTED WITH YOUR NEW ROOFLIGHT.

Our roof lanterns have been designed with speed and ease of construction in mind, so that you don't need to be a professional installer to build and fit them.

This guide will take you through an easy-to-follow process to ensure you build and install your roof lantern correctly, but if you do need advice or help, our technical support team are available to provide guidance.

PLEASE NOTE: For roof lanterns that feature blackout blinds, there is a blackout blind wiring guide available which we can provide, or is available to download in the technical section on our website. This also outlines the additional components that you will receive, such as the remote control and power pack.

GUIDE WEIGHTS FOR THE SLIMLINE® ROOF LANTERN*

SLIMLINE® ROOF LANTERN		
Size (mm)	Double glazed Weight (KG)	Triple glazed Weight (KG)
600 x 400	20	24
1000 x 700	42	53
1500 x 1000	76	99
2000 x 1000	97	128
2500 x 1000	118	156
3000 x 1000	139	185
3500 x 1000	160	214
4000 x 1000	181	243
5000 x 1000	223	300
1500 x 1200	87	115
2000 x 1200	112	149
2500 x 1200	136	182
6000 x 1200	390	538
3000 x 1500	193	262
3500 x 1500	222	303
4000 x 1600	266	364
5000 x 1600	328	451
3000 x 2000	247	339
4000 x 2000	322	445

THE GUIDE EXPLAINED

This guide covers the installation of a Slimline® roof lantern with a 4-pane configuration.

If your Slimline® roof lantern has additional panes and splits in the glazing, you will need to follow the 'Slimline® Additional Glazing Splits' installation guide instead. If you haven't received this, it is available to download from the technical section on our website.

If you have an opening vent(s) specified in your lantern, you will need to follow the 'Slimline® With Vent(s)' installation guide instead. If you haven't received this, it is available to download from the technical section on our website.

WHAT DO I NEED TO CONSTRUCT MY ROOF LANTERN?

IN ADDITION TO YOUR SLIMLINE® ROOF LANTERN, YOU WILL NEED:

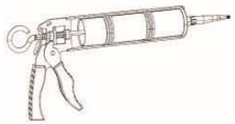

Silicone adhesive sealant (recommended Dow Corning 791 or similar)- Required for the fixation of your upstand to the prepared timber kerb. **Silicone required when glazing the unit will still be provided as part of your kit.**



Drill with HSS drill bit – To pre-drill the aluminium upstand to form holes for your timber screws when fixing to your timber upstand.



Posi drive and flathead drill bits – For fixing of screws and bolts throughout the assembly.

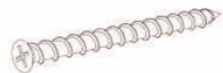

Timber screws – Measuring at least 50mm in length. Required to fit the upstand to the prepared timber kerb.

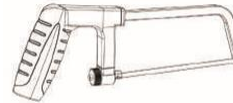

Hacksaw - To trim the plastic cap carriers as advised in the fitting guide.



Rubber mallet – To carefully tap components into place such as carriers and cappings.

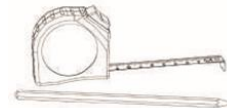

Tape measure and pencil



Stanley knife

Damp cloth – To wipe off any excess silicone as required.

COMPONENT CHECKLIST















The images below show a component checklist that you will receive as part of your flat-packed kit. This will be attached to the box which contains most of your components. Not all of the components listed will be applicable to your chosen specification. Your exact inventory will be outlined, along with quantities, as part of the list. This also includes imagery to help you locate the various components and familiarise yourself with what you will be working with.



Page 1 of 2

SLIMLINE® LANTERN COMPONENT CHECKLIST			
JCB REF # NAME			
FRAME COLOUR			
NUMBER OF GLASS PANE			
SIZE			
PACKED BY (print name)			
CHECKED BY (print name)			

COMPONENTS FOR STANDARD CONFIGURATION LANTERN (NO GLAZING SPLITS)



IMAGE	COMPONENT	QTY	TICK
	Aluminum ridge body (with end blocks and fittings) - prepared with glazing tape		
	Pyramid apex tip attachment block (pyramid lanterns only)		
	Plastic ridge cap carrier		
	Aluminum ridge cap cover		
	Aluminum hip body - prepared with glazing tape		
	Plastic hip cap carrier		
	Aluminum hip cap cover		
	Pre-assembled upstand (prepared with nuts and bolts for hip body attachment)		
	Aluminum ridge end caps		
	Aluminum pyramid apex cap (pyramid lanterns only)		
	Plastic glazing packers		
	Aluminum hip end caps		
	Black countersink screws		
	Adjuster (in case adjustment of ridges required)		
	Sealant tube		









Page 2 of 2

SLIMLINE® LANTERN COMPONENT CHECKLIST			
JCB REF # NAME			





COMPONENTS FOR ADDITIONAL GLAZING SPLITS/VENT INSTALLATION (IF APPLICABLE)

IMAGE	COMPONENT	QTY	TICK
	T-bar outer (longer than inner T-bar, without gull) prepared with glazing tape		
	T-bar inner - prepared with glazing tape		

COMPONENTS FOR LARGER LANTERN KITS (EXCEEDING 3000 X 1500 WITH UNASSEMBLED UPSTAND SECTIONS) (IF APPLICABLE)

	Upstand section (in lengths)		
	Nut and Bolt		
	Corner cleat type A		
	Corner cleat type B		
	Straight cleat (for large lanterns, joining upstand sections, not on end)		
	Self drilling screws		

COMPONENTS FOR OPENING VENTS (IF APPLICABLE)

	Vent housing (includes winding mechanism or motor)		
	Pre-glazed vent fit		
	Creme winding pole (for manual vents)		
	Rocker switch (if applicable)		
	Cable constraint sensor unit (if applicable)		

Make sure to read through all steps and understand the requirements before beginning assembly.

Please take precautions when moving heavy objects and working at height - be sure to use suitable equipment.

STEP 1 - PREPARE THE TIMBER KERB

i) Before you begin the construction of your new roof lantern, you will have installed the timber kerb. The size of the internal opening should reflect the exact size of the roof lantern you have ordered. For example, the roof opening should measure exactly 2m x 1m for a unit that measures 2m x 1m.

Your timber kerb should measure 70mm in width, to match the width of the built-in upstand that you are going to assemble. We recommend a minimum height of 25mm from roof level, but this can be increased if required.

The upstand should be perfectly level and we also recommend that you check the corners have a 90° angle, by measuring it diagonally from corner to corner before starting the assembly of the roof lantern.

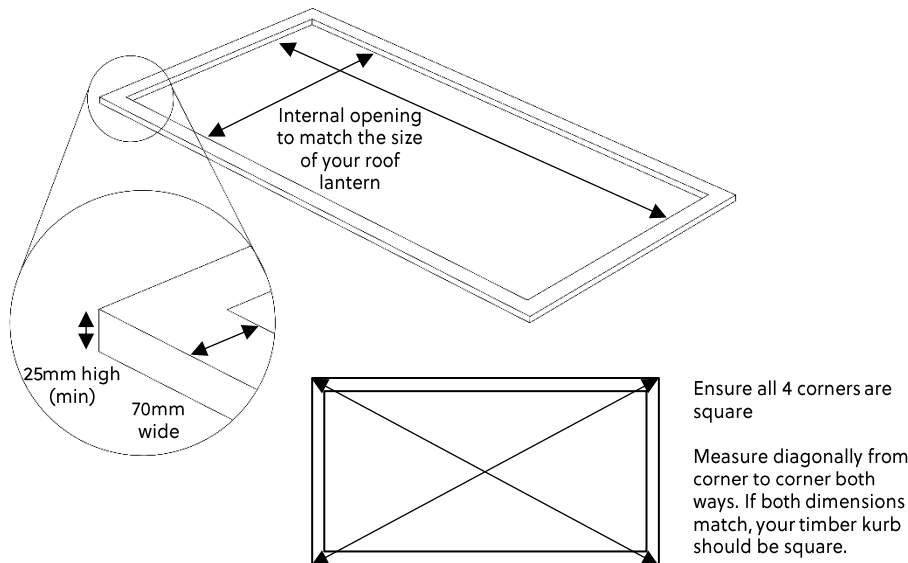

STEP 2 - PREPARE THE ROOF MEMBRANE

i) We recommend that you apply your roof membrane after installing your roof lantern, to avoid damaging or piercing it during the installation.

If you have added your roof membrane on top of your plywood deck already, please ensure that you leave enough excess material around the timber kerb to flash the roof lantern upstand. This can be folded back out of the way until your roof lantern is installed.

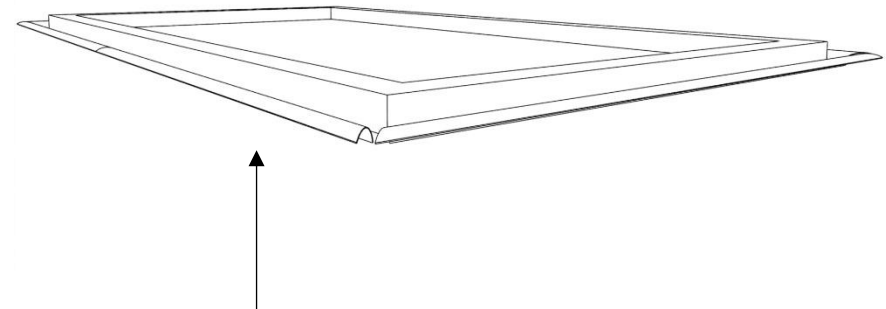

Roof membrane folded back out of the way, leaving the timber upstand exposed for the installation of the roof lantern.

You are now ready to begin the construction of your new roof lantern.

STEP 3 - UPSTAND ASSEMBLY

For most sizes, the built-in, insulated upstand will come ready assembled. But if your roof lantern is larger than 3m x 1.5m you will need to assemble the frame yourself. **If your upstand is pre-assembled, proceed to step 4.**

i) Take two of the corner cleats and insert them into the slots in the frame as shown.

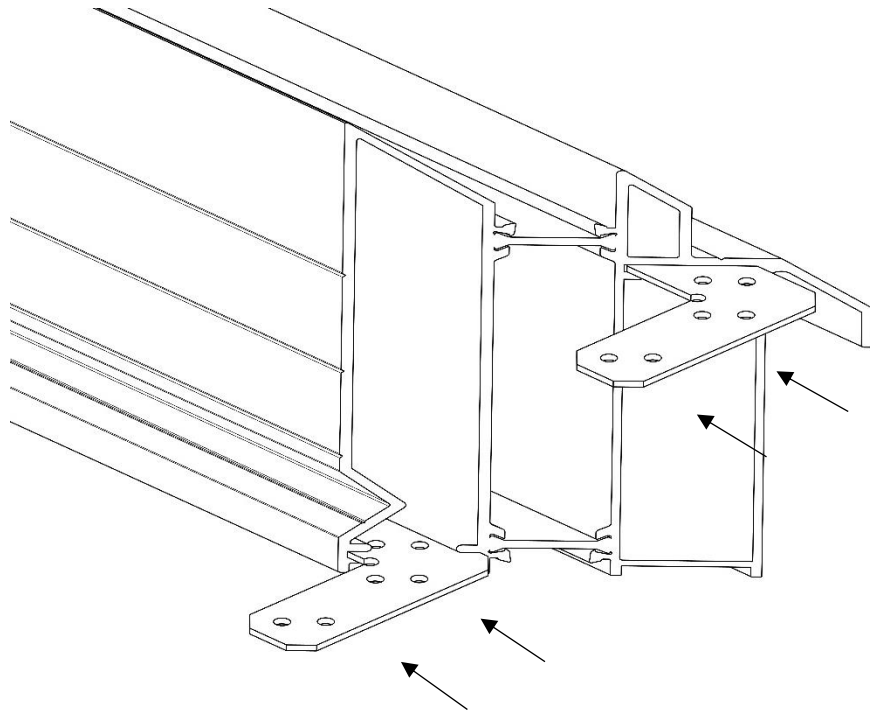

ii) Then take the other ends of the cleats and insert them into the slots of the corresponding piece of the frame. Before you push the two pieces of frame together, make sure that the nut and bolt are placed into the pre-cut hole as shown below.

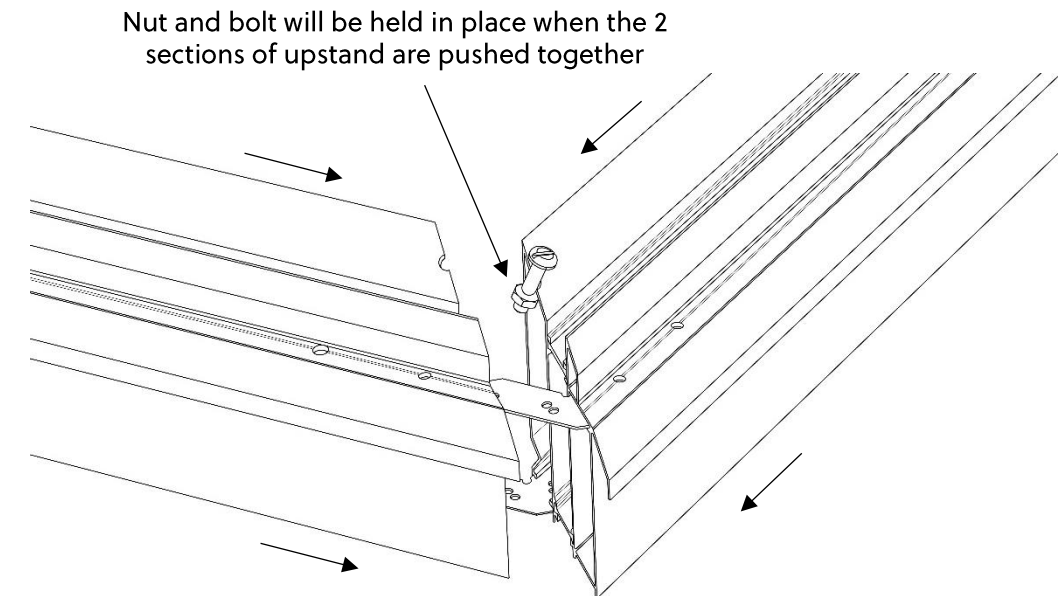

STEP 3 - UPSTAND ASSEMBLY - CONTINUED

iii) Next fasten the frame section together securely using the screws provided through the top of the upstand, through the 4 pre-formed holes. Repeat for all corners.

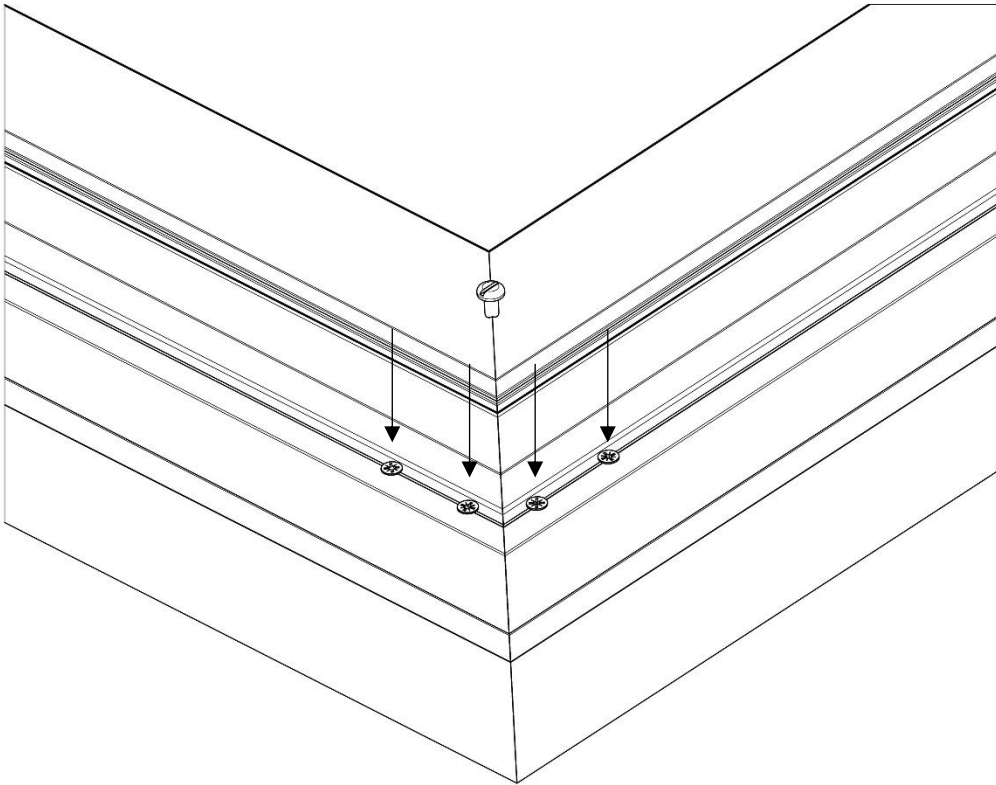

iv) Turn the upstand over and repeat the same process for each corner on the underside of the unit. Fixing the screws through each pre-formed hole. Once complete, the frame should be securely fastened together.

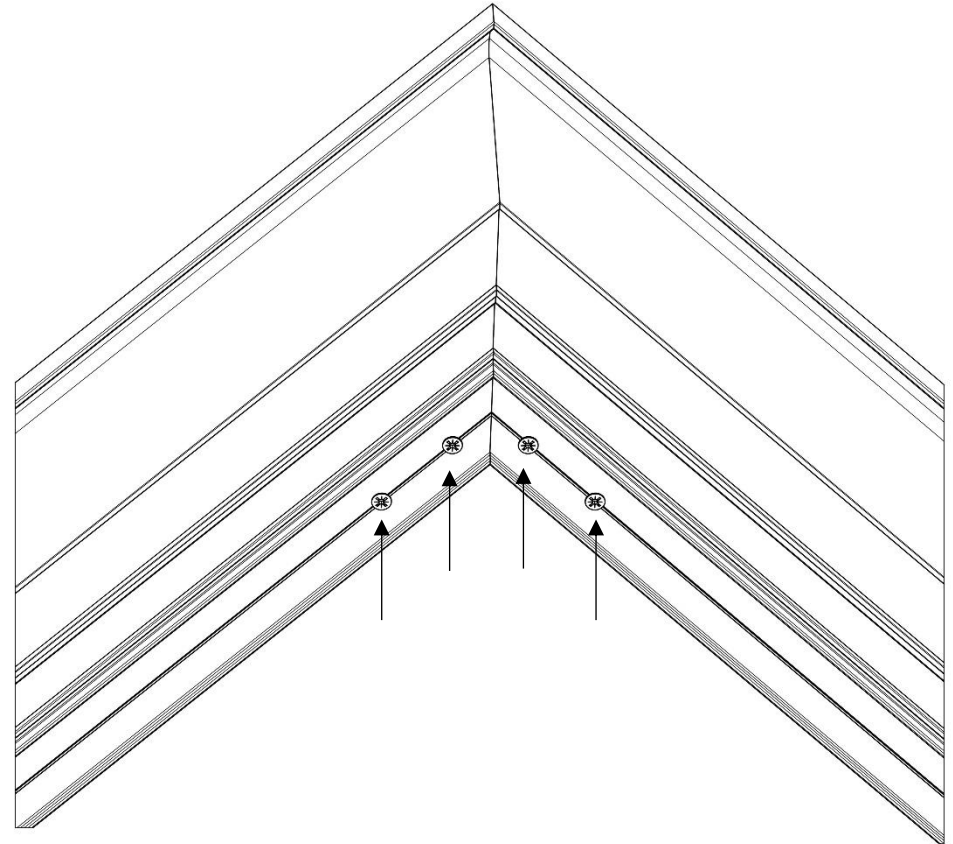

STEP 3.1 - UPSTAND ASSEMBLY FOR UNITS LONGER THAN 3.2M

i) If your roof lantern exceeds 3.2m in length, the upstand section running the length of the unit will come in 2 parts. You will also receive straight cleats, which are used to join these upstand sections together, end on end.

You will just need to insert the cleats into the slots of the upstand sections as you did with the corner cleats. Following the same process, apply the fixings into the topside of the upstand before turning it over to fix the underside. The below diagram illustrates the use of the straight cleats.

There will be 4 pre-formed screw holes on both the top side and underside of the upstand, as per the corner joints of the upstand

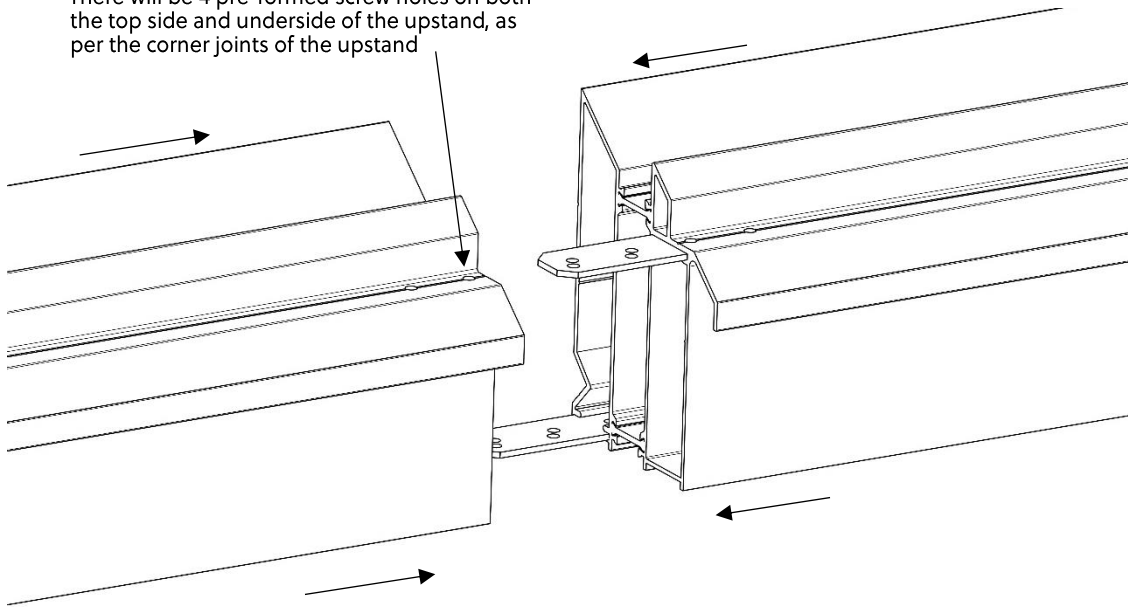

The upstand is now ready to be fixed to your timber kerb.

STEP 4 - FIXING YOUR UPSTAND TO THE TIMBER KERB

i) Apply a thick bead of silicone all the way around the timber kerb about 20mm from the internal edge. Only use a professional quality silicone adhesive sealant such as Dow Corning 791.

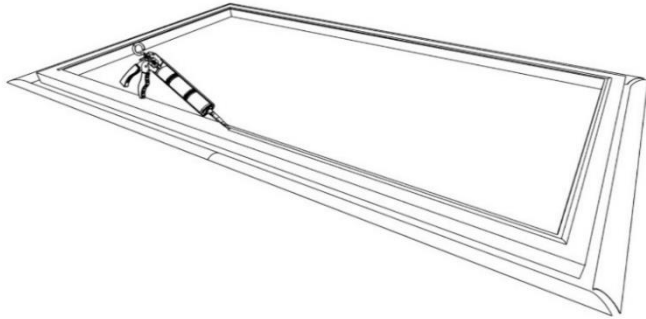

ii) Then carefully place the assembled upstand onto the kerb, ensuring it sits flush with the inner and outer edge of the kerb.

Purpose made groove here to screw-fix the upstand section to your timber kerb (next step)

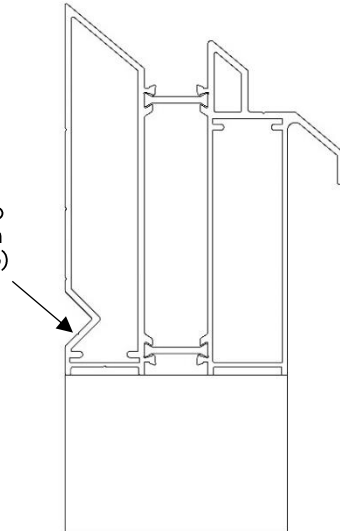

(Section view of your timber Kerb with upstand section Sitting flush on both sides)

iii) You now need to secure the upstand to the timber kerb by inserting screws into the purpose-made groove as shown, about 100mm from each corner, screwing through the upstand into the timber underneath. You will need to predrill your holes into the aluminium frame using a standard metal drill bit.

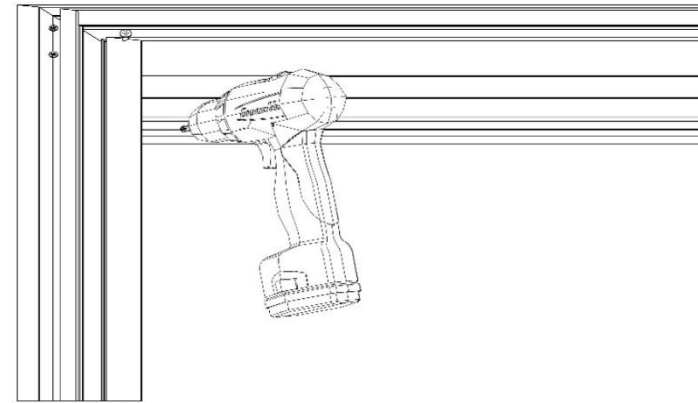

We recommend a minimum of 12 screws – two at each corner, With a further screw in the middle of each side.

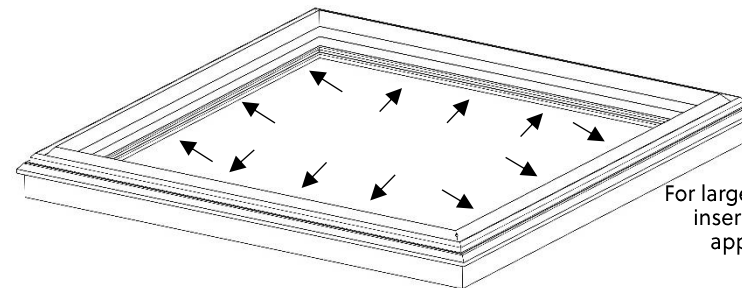

For larger lanterns, we recommend inserting additional screws at approx. 500 mm intervals.

You are now ready to attach the 4 provided hip bodies to the upstand.

STEP 5 - FIXING THE HIP BODIES

i) Bring one of the hip bars into position over the upstand and slide the head of the bolt into the slot of the hip. Please note that the end of the hip bars that have angled corners need to be positioned at the top of the lantern.

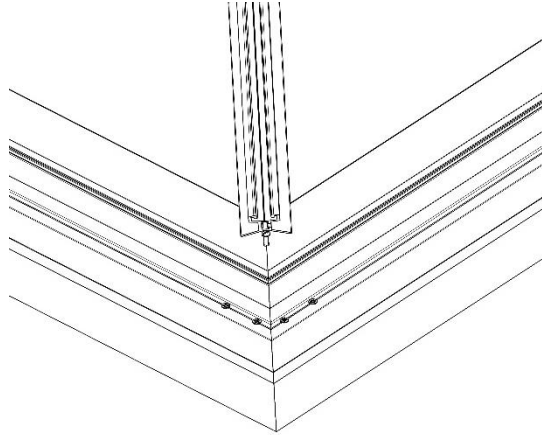

ii) Now pull the hip body toward you whilst tightening the bolt. This will ensure that the internal nut stays in place whilst tightening. Repeat for all 4 corners.

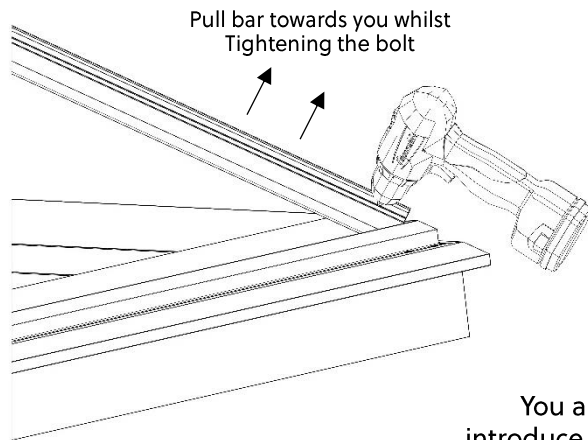

You are now ready to introduce the ridge body.

STEP 6 - FIXING THE RIDGE BODY

i) The ridge body has blocks located at either end which already house the bolts that will connect to your hip bars. Slide the slotted end of the hip bars over the bolts in the ridge end block. Position the hip bars so they connect with each other in line with the centre of the ridge bar as shown. Tighten the bolts, then repeat at the other end.

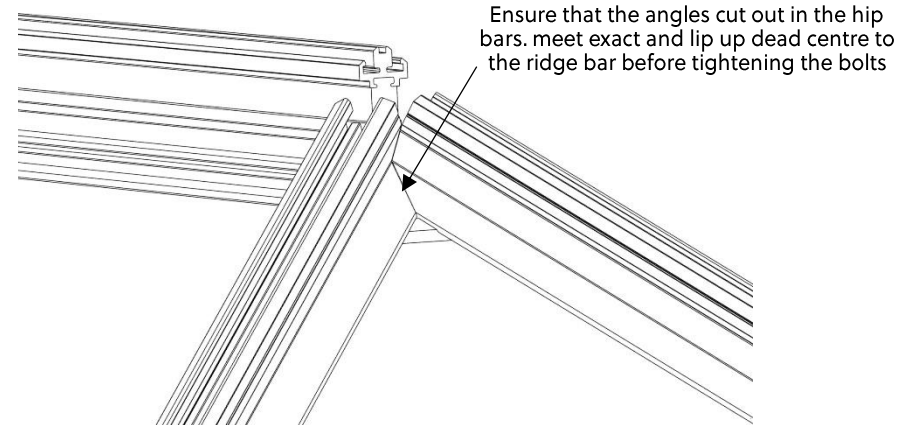
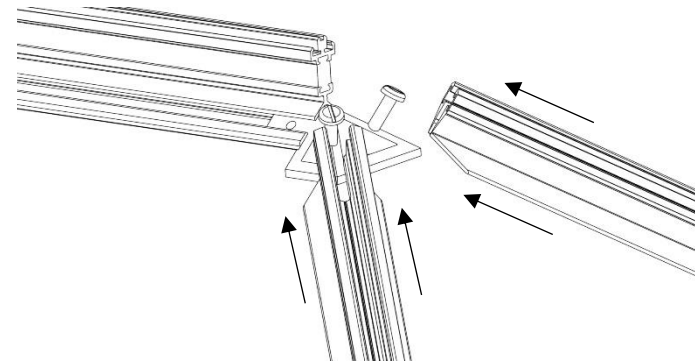

ii) Now remove the blue protective film from each side of the ridge and hip profiles.

STEP 7 - POSITIONING YOUR GLAZING PACKERS

i) Fit the packers at each corner of the upstand, into the groove as shown below. Apply a small spot of silicone either side of the packer to stop them from sliding side to side.

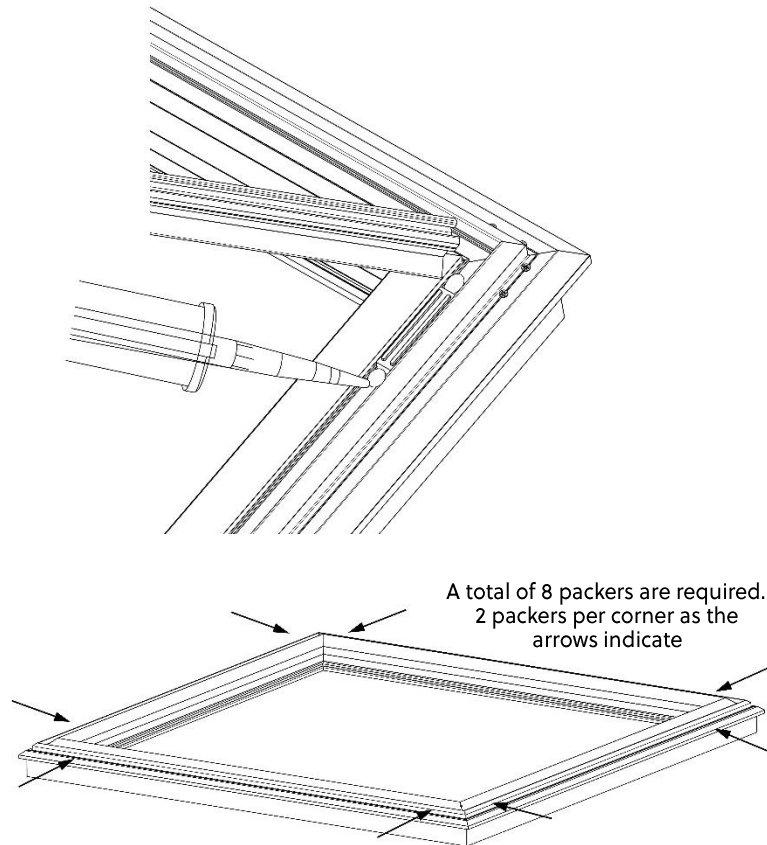

The next stage is to insert the glass sections. The frame is designed so these will fit easily and neatly into place, but care needs to be taken as these are the heaviest components of your roof lantern.

STEP 8 - PEELING BACK THE PROTECTIVE FILM

i) Before you introduce the glass panels to the unit, peel back the first approx. 5cm of the green protective film from the glazing tape that has been pre-applied to your ridge and hip bars. Do this at both ends of the hips and ridge bar as shown. Ensure that this excess film will be accessible from the inside of the roof lantern when the glass is positioned.

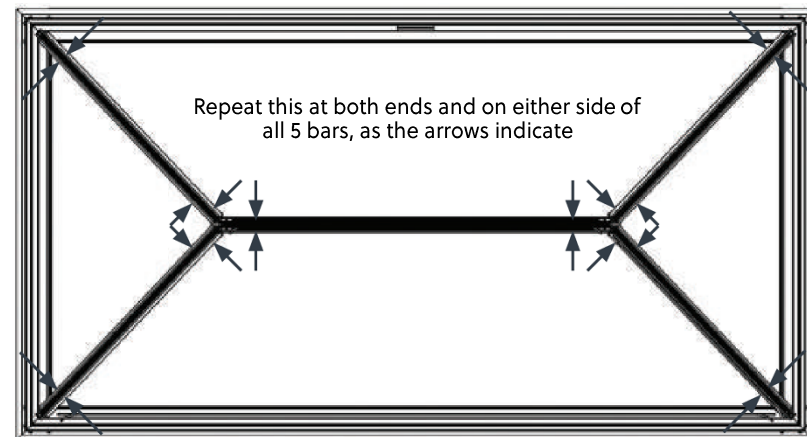
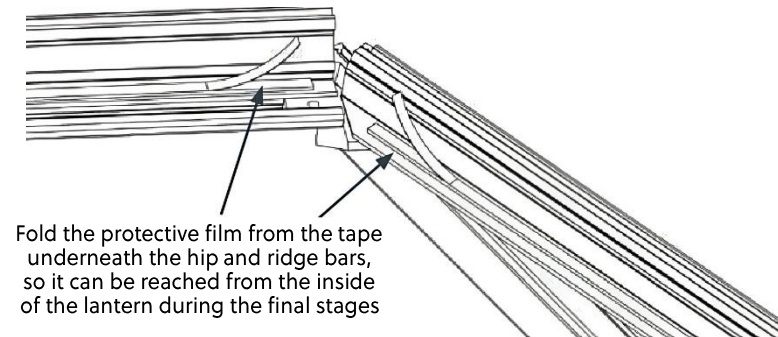

STEP 9 - INSERTING THE GLASS PANELS

i) Bring in one of the panels and sit it on the inside groove of the packers, and then gently lower it into the frame. Repeat this with all 4 panels.

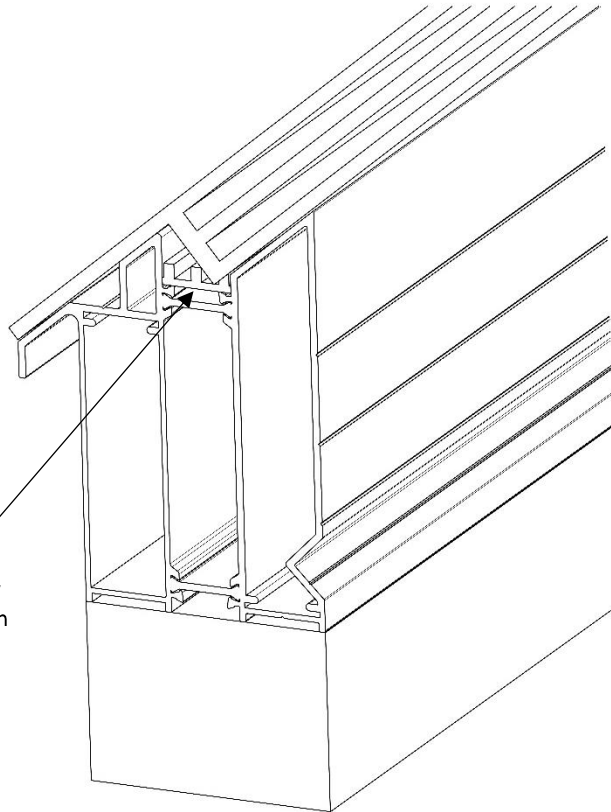

Ensure that you insert the glass into the inside groove of the packer to ensure that the glass sits flush onto the frame. Failure to do this will affect the fitting of your glazing bar cappings later in the installation.

When you are confident that the glass is positioned correctly, you are ready to apply silicone as per the next step.

STEP 10 - APPLYING SILICONE

i) Ensuring that you use the provided Dow Corning 791 silicone, apply a generous amount of silicone into the central groove at the top and bottom of each of the hip profiles running about 100mm from each end of the bars.

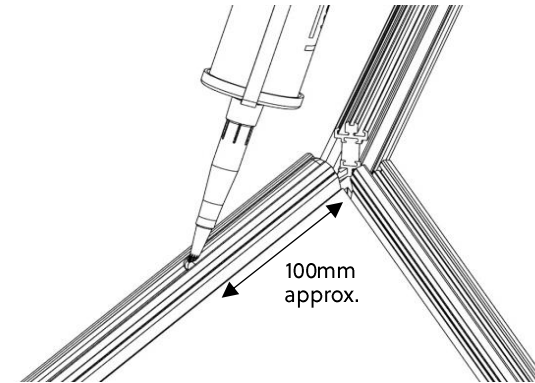

ii) Next run silicone between all the glass panels and frames, on either side of the hip and ridge bars. Only 100mm of silicone is required running from each end of the hip bars. For the ridge bar, run silicone the full length on both sides.

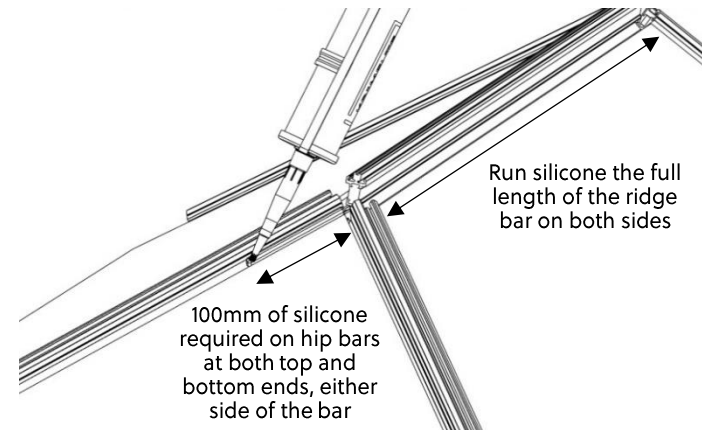

STEP 11 - INTRODUCING THE HIP CARRIERS AND HIP TOP CAPS

i) Prepare your hip carriers and aluminium top caps by sliding them together with the angled part of both pieces being positioned at the same end. These pieces are angled where they will meet at the ridge bar when applied. Stagger the hip carrier so that 100mm is sticking out at the top, as you cannot slide the hip caps up into position until the ridge carrier and top cap is fitted.

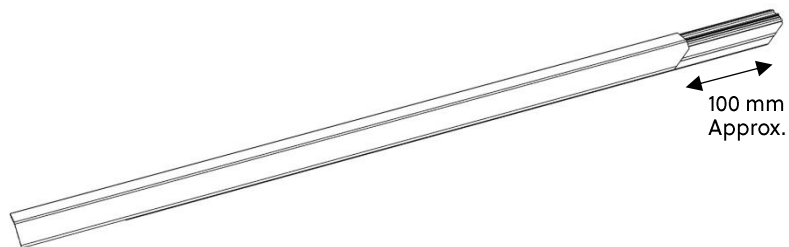

ii) Gently tap the hip carriers and top caps onto the hip bars with your rubber mallet.

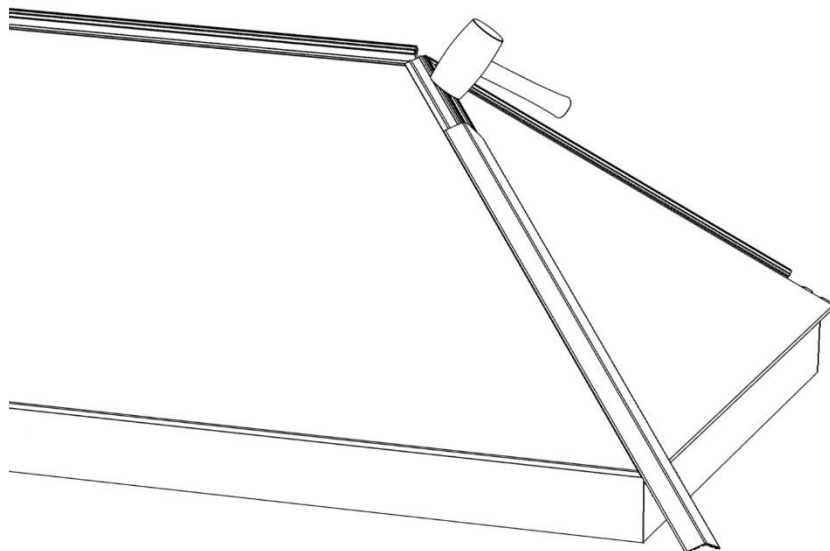

iii) Slide the hip carriers up the hip bar, ensuring that the angled cut-outs line up perfectly and are positioned dead centre to the ridge bar.

Your hip carriers should meet together at the top as pictured and line up with the centre of your ridge bar

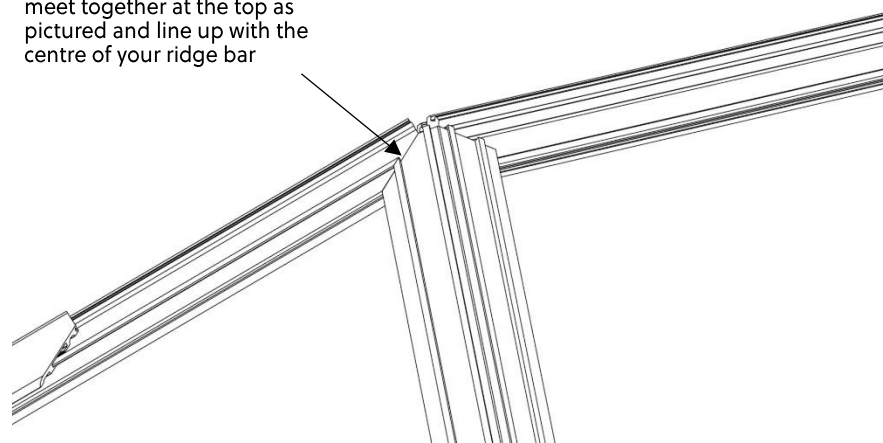

iv) Repeat this process on the other end of the roof lantern.

STEP 12 - PREPARING YOUR PLASTIC RIDGE CARRIER

i) Prepare your ridge carrier by cutting of the corners with a hacksaw, set in from the ends of your ridge carrier by approx. 20mm as the diagram shows. Do this at both ends, making 4 small cuts.

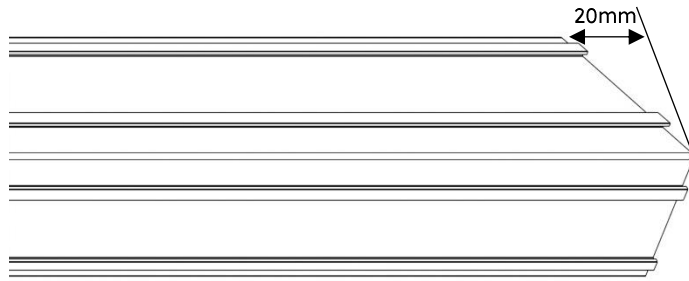

ii) The ends of the ridge carrier might be slightly rough or frayed after doing this, which will affect the ease of sliding your ridge top cap into place during the next step. If this is the case, we advise that you gently shave the ends with a Stanley knife, to create a smoother surface.

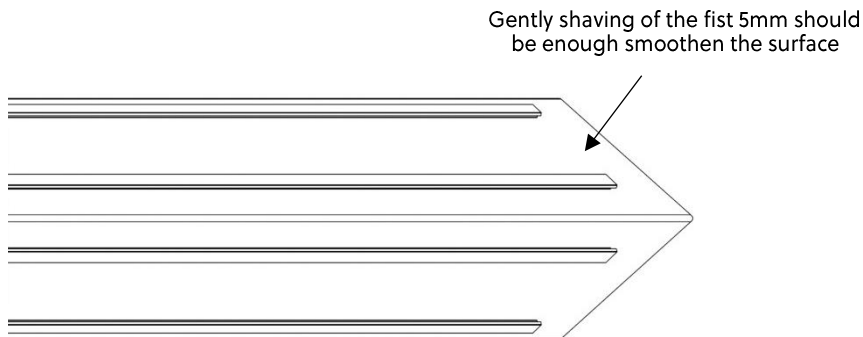

STEP 13 - INTRODUCING THE RIDGE CARRIER AND RIDGE TOP CAP

i) When prepared, bring in your ridge carrier, gently tapping it into place carefully by hand or with your rubber mallet. Ensure it is centred perfectly by checking both ends.



ii) Then slide your ridge top cap in from one end onto the ridge carrier, again, ensuring that it is perfectly centred by checking both ends as shown.

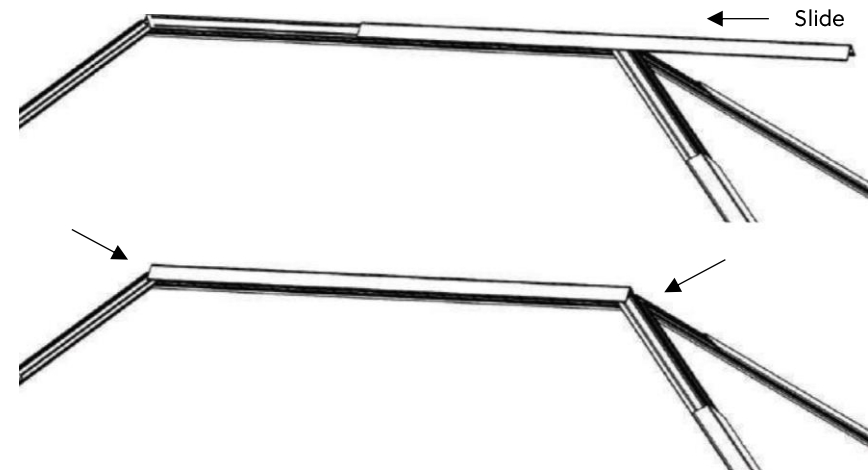

STEP 14 - POSITION THE HIP TOP CAPS

i) You can now slide the hip top caps into position so they meet evenly at the top centre, as you did with the hip carriers. You must ensure that the hips sit underneath the ridge top cap as shown. Repeat on the other side of the roof lantern.

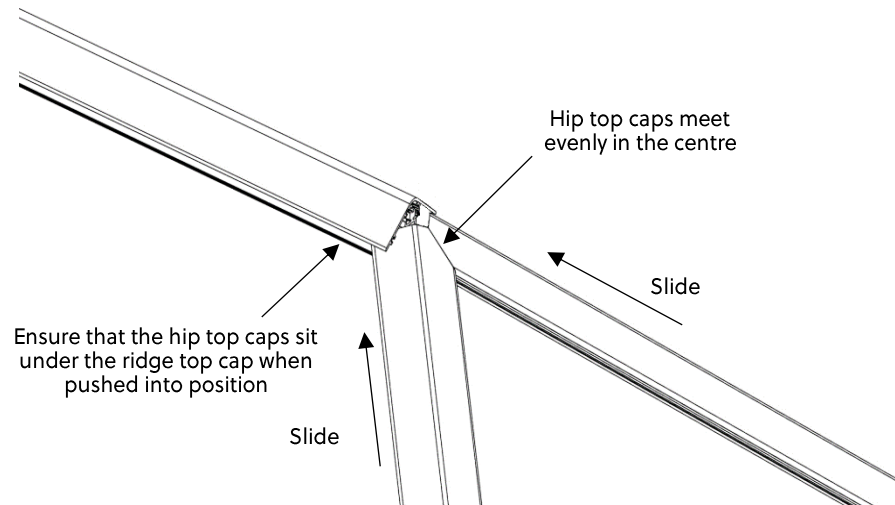

ii) If the plastic hip carrier is protruding from the bottom of the hip bars, use a hacksaw to carefully remove the excess, being careful not to damage the aluminium hip caps. Repeat at each corner if necessary.

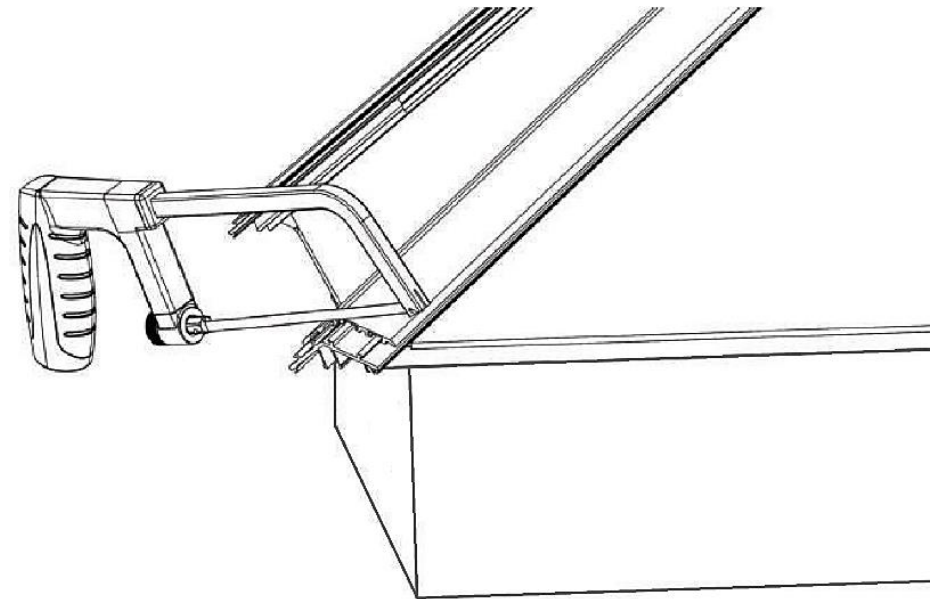

Next, you are ready to fix the 4 provided hip end caps to the bottom of your hip bars.

STEP 15 - FITTING THE HIP AND RIDGE END CAPS

i) Using a screw gun set at a low gear, attach the end caps as shown, being careful not to overtighten them. Repeat at all 4 corners of the lantern.

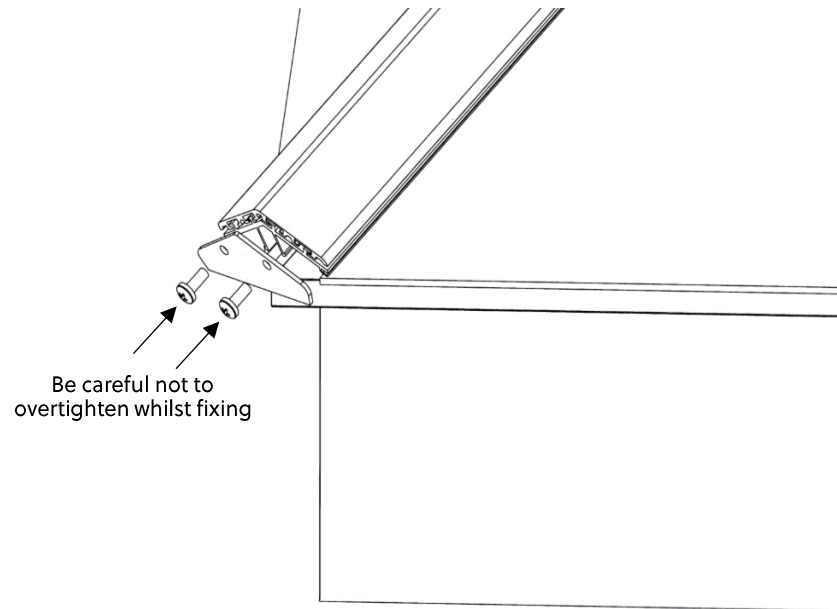

ii) It is now time to fit the two ridge end caps. Fill the space between the end of the ridge cover and the hip caps generously with silicone as shown and apply the two end caps.

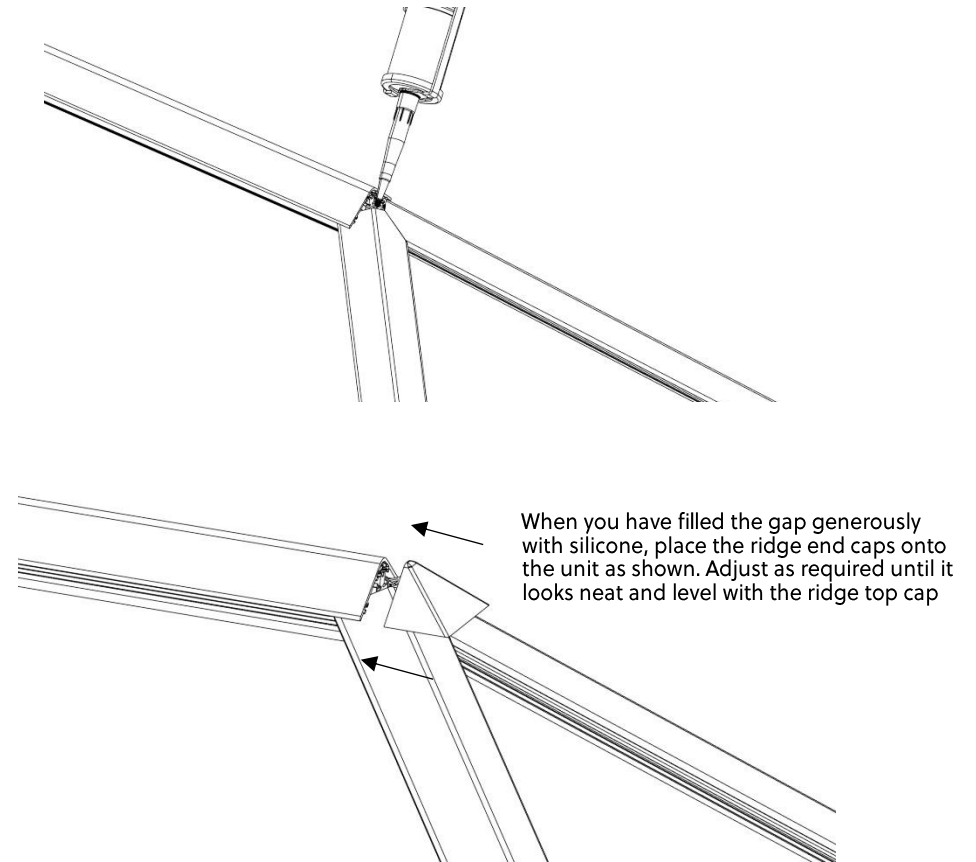

STEP 16 - FINAL STAGE OF ASSEMBLY – SEALING THE UNDERSIDE OF THE GLASS PANELS

i) Your Slimline® roof lantern assembly is now nearly complete. All that remains is to seal the underside of the bottom edge of the glass with silicone, ensuring that the bottom edge of the glass is sealed to the drip lip of the upstand. Repeat this on all 4 sides. Wipe away any excess silicone with a damp cloth.

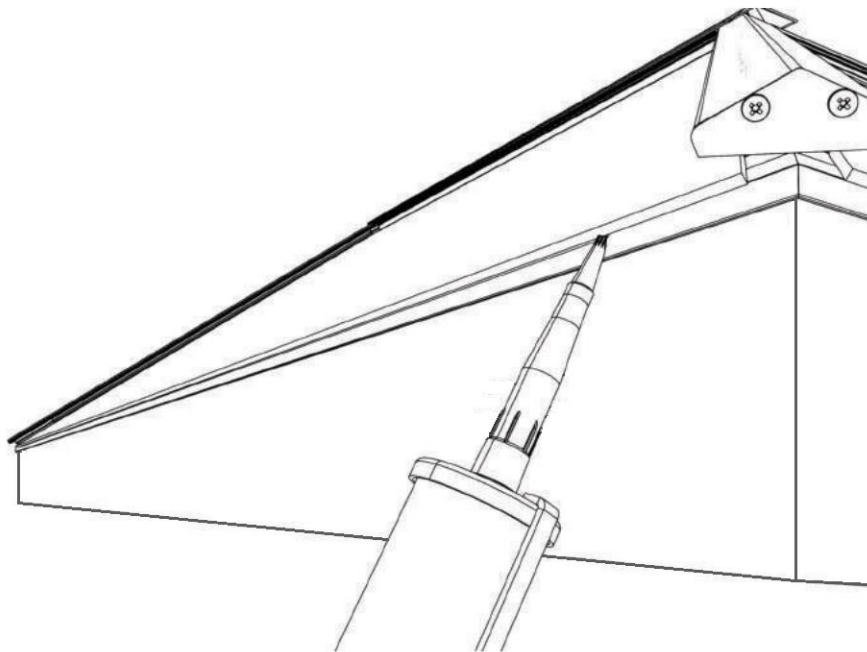

ii) From the inside of the lantern, gently remove all of the protective film from the glazing tape on the hip and ridge bars.

Generously fill here,
between the glass and
frame on all 4 sides of the
unit. Finish by wiping
away any excess silicone.

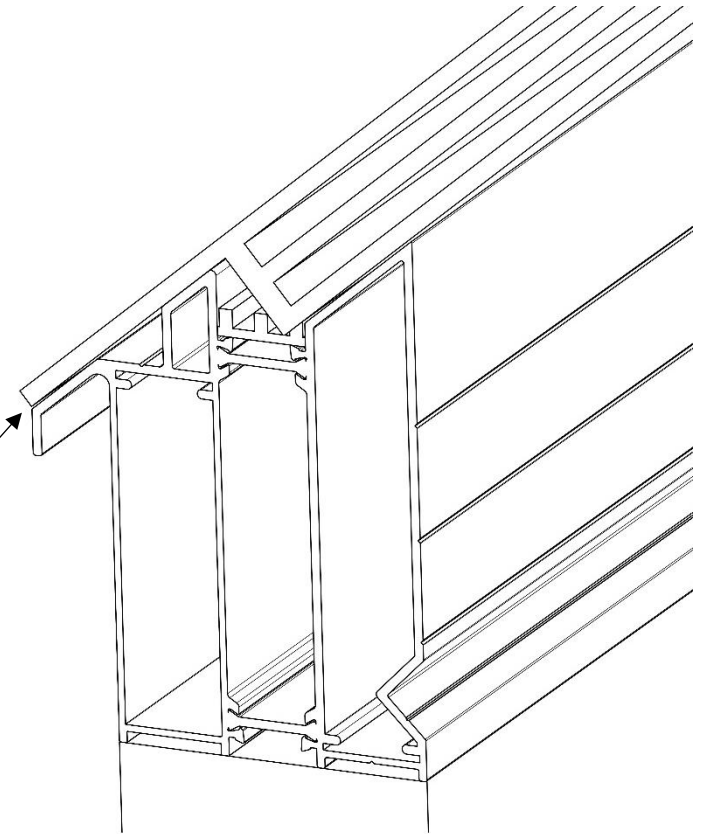

The assembly of your slimline® lantern is now complete. you are now ready to flash the upstand with your chosen roof membrane.

STEP 17.1 - FLASHING GUIDELINES - (SHEET MEMBRANE)

i) Ensure the roof membrane is tucked right under the dedicated drip lip that sits just under the glass. This is important as it acts as the final weathering stage to avoid water ingress in this area. Take a look at the diagram below which illustrates this detail. If using a torch on felt, we recommend that you cut your membrane to the correct size, fold back and pre-heat with your heat gun. Only then should you apply it to the side of the unit. This will prevent you from damaging the unit by applying heat directly.

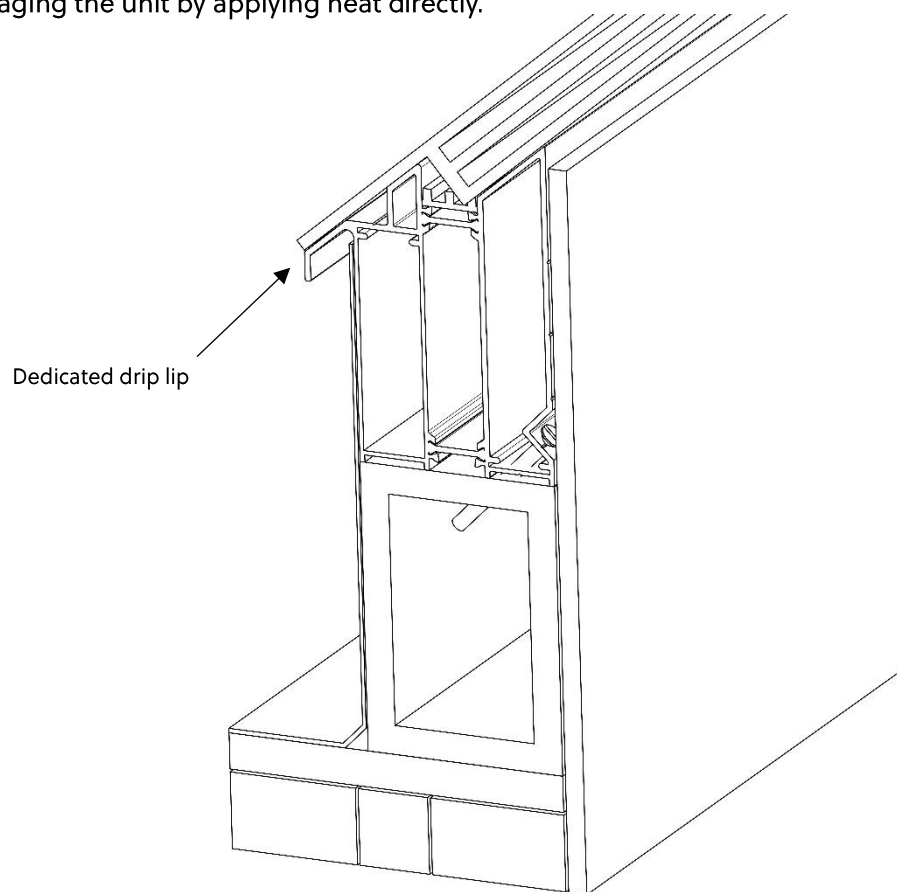

STEP 17.2 - FLASHING GUIDELINES - (GRP MEMBRANE)

i) If using GRP to finish the roof, you should silicone bond a 4mm plywood border around the upstand and kerb. Screw fix this into the timber kerb if you wish to make it more secure. This will provide a more suitable surface for the GRP to adhere to. Ensure that this goes right up underneath the drip lip as the below image shows. Also, ensure that the GRP layer is applied right up to and underneath the drip lip.

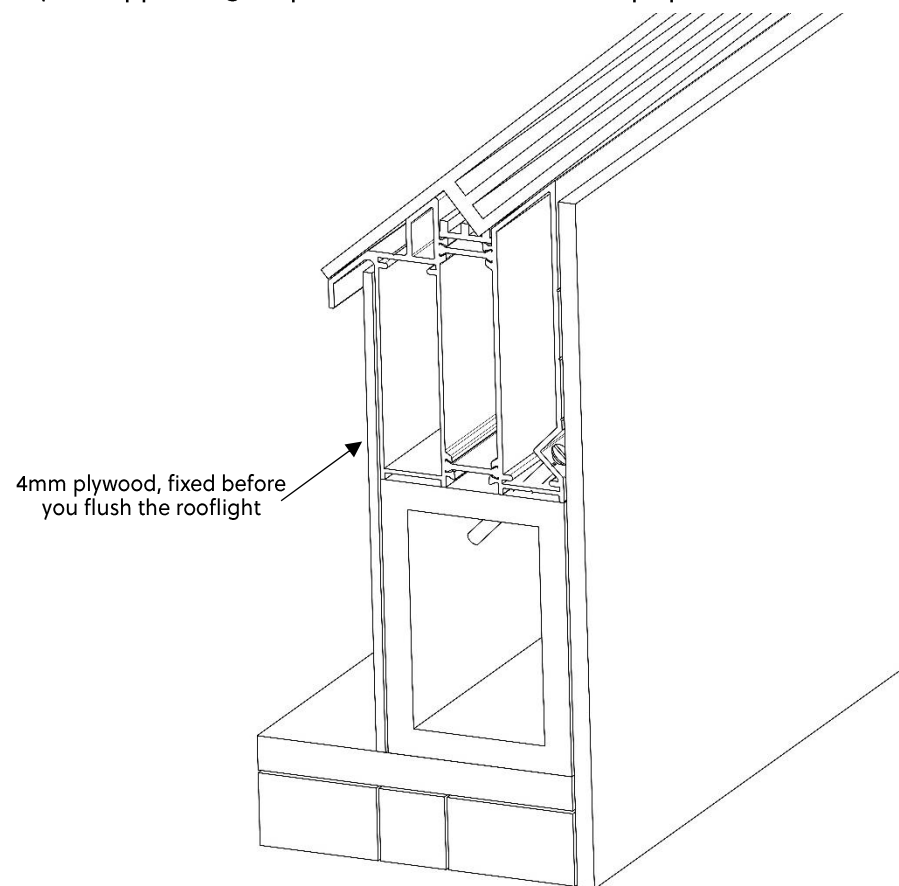

Your roof lantern assembly is now finished.

For internal plaster finishing details please refer to the roof cross-section fitting guide, located on page 20 of this guide.

ROOF CROSS SECTION FITTING GUIDE

The below cross section diagram illustrates how you need to finish your plastering, for units both with and without integrated blackout blinds.

