

ROOF MAKER

WORLD CLASS ROOFLIGHTS



PRODUCT SPECIFICATION & INSTALLATION GUIDE

FLAT PACKED PYRAMID ROOF LANTERN

DOUBLE GLAZED PYRAMID LANTERN
STANDARD PRODUCT SPECIFICATION

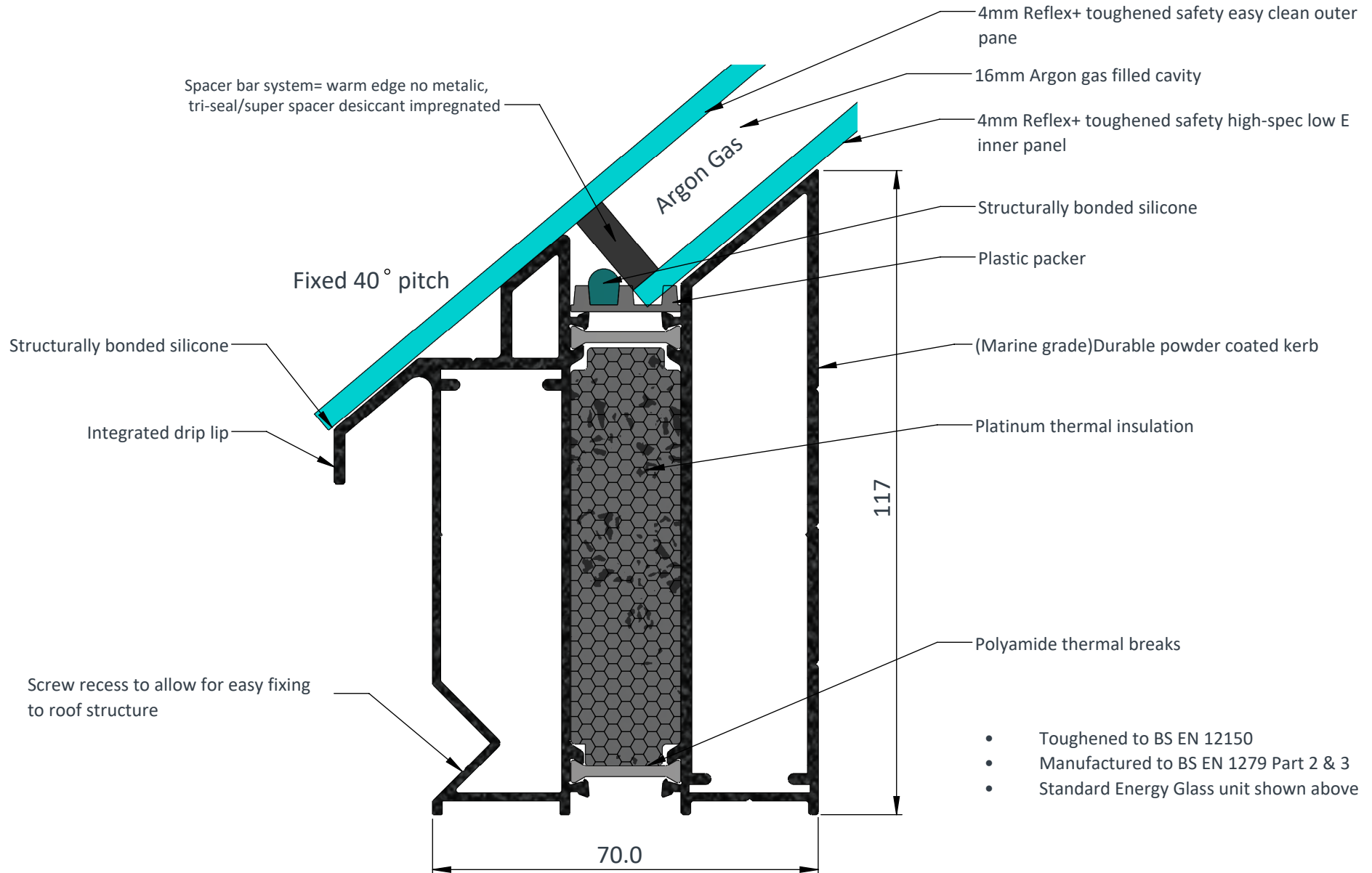

- Toughened to BS EN 12150
- Manufactured to BS EN 1279 Part 2 & 3
- Standard Energy Glass unit shown above

TRIPLE GLAZED PYRAMID LANTERN
STANDARD PRODUCT SPECIFICATION

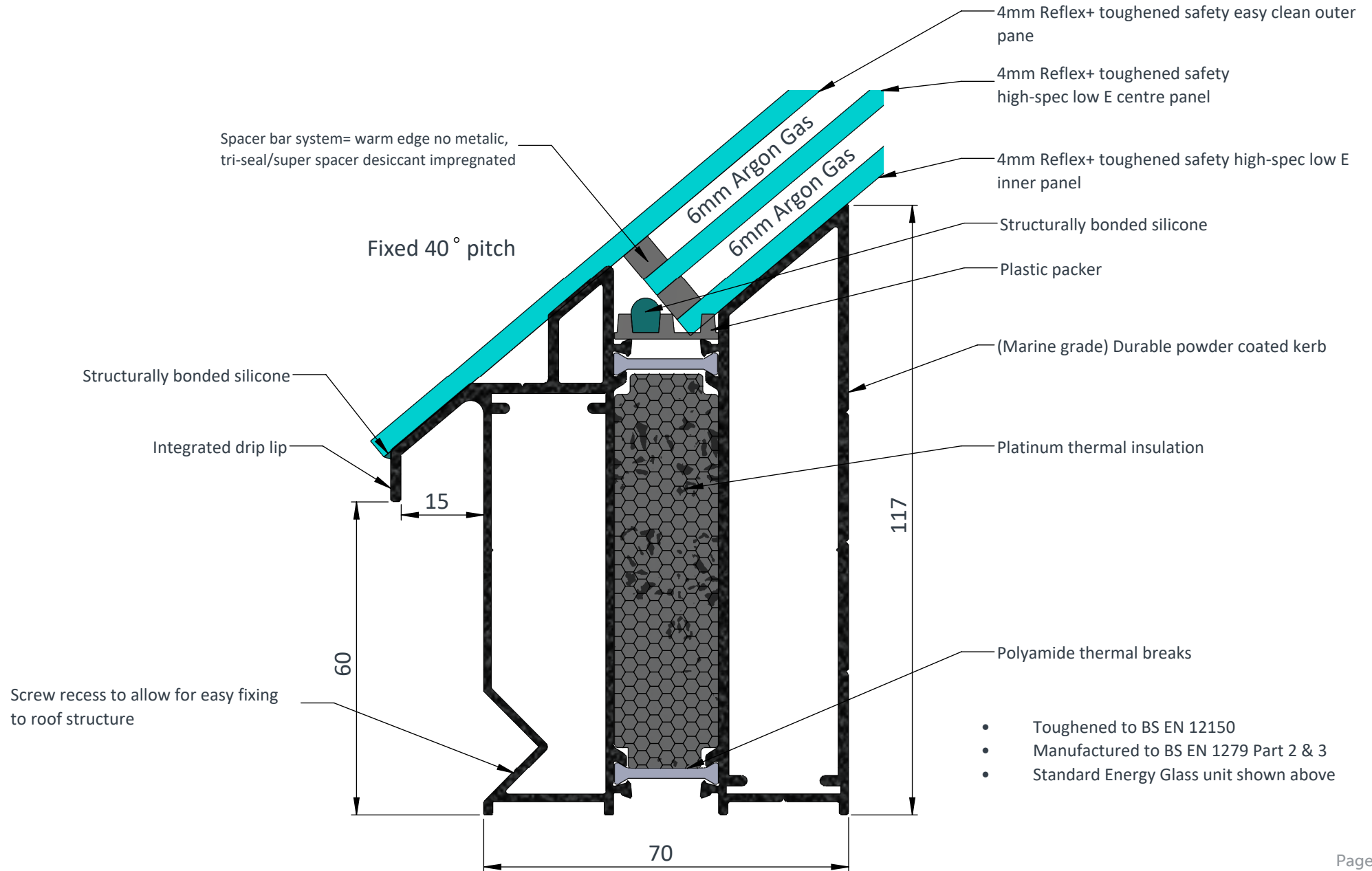

PYRAMID LANTERN STEP-BY-STEP INSTALLATION GUIDE

THANK YOU FOR CHOOSING ROOF MAKER, WE HOPE YOU ARE DELIGHTED WITH YOUR NEW ROOFLIGHT.

Our roof lanterns have been designed with speed and ease of construction in mind, so that you don't need to be a professional installer to build and fit them.

This guide will take you through an easy-to-follow process to ensure you build and install your roof lantern correctly, but if you do need advice or help, our technical support team are available to provide guidance.

PLEASE NOTE: For roof lanterns that feature blackout blinds, there is a blackout blind wiring guide available which we can provide, or is available to download in the technical section on our website. This also outlines the additional components that you will receive, such as the remote control and power pack.

GUIDE WEIGHTS FOR PYRAMID ROOF LANTERN

PYRAMID ROOF LANTERN		
Size (mm)	Double glazed Weight (KG)	Triple glazed Weight (KG)
400 x 400	16	18
700 x 700	32	40
1000 x 1000	55	70
1200 x 1200	73	95
1500 x 1500	105	140
1700 x 1700	130	174
2000 x 2000	172	233

THE GUIDE EXPLAINED

GUIDE A will cover the assembly of a Pyramid lantern with a standard '4 pane' configuration.

GUIDE B will cover the addition of a T-Bar, which is for larger units where the triangular panes of glass need to be split into 2 sections. This is specified for Pyramid roof lanterns that are triple glazed and measure between 1800mm x 1800mm and 2000mm x 2000mm. If this applies to your roof lantern, follow the instructions in **Guide A** up until the point which refers you to skip to **Guide B** for the remainder of your installation, should your lantern be split with additional glazing bars.

ROOF MAKER

WORLD CLASS ROOFLIGHTS

Call us: 0116 269 6297

Mon-Fri 9-5pm

WHAT DO I NEED TO CONSTRUCT MY ROOF LANTERN?

IN ADDITION TO YOUR PYRAMID ROOF LANTERN KIT, YOU WILL NEED:

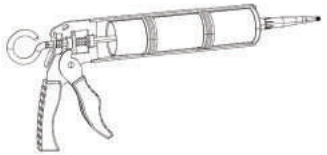

Silicone adhesive sealant (recommended Dow Corning 791 or similar)- Required for the fixation of your upstand to the prepared timber kerb. **Silicone required when glazing the unit will still be provided as part of your kit.**

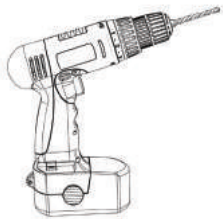

Drill with HSS drill bit – To pre-drill the aluminium upstand to form holes for your timber screws when fixing to your timber upstand.

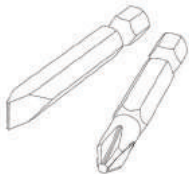

Posi drive and flathead drill bits – For fixing of screws and bolts throughout the assembly.



Timber screws – Measuring at least 50mm in length. Required to fix the upstand to the prepared timber kerb.

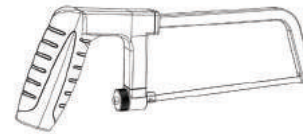

Hacksaw - To trim the plastic cap carriers as advised in the fitting guide.

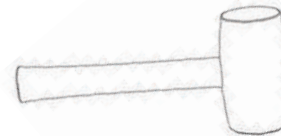

Rubber mallet – To carefully tap components into place such as carriers and cappings.

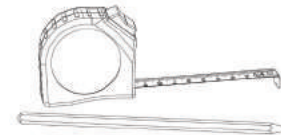

Tape measure and pencil

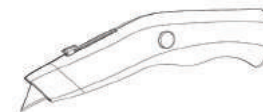

Stanley knife

Damp cloth – To wipe off any excess silicone as required.

ROOF MAKER

WORLD CLASS ROOFLIGHTS

Call us: 0116 269 6297

Mon-Fri 9-5pm















COMPONENT CHECKLIST

The images below show a component checklist that you will receive as part of your flat packed kit. This will be attached to the box which contains most of your components. Not all of the components listed will be applicable to your chosen specification. Your exact inventory will be outlined, along with quantities, as part of the list. This also includes imagery to help you locate the various components and familiarise yourself with what you will be working with.



Page 1 of 2

SUMILINLY LANTERN COMPONENT CHECKLIST			
JOB REF # NAME			
FRAME COLOUR			
NUMBER OF GLASS PANEES			
SIDE			
PACKED BY (print name)			
CHECKED BY (print name)			

COMPONENTS FOR STANDARD CONFIGURATION LANTERN (NO GLAZING SPLITS)			
IMAGE	COMPONENT	QTY	TICK
	Aluminum ridge body (with end blocks and fixings) - prepared with glazing tape		
	Pyramid apex hip attachment block (pyramid lanterns only)		
	Plastic ridge cap carrier		
	Aluminum ridge cap cover		
	Aluminum hip body - prepared with glazing tape		
	Plastic hip cap carrier		
	Aluminum hip cap cover		
	Pre-assembled upstand (prepared with nuts and bolts for hip body attachment)		
	Aluminum ridge end caps		
	Aluminum pyramid apex cap (pyramid lanterns only)		
	Plastic glazing spacers		
	Aluminum hip end caps		
	Black counter-sink screws		
	Allen key (in case adjustment of ridge is required)		
	Sealant tube		



Page 2 of 2

SUMILINLY LANTERN COMPONENT CHECKLIST			
JOB REF # NAME			

COMPONENTS FOR ADDITIONAL GLAZING SPLITS/VENT INSTALLATION (IF APPLICABLE)			
IMAGE	COMPONENT	QTY	TICK
	T-bar outer (longer than inner T-bar, with cut out) - prepared with glazing tape		
	T-bar inner - prepared with glazing tape		

COMPONENTS FOR LARGER LANTERN KITS (EXCEEDING 3000 X 1500 WITH UNASSEMBLED UPSTAND SECTIONS) (IF APPLICABLE)			
IMAGE	COMPONENT	QTY	TICK
	Upstand section (in lengths)		
	Nut and Bolt		
	Corner cleat type A		
	Corner cleat type B		
	Straight cleat (for large lanterns, joining upstand sections, end on end)		
	Self-drilling screws		

COMPONENTS FOR OPENING VENTS (IF APPLICABLE)			
IMAGE	COMPONENT	QTY	TICK
	Vent housing (includes winding mechanism or motor)		
	Pre-glazed vent lid		
	Chrome winding pole (for manual vents)		
	Rocker switch (if applicable)		
	Climate control (rain sensor unit, if applicable)		

Make sure to read through all steps and understand the requirements before beginning assembly.

Please take precaution when moving heavy objects and working at height - be sure to use suitable equipment.

GUIDE A
STANDARD 4 PANE CONFIGURATION

ROOF MAKER

WORLD CLASS ROOFLIGHTS

Call us: 0116 269 6297

Mon-Fri 9-5pm

STEP 1 - PREPARE THE TIMBER KERB

i) Before you begin the construction of your new roof lantern, you will have installed the timber kerb. The size of the internal opening should reflect the exact size of the roof lantern you have ordered. For example, the roof opening should measure exactly 2m x 2m for a unit that measures 2m x 2m.

Your timber kerb should measure 70mm in width, to match the width of the built-in upstand that you are going to assemble. We recommend a minimum height of 25mm from roof level, but this can be increased if required.

The upstand should be perfectly level and we also recommend that you check the corners have a 90° angle, by measuring it diagonally from corner to corner before installing the roof lantern.

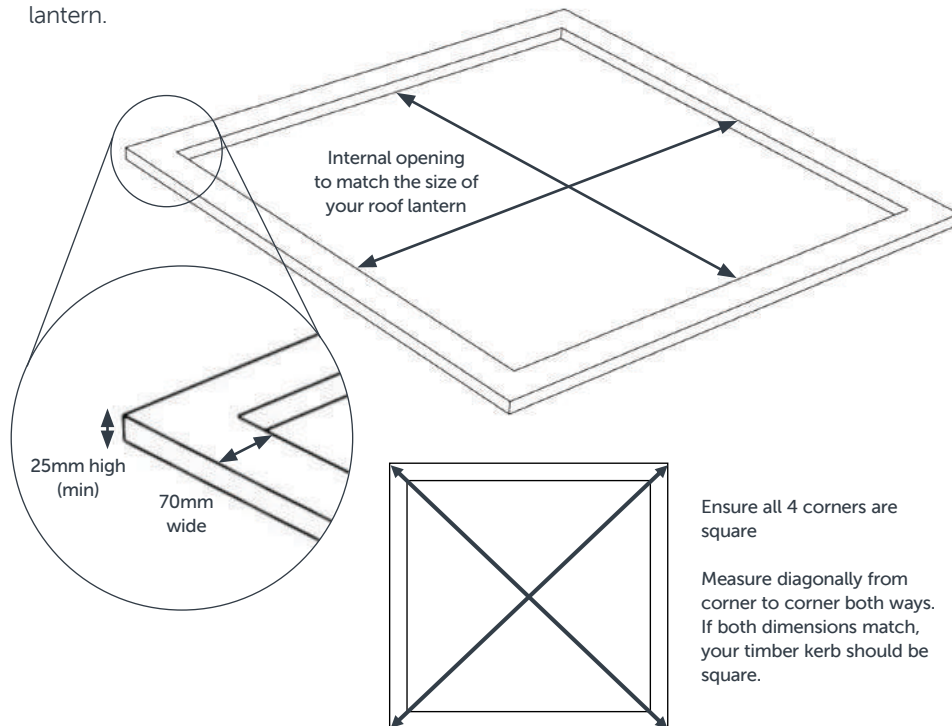

Internal opening to match the size of your roof lantern

25mm high (min)

70mm wide

Ensure all 4 corners are square

Measure diagonally from corner to corner both ways. If both dimensions match, your timber kerb should be square.

STEP 2 - PREPARE THE ROOF MEMBRANE

i) We recommend that you apply your roof membrane after installing your roof lantern, to avoid damaging or piercing it during the installation.

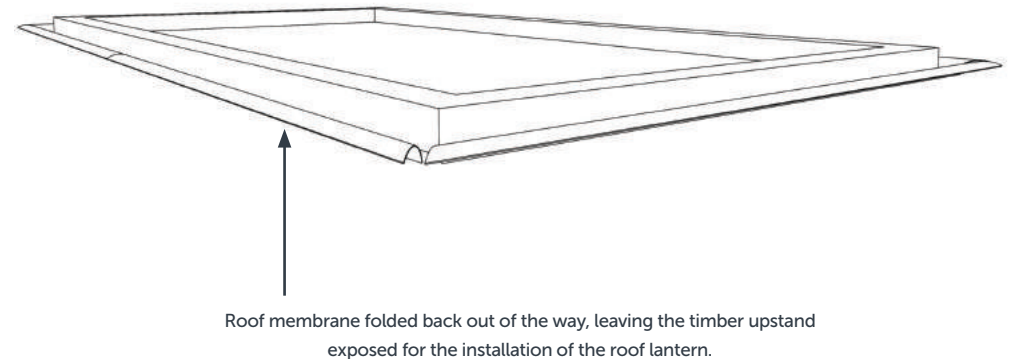

Roof membrane folded back out of the way, leaving the timber upstand exposed for the installation of the roof lantern.

You are now ready to begin the construction of your new roof lantern.

ROOF MAKER

WORLD CLASS ROOFLIGHTS

Call us: 0116 269 6297

Mon-Fri 9-5pm

STEP 3 - UPSTAND ASSEMBLY

For most sizes, the built-in, insulated upstand will come ready assembled. But if your roof lantern is larger than 1.5m x 1.5m you will need to assemble the frame yourself. **If your upstand is pre-assembled, proceed to step 4.**

i) Take two of the corner cleats and insert them into the slots in the frame as shown.

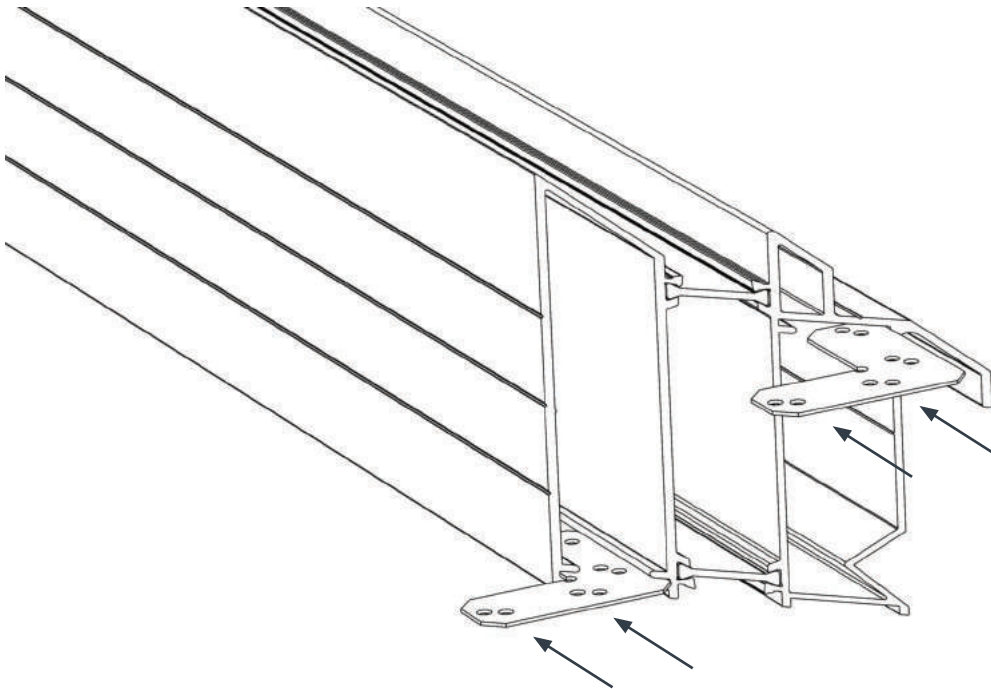

ii) Then take the other ends of the cleats and insert them into the slots of the corresponding piece of the frame. Before you push the two pieces of frame together, make sure that the nut and bolt are placed into the pre-cut hole as shown below.

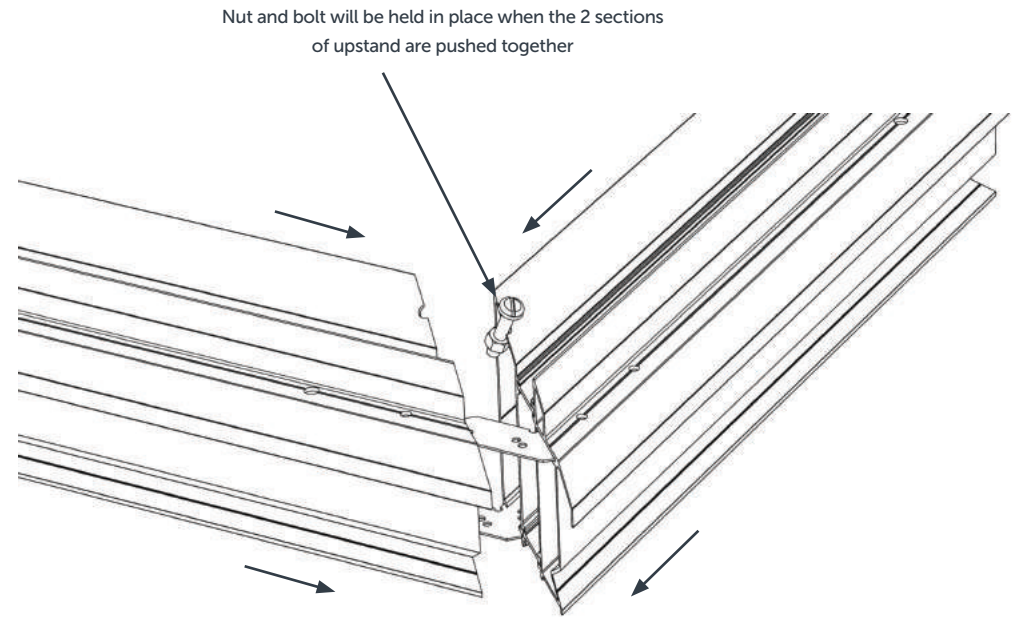

ROOF MAKER

WORLD CLASS ROOFLIGHTS

Call us: 0116 269 6297

Mon-Fri 9-5pm

STEP 3 - UPSTAND ASSEMBLY - CONTINUED

iii) Next fasten the frame section together securely using the screws provided through the top of the upstand, through the 4 pre-formed holes. Repeat for all corners.

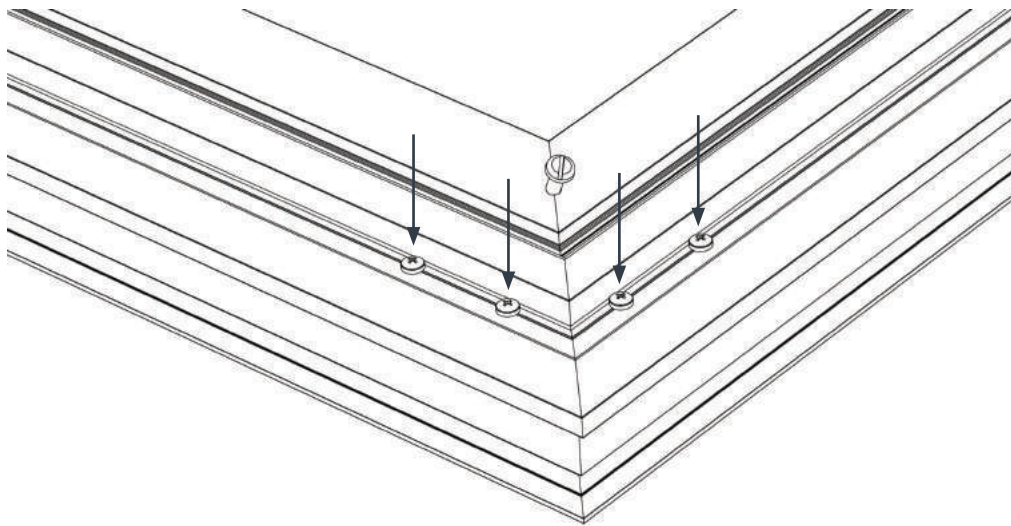

iv) Turn the upstand over and repeat the same process for each corner on the underside of the unit. Fixing the screws through each pre-formed hole. Once complete, the frame should be securely fastened together.

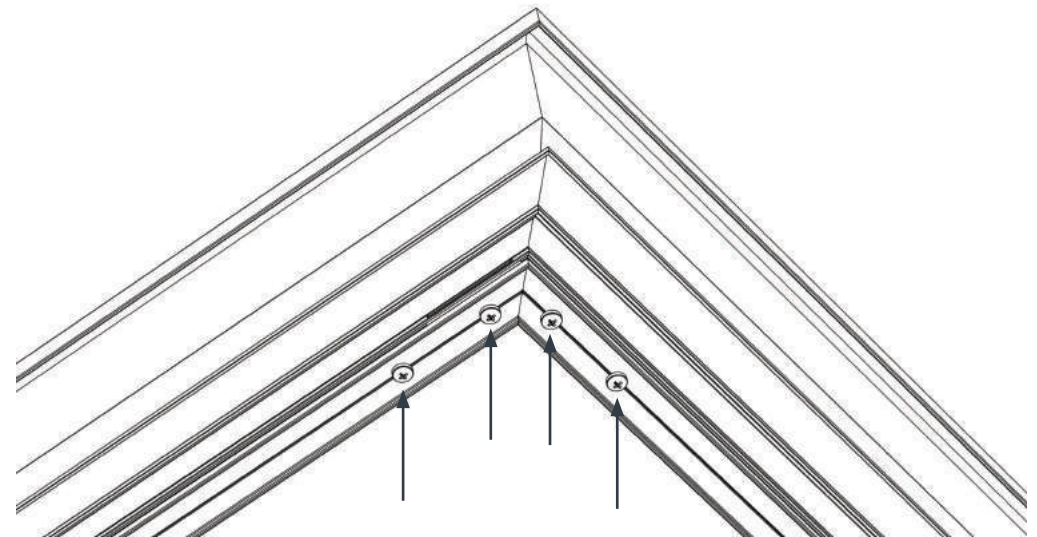

ROOF MAKER

WORLD CLASS ROOFLIGHTS

Call us: 0116 269 6297

Mon-Fri 9-5pm

STEP 4 - FIXING YOUR UPSTAND TO THE TIMBER KERB

i) Apply a thick bead of silicone all the way around the timber kerb about 20mm from the internal edge. Only use a professional quality silicone adhesive sealant such as Dow Corning 791.

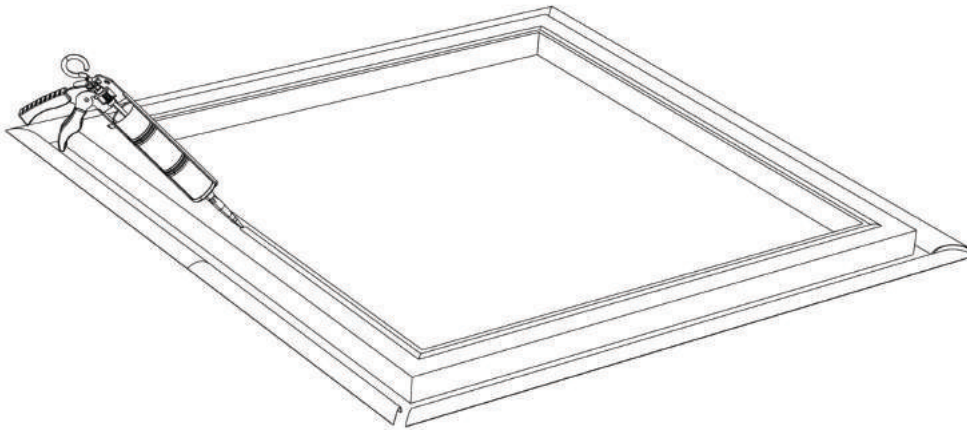

ii) Then carefully place the assembled upstand on to the kerb, ensuring it sits flush with the inner and outer edge of the kerb.

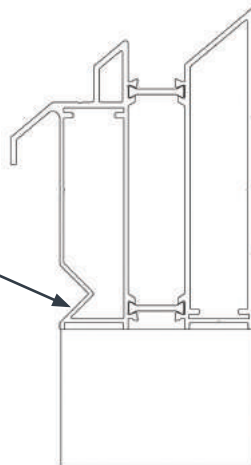

(Section view of your timber kerb with upstand section sitting flush on both sides)

Purpose made groove here to screw-fix the upstand section to your timber kerb (next step)

iii) You now need to secure the upstand to the timber kerb by inserting screws into the purpose made groove as shown, about 100mm from each corner, screwing through the upstand into the timber underneath. You will need to predrill your holes into the aluminium frame using a standard metal drill bit.

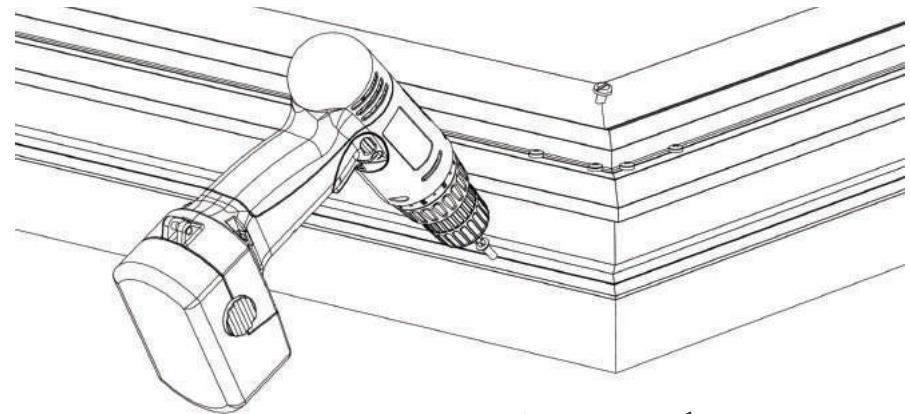

We recommend a minimum of 12 screws - two at each corner, with a further screw in the middle of each side.

For larger lanterns, we recommend inserting additional screws at approx. 500mm intervals.

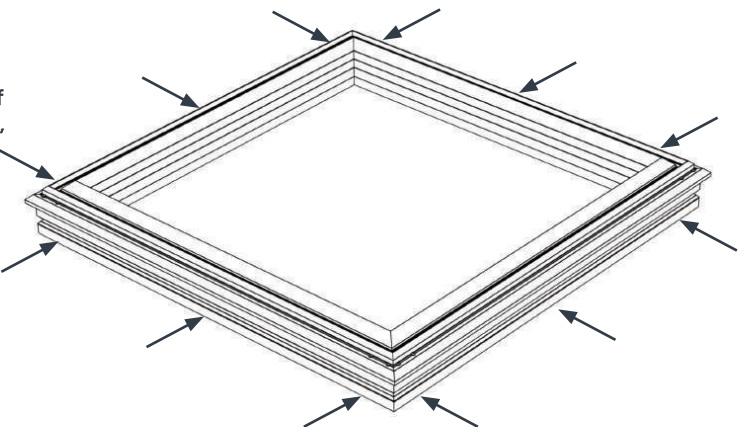

You are now ready to attach the 4 provided hip bodies to the upstand .

ROOF MAKER

WORLD CLASS ROOFLIGHTS

Call us: 0116 269 6297

Mon-Fri 9-5pm

STEP 5 - FIXING THE HIP BODIES

- i) Bring the hip bar into position over the upstand and slide the head of the bolt into the slot of the hip bar. Please note that the end of the hip bars that have angled corners need to be positioned at the top of the lantern.

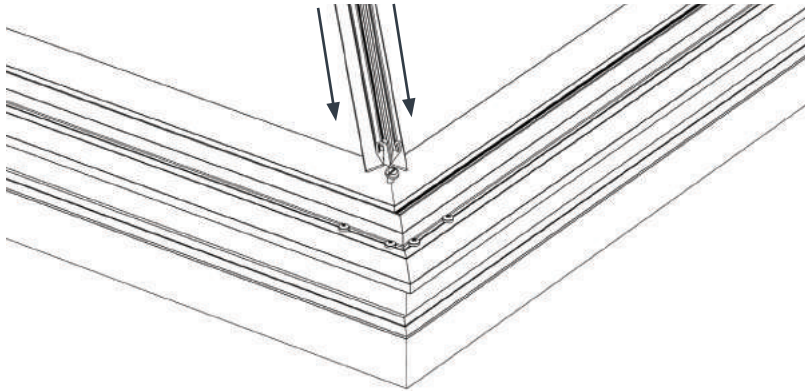

- ii) Now pull the hip body toward you whilst tightening the bolt. This will ensure that the internal nut stays in place whilst tightening. Repeat for all 4 corners

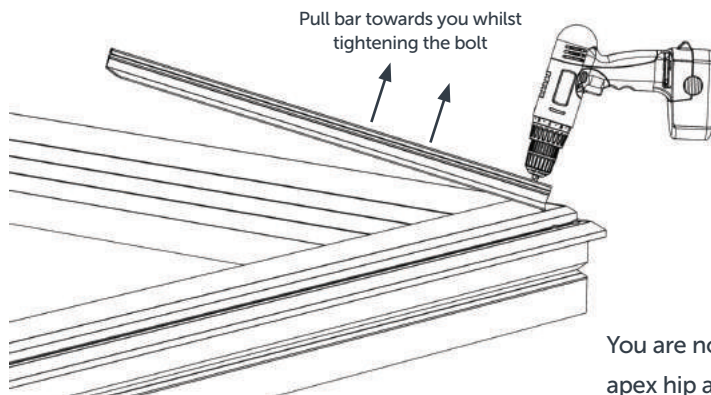

You are now ready to introduce your apex hip attachment block.

STEP 6 - FIXING YOUR HIP BARS TO THE APEX BLOCK

- i) The apex block already houses the bolts that will connect to your hip bars. Slide the slotted end of the hip bars over the bolts in the apex block. Position the hip bars so they connect with each other in line on all 4 sides as shown. Tighten the bolts.

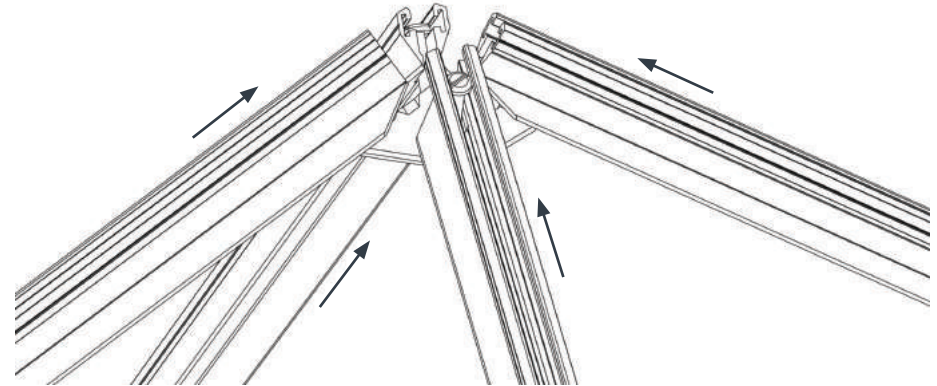

Ensure that the angled cut outs on your hip bars line up perfectly on all 4 sides as shown here. You can then tighten all 4 bolts to brace the 4 bars together

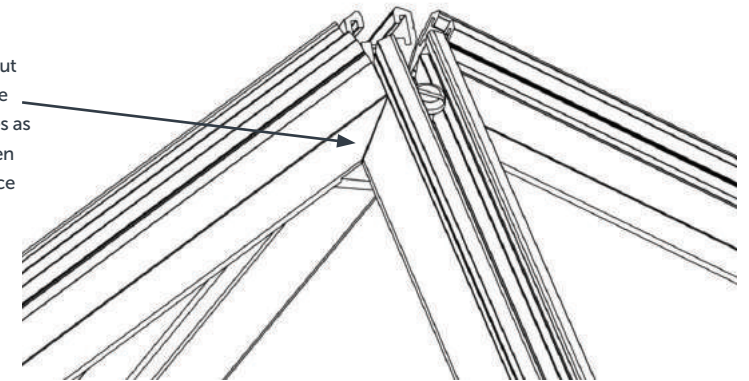

- ii) Now remove the blue protective film from each side of the ridge and hip profiles.

IF YOUR LANTERN IS TRIPLE GLAZED & MEASURES
BETWEEN 1800mm x 1800mm – 2000mm x 2000mm,
SKIP AHEAD TO GUIDE B ON PAGE 18
FOR THE REMAINDER OF THE INSTALLATION

ROOF MAKER

WORLD CLASS ROOFLIGHTS

Call us: 0116 269 6297

Mon-Fri 9-5pm

STEP 7 - POSITIONING YOUR GLAZING PACKERS

- i) Fit the packers at each corner of the upstand, and apply a small spot of silicon either side of the packer which will stop them from sliding from side to side.

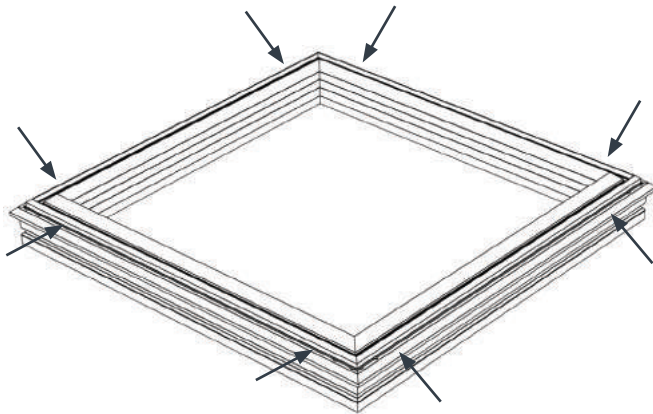
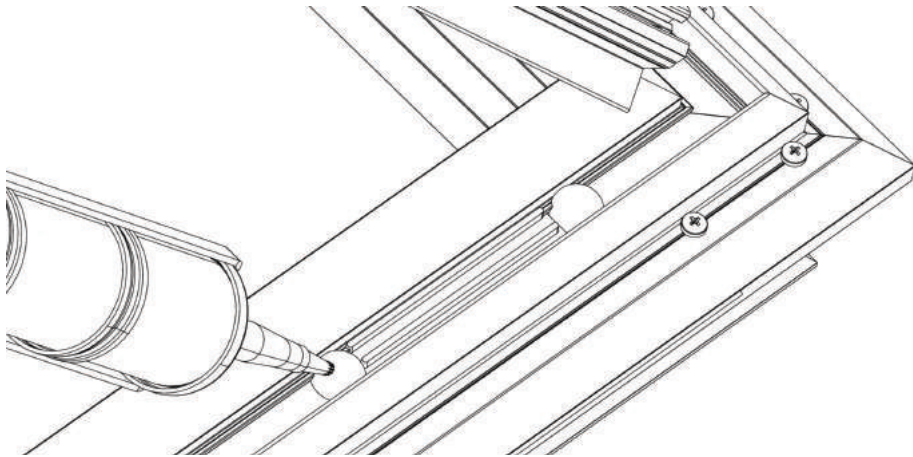

The next stage is to insert the glass sections. The frame is designed so these will fit easily and neatly into place, but care needs to be taken as these are the heaviest components of your roof lantern.

STEP 8 - PEELING BACK THE PROTECTIVE FILM

- i) Before you introduce the glass panels to the unit, peel back the first approx. 5cm of the green protective film from the glazing tape that has been pre-applied to your ridge and hip bars. Do this at both ends of the hips and ridge bar as shown. Ensure that this excess film will be accessible from the inside of the roof lantern when the glass is positioned.

Fold the protective film from the tape underneath the hip bars so it can be reached from the inside of the lantern at the final stages

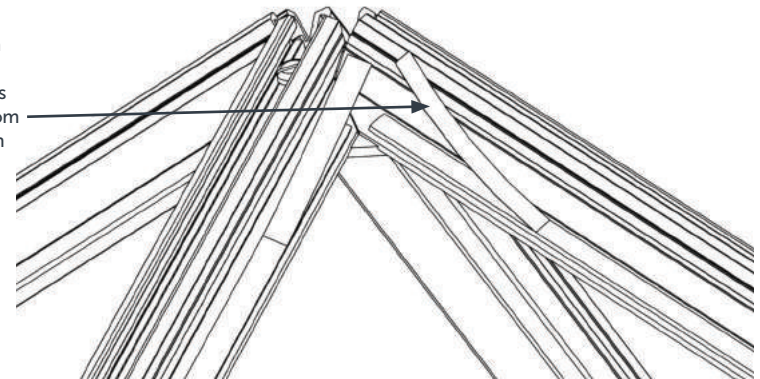

Repeat this at both ends and on either side of all 4 bars, as the arrows indicate

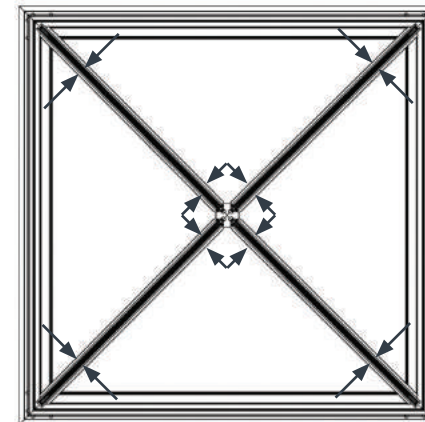

ROOF MAKER

WORLD CLASS ROOFLIGHTS

Call us: 0116 269 6297

Mon-Fri 9-5pm

STEP 9 - INSERTING THE GLASS PANELS

- i) Bring in one of the panels and sit it on the inside groove of the packers, and then gently lower it into the frame. Repeat this with all 4 panels.

Ensure that you insert the glass in to the inside groove of the packer to ensure that the glass sits flush onto the frame. Failure to do this will effect the fitting of your glazing bar cappings later in the installation

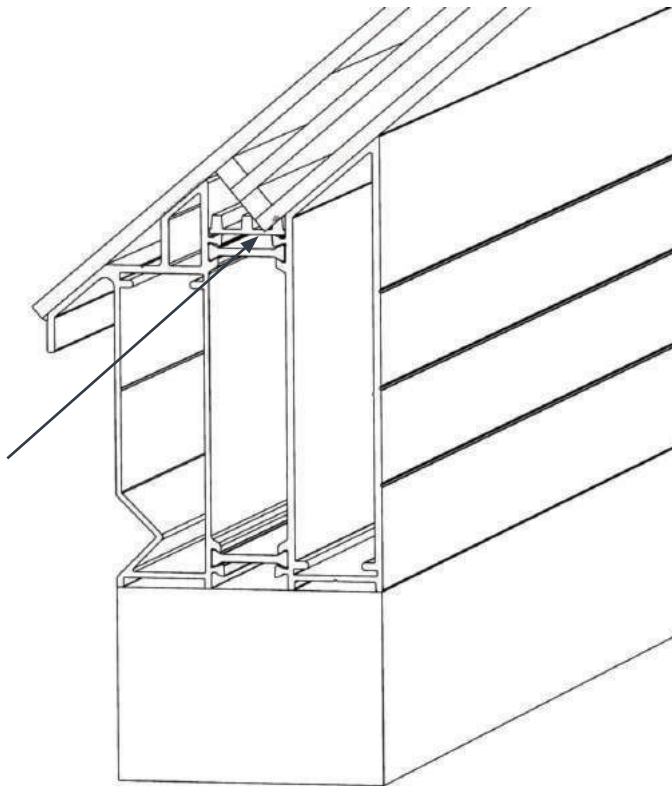

When you are confident that the glass is positioned correctly, you are ready to apply silicone as per the next step.

STEP 10 - APPLYING SILICONE

- i) Apply a generous amount of silicone into the groove at the top, and bottom of each of the hip profiles, running about 100mm from each end of the hip bars, top and bottom.

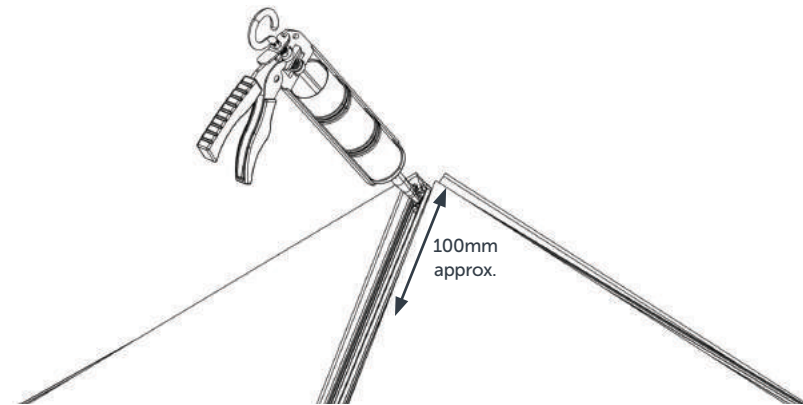

- ii) Next run silicone between all the glass panels and frames, on either side of the hip bars, again running approximately 100mm of silicone from each end of the hip bars, top and bottom.

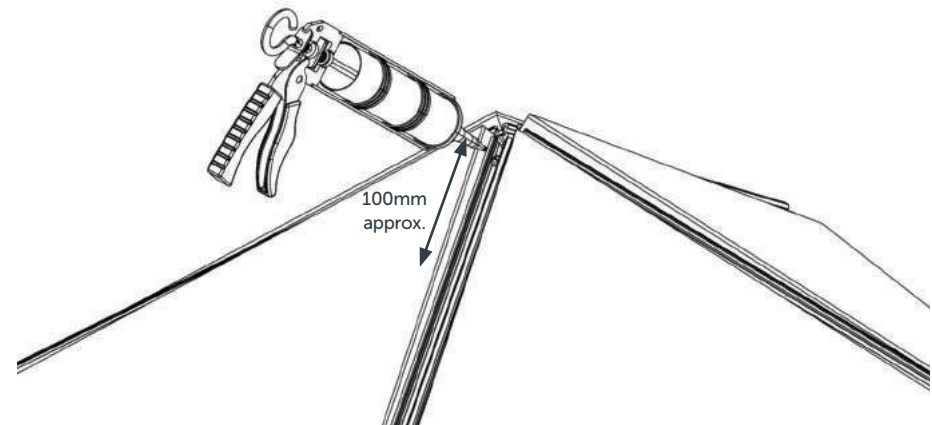

ROOF MAKER

WORLD CLASS ROOFLIGHTS

Call us: 0116 269 6297

Mon-Fri 9-5pm

STEP 11 - INTRODUCING THE HIP CARRIERS AND HIP TOP CAPS

i) Prepare your hip carriers and aluminium top caps by sliding them together with the angled parts of both pieces being positioned at the same end. These pieces are angled where they will meet at the apex when applied. Stagger the hip carrier so 100mm is sticking out at the top.

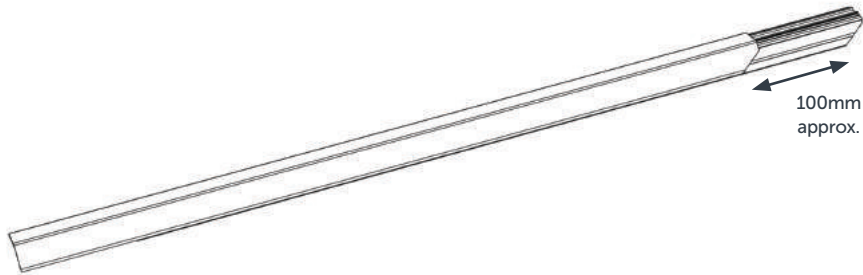

ii) Gently tap the hip carriers and top caps onto the hip bars with your rubber mallet.

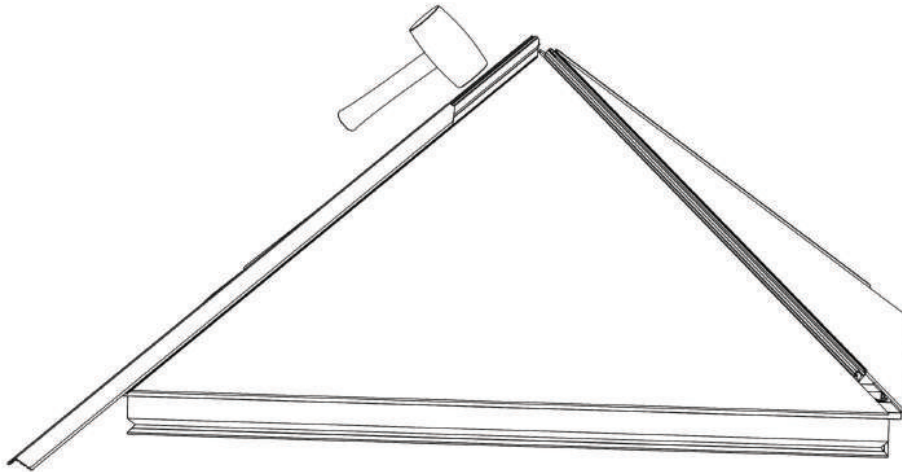

Repeat for all 4 bars.

iii) Slide the hip carriers up the hip bar, ensuring that the angled cut-outs line up perfectly.

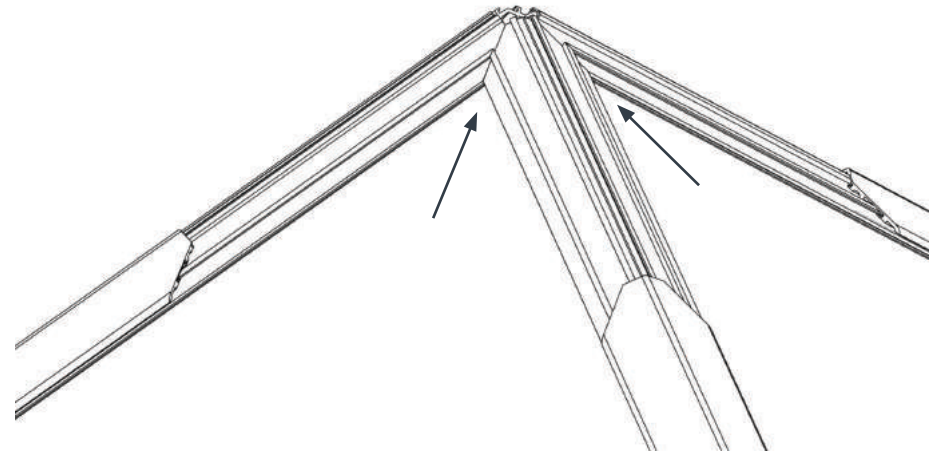

iv) Following this, slide your Hip top caps up into place using the same principal, lining them up equally at the top as shown.

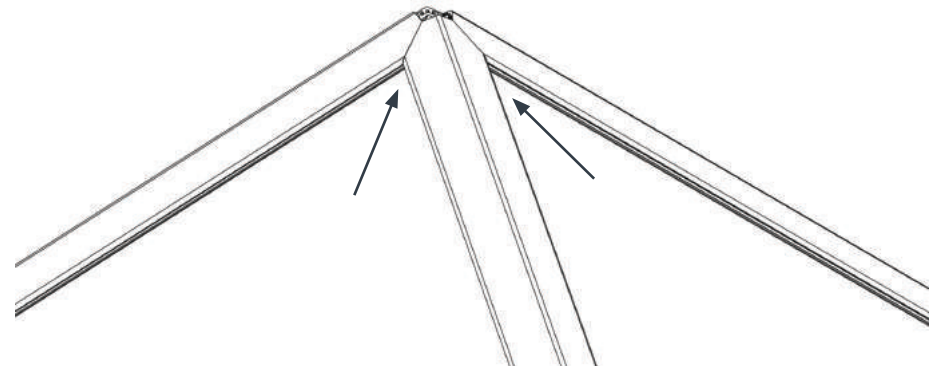

ROOF MAKER

WORLD CLASS ROOFLIGHTS

Call us: 0116 269 6297

Mon-Fri 9-5pm

STEP 12 - FITTING THE HIP CAPS

- i) If the plastic hip carrier is protruding from the bottom of the hip bars, use a hacksaw to carefully remove the excess, being careful not to damage the aluminium hip caps. Repeat at each corner if necessary.

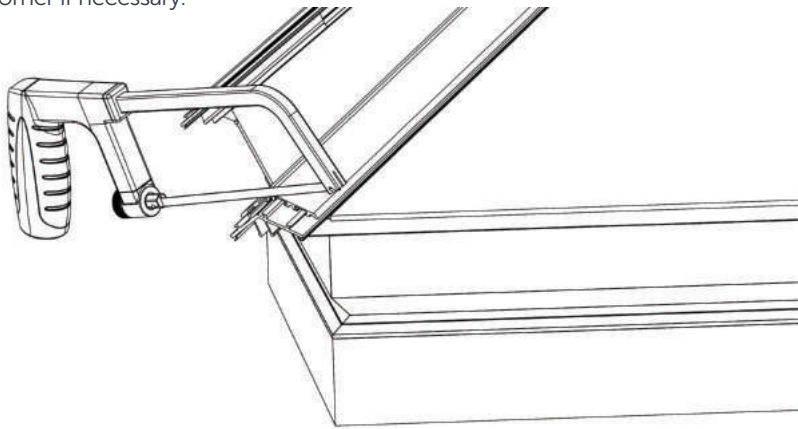

- ii) Using a screw gun set at a low gear, attach the hip end caps as shown, being careful not to overtighten them. Repeat at all 4 corners of the lantern.

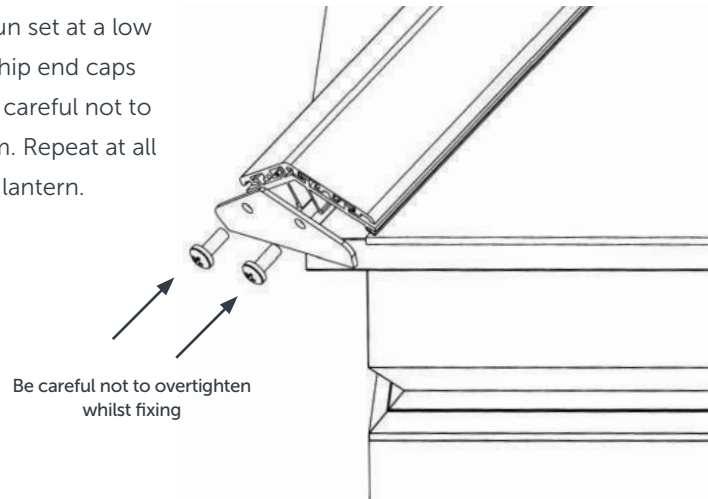

STEP 13 - ATTACHING THE APEX CAP

- i) It is now time to fit the Apex cap. Fill the space in the apex, above the hip caps generously with silicone as shown and apply the apex cap.

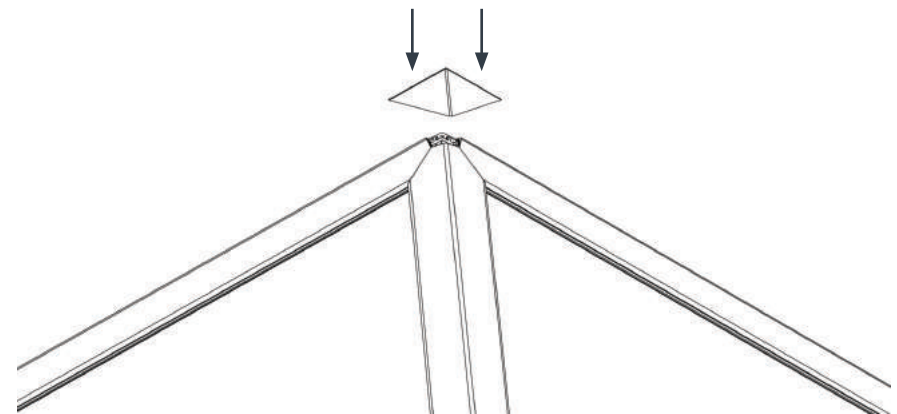
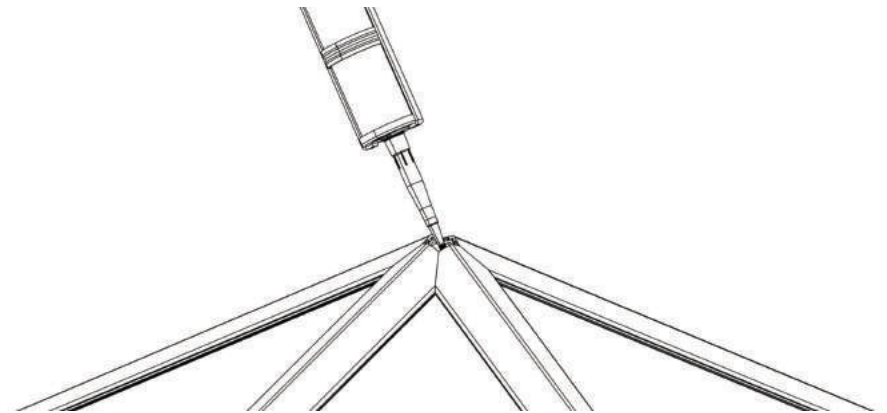

Ensure that the cap goes on neatly and level, wiping away any excess silicone with a damp cloth

STEP 14 - FINAL STAGE OF ASSEMBLY – SEALING THE UNDERSIDE OF THE GLASS PANELS

i) Your Pyramid Roof Lantern is now nearly complete. All that remains, is to seal the underside of the bottom edge of the glass with silicone. Repeat this on all 4 sides.

The assembly of your Pyramid roof lantern is now complete! You are now ready to flash the upstand with your chosen roof membrane.

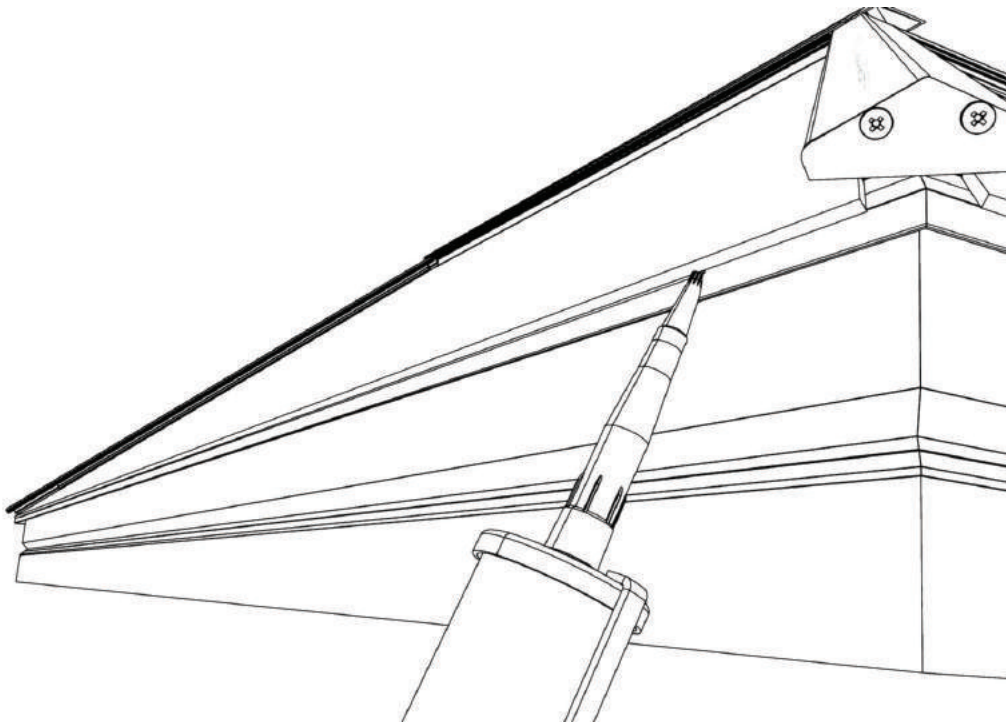

i) From the inside of the lantern, gently remove all of the protective film from the glazing tape on the hip bars.

ROOF MAKER

WORLD CLASS ROOFLIGHTS

Call us: 0116 269 6297

Mon-Fri 9-5pm

STEP 15.1 - FLASHING GUIDELINES - (sheet membrane)

i) Ensure the roof membrane is tucked right under the dedicated drip lip that sits just under the glass. This is important as it acts as the final weathering stage to avoid water ingress in this area. Take a look at the diagram below which illustrates this detail. If using a torch on felt, we recommend that you cut your membrane to the correct size, fold back and pre-heat with your heat gun. Only then should you apply it to the side of the unit. This will prevent you from damaging the unit by applying heat directly.

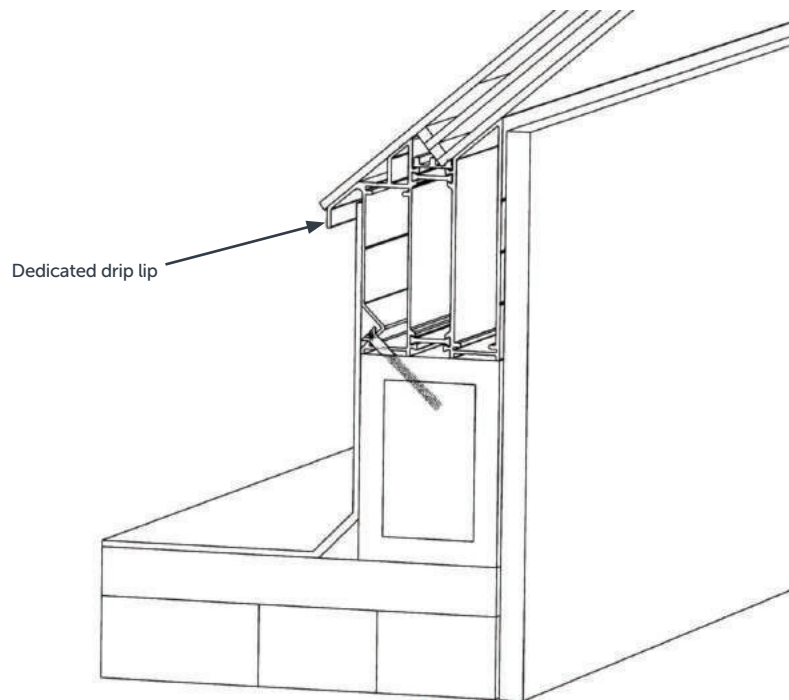

STEP 15.2 - FLASHING GUIDELINES - (GRP membrane)

i) If using GRP to finish the roof, you should silicone bond a 4mm plywood border around the upstand and kerb. Screw fix this into the timber kerb if you wish to make it more secure. This will provide a more suitable surface for the GRP to adhere to. Ensure that this goes right up underneath the drip lip as the below image shows. Also, ensure that the GRP layer is applied right up to and underneath the drip lip.

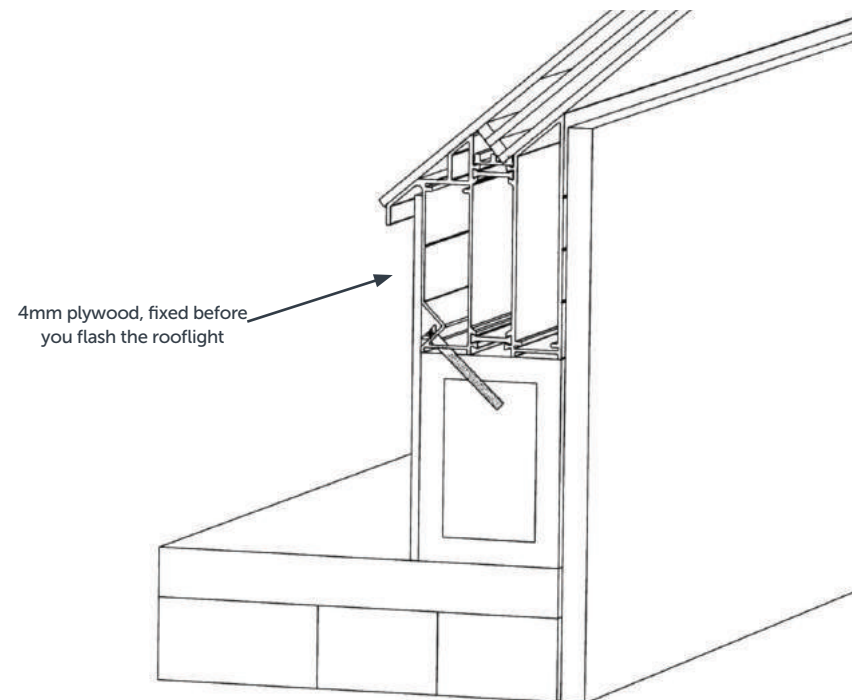

Your roof lantern assembly is now finished. For internal plaster finishing details please refer to the cross-section fitting guide, located on page 28 of this guide.

GUIDE B

FOR LARGER PYRAMID LANTERNS WHICH REQUIRE ADDITIONAL SPLITS IN THE GLAZING

This follows on from step 6 in the guide where you are ready to position your glazing packers

STEP 7 - POSITIONING YOUR GLAZING PACKERS

i) Fit the packers at each corner of the upstand, and apply a small spot of silicone either side of the packer which will stop them from sliding from side to side.

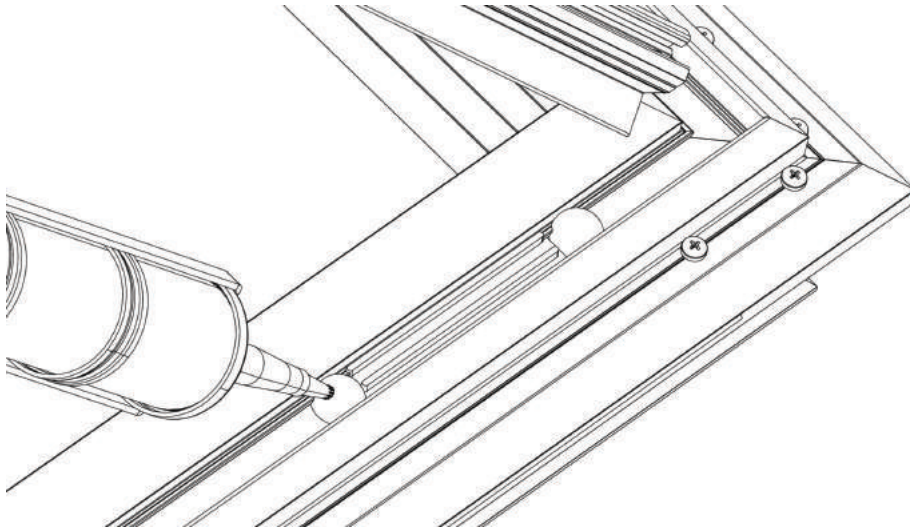

ii) You will require 2 packers per pane of glass (16 total). These will be provided as part of your kit. Position these as per the image below, remembering to put a spot of silicone on either side to prevent them sliding when you position the glass.

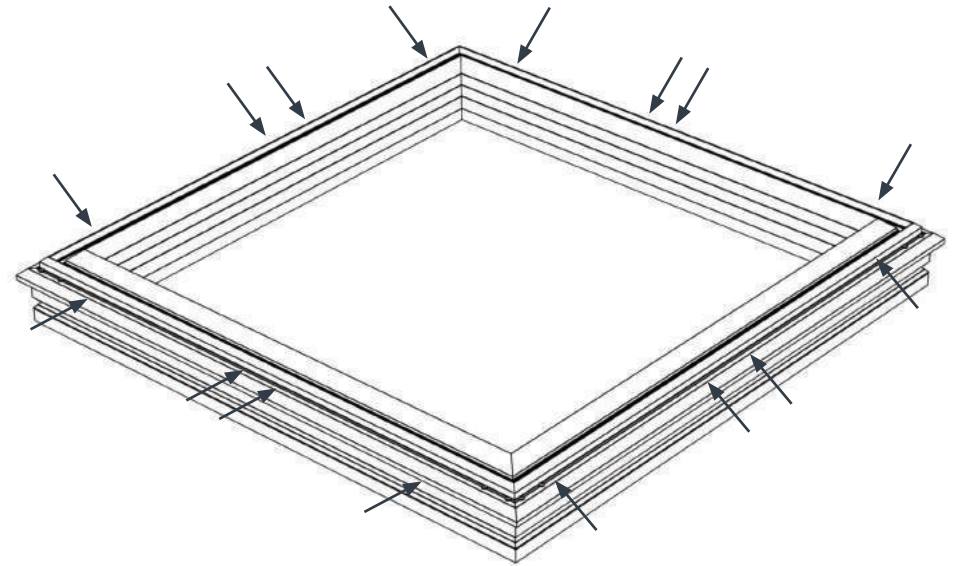

The next stage is to insert the glass sections. The frame is designed so these will fit easily and neatly into place, but care needs to be taken as these are the heaviest components of your roof lantern.

ROOF MAKER

WORLD CLASS ROOFLIGHTS

Call us: 0116 269 6297

Mon-Fri 9-5pm

STEP 8 - PEELING BACK THE PROTECTIVE FILM

- i) Before you introduce the glass panels to the unit, peel back the first approx. 5cm of the green protective film from the glazing tape that has been pre-applied to your ridge and hip bars. Do this at both ends of the hips and ridge bar as shown. Ensure that this excess film will be accessible from the inside of the roof lantern when the glass is positioned.

Fold the protective film from the tape underneath the hip bars so it can be reached from the inside of the lantern at the final stages

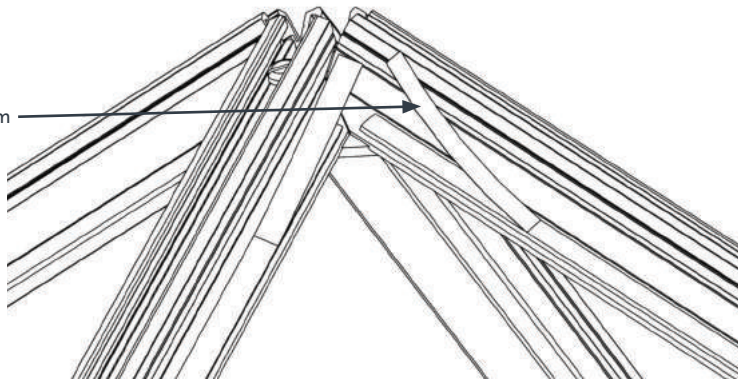

Repeat this at both ends and on either side of all 4 bars, as the arrows indicate

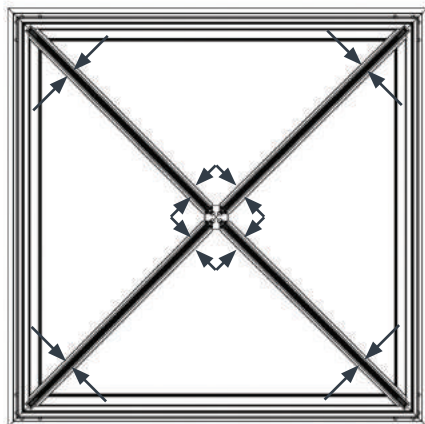

STEP 9 - INTRODUCE THE FIRST PANEL OF GLASS INTO THE LANTERN

- i) Position the glass, sitting it into the inside groove of the packers, making sure it is pushed up against the hip bar on the same side as much as possible.

Ensure that you insert the glass in to the inside groove of the packer to ensure that the glass sits flush onto the frame. Failure to do this will effect the fitting of your glazing bar cappings later in the installation

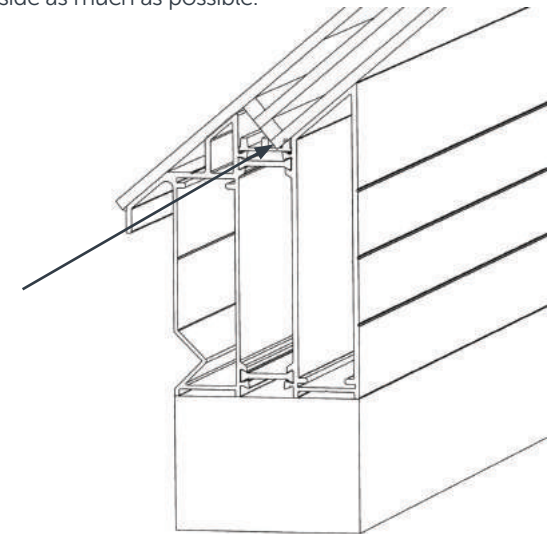

Ensure that the glass is pushed up against the hip bar as much as possible

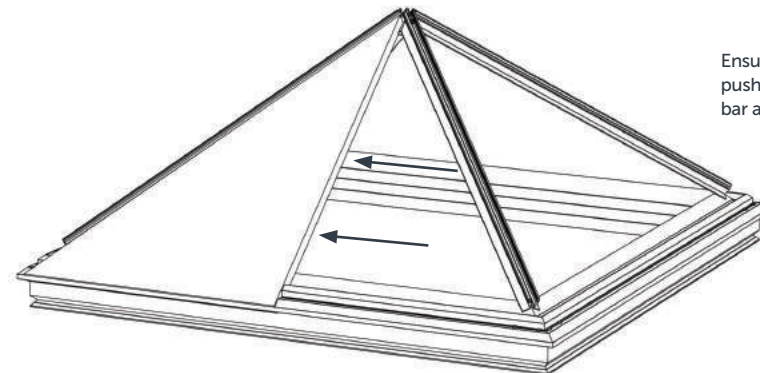

You are now ready to prepare the inside T-bar.

ROOF MAKER

WORLD CLASS ROOFLIGHTS

Call us: 0116 269 6297

Mon-Fri 9-5pm

STEP 10 - PREPARING THE INSIDE SPLIT BAR OR T-BAR

- i) You will have a 8 T-Bars in total, in 2 different sizes. The 2 shorter T-Bars are what you require at this stage.
- ii) The T-bars will be readily prepared with glazing tape, on both sides of the central spine. Before positioning the T-bar, ensure that approximately 5cm of the green protective film has been peeled back from both sides of the spine. Fold this excess film around the back of the bar, so it can be reached from the inside of the lantern when the construction is complete.

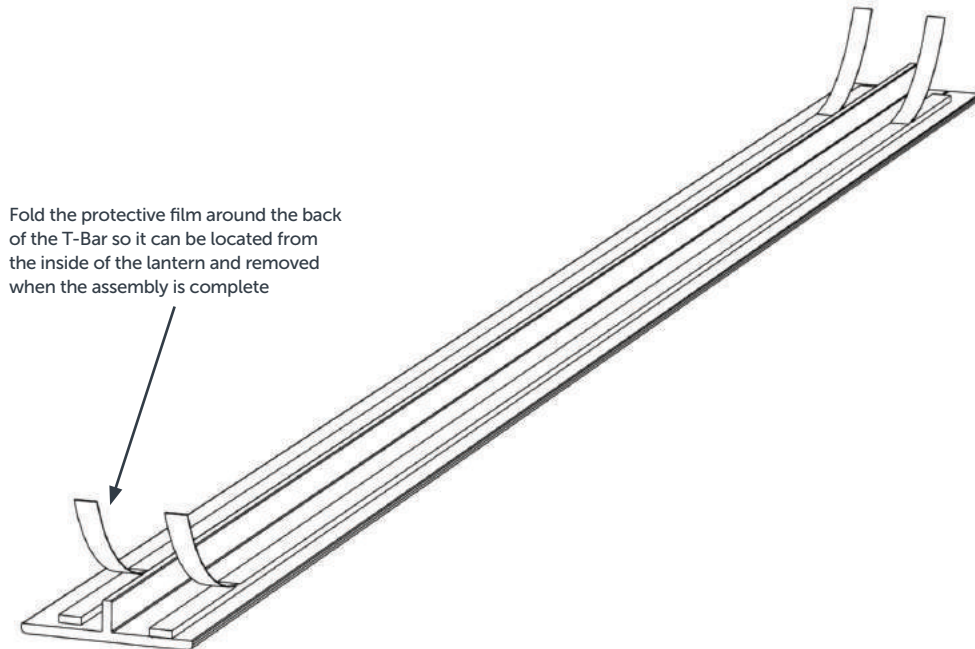

You are now ready to position your T-Bar

STEP 11 - INTRODUCING THE INSIDE SPLIT BAR OR T-BAR

- i) The end of the inner T-bar that has an angular cut will be positioned at the top or apex of the unit. Gently pull the top of the set glass panel toward you and carefully set the T-Bar behind the glass panel as shown. Ensure that the glass rests on the T-Bar all the way down the unit but doesn't touch the central spine of the T-bar. The bottom of the T-bar will rest on the angled face of the upstand at the bottom.

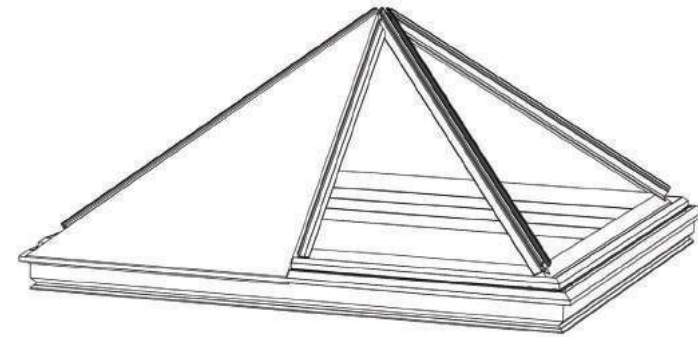

- ii) You are now ready to drop in the next panel of glass onto the inside groove of the packers, gently positioning the glass into the frame. Lastly, ensure the T-Bar is positioned exactly in the centre between the 2 panels of glass.

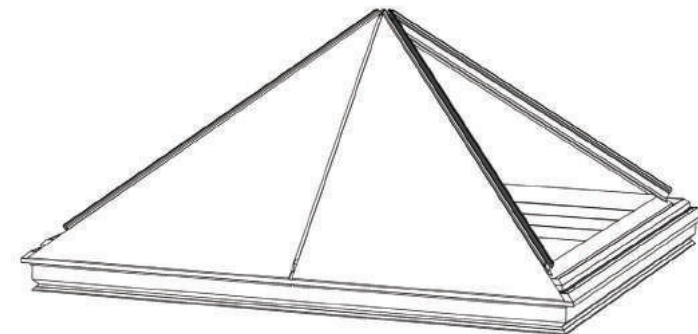

Repeat this process on all 4 sides of your lantern

ROOF MAKER

WORLD CLASS ROOFLIGHTS

Call us: 0116 269 6297

Mon-Fri 9-5pm

STEP 12 - APPLYING SILICONE

- i) Apply a generous amount of silicone into the groove at the top, and bottom of each of the hip profiles, running about 100mm from each end of the hip bars, top and bottom.

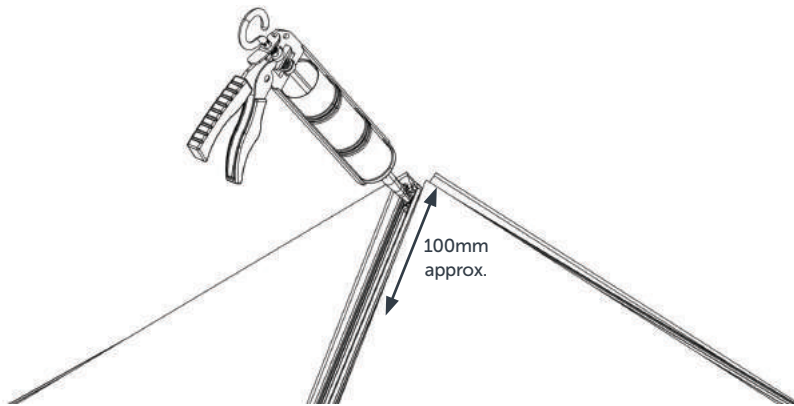

- ii) Next run silicone between all the glass panels and frames, on either side of the hip bars, again running approximately 100mm of silicone from each end of the hip bars, top and bottom.

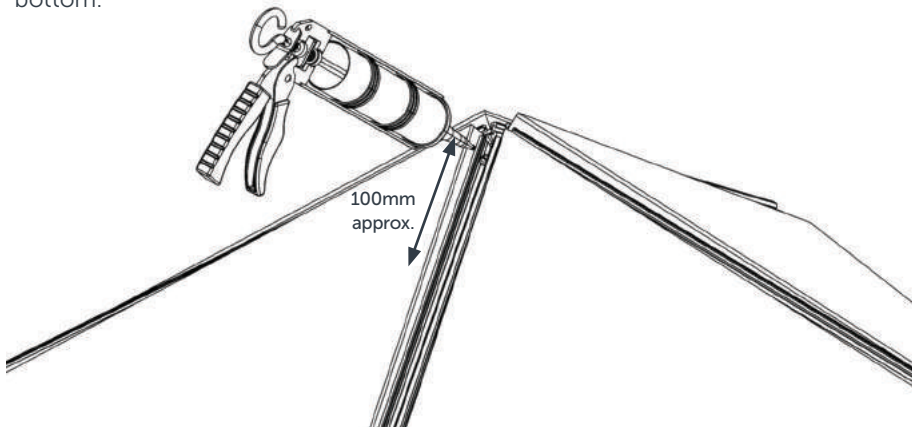

STEP 13 - INTRODUCING THE HIP CARRIERS AND HIP TOP CAPS

- i) Prepare your hip carriers and aluminium top caps by sliding them together with the angled parts of both pieces being positioned at the same end. These pieces are angled where they will meet at the apex when applied. Stagger the hip carrier so 100mm is sticking out at the top.

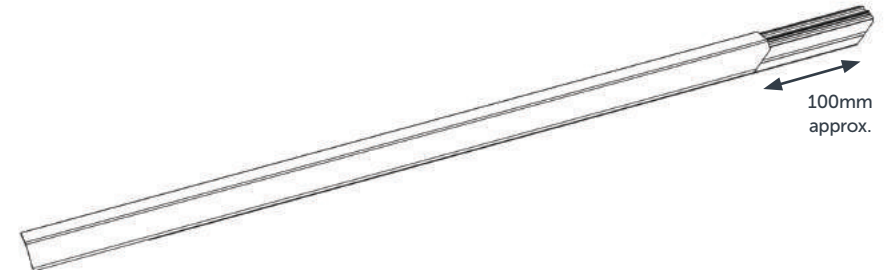

- ii) Gently tap the hip carriers and top caps onto the hip bars with your rubber mallet.

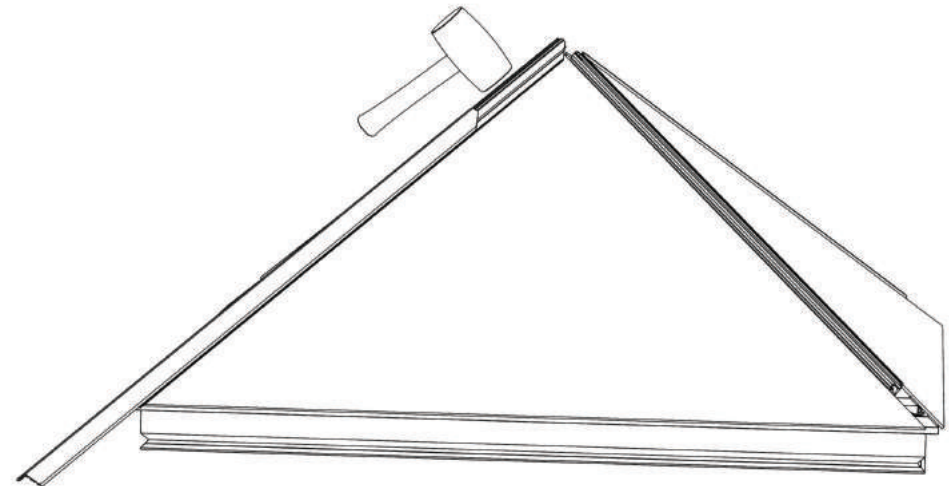

Repeat this for all 4 bars

ROOF MAKER

WORLD CLASS ROOFLIGHTS

Call us: 0116 269 6297

Mon-Fri 9-5pm

STEP 13 - CONTINUED...

iii) Slide the hip carriers up the hip bar, ensuring that the angled cut-outs line up perfectly.

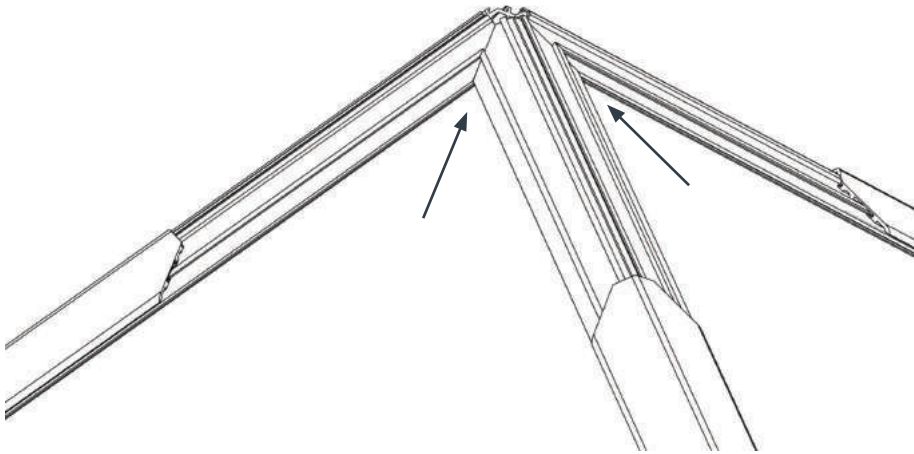

iv) Following this, slide your Hip top caps up into place using the same principal, lining them up equally at the top as shown.

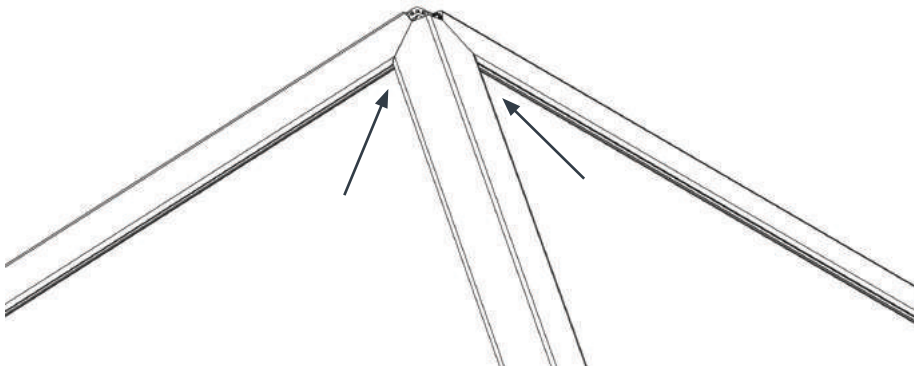

STEP 14 - FITTING THE HIP CAPS

i) If the plastic hip carrier is protruding from the bottom of the hip bars, use a hacksaw to carefully remove the excess, being careful not to damage the aluminium hip caps. Repeat at each corner if necessary.

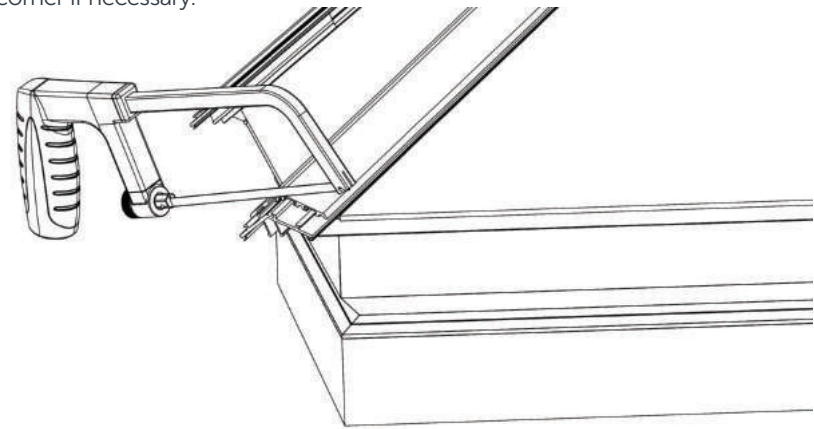

ii) Using a screw gun set at a low gear, attach the hip end caps as shown, being careful not to overtighten them. Repeat at all 4 corners of the lantern.

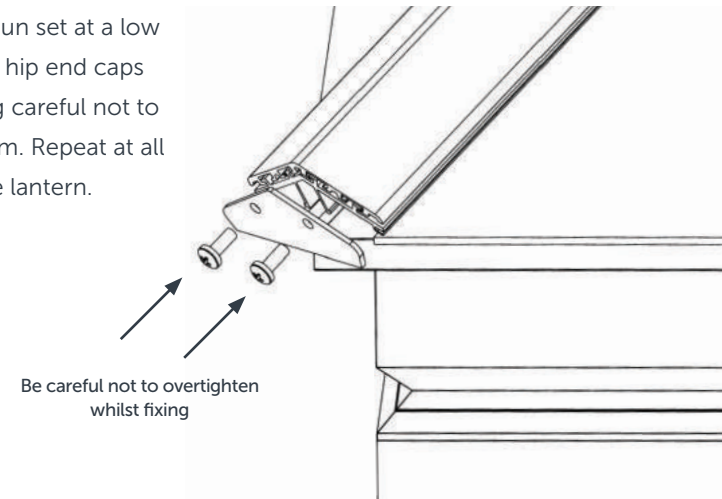

ROOF MAKER

WORLD CLASS ROOFLIGHTS

Call us: 0116 269 6297

Mon-Fri 9-5pm

STEP 15 - ATTACHING THE APEX CAP

- i) It is now time to fit the Apex cap. Fill the space in the apex, above the hip caps generously with silicone as shown and apply the apex cap.

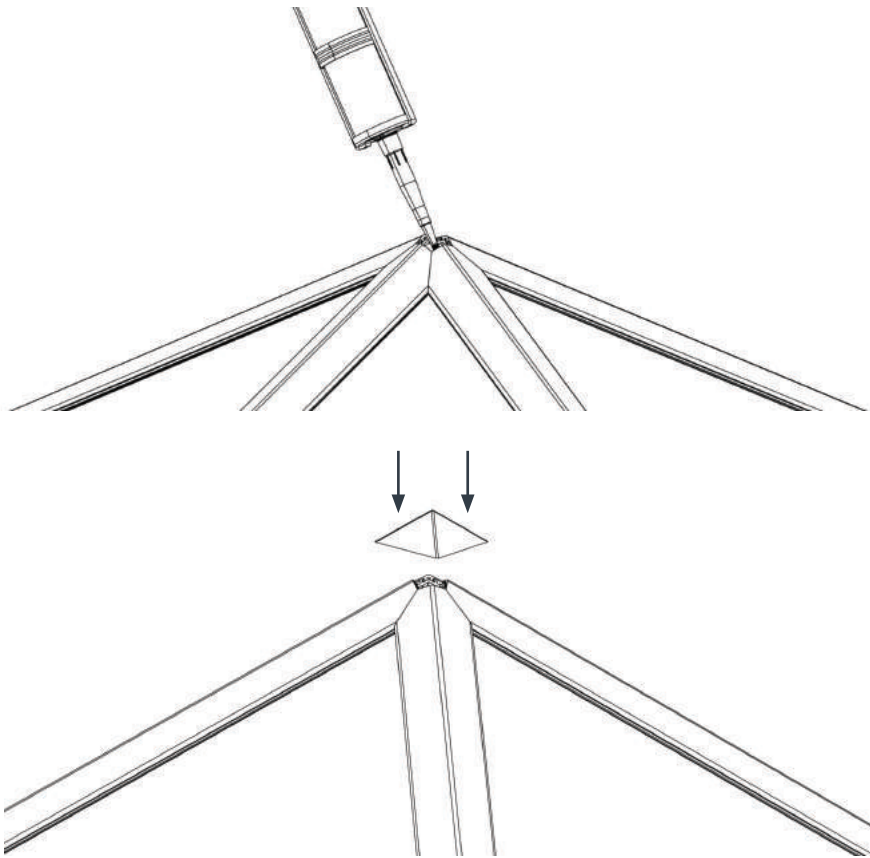

Ensure that the cap goes on neatly and level, wiping away any excess silicone with a damp cloth

STEP 16 - FIXING OF THE OUTER T-BAR SECTIONS

Now you are ready to complete the split in the glazing, by adding the longer, outer T-Bars.

- i) Generously fill the gap between the 2 glass panels as shown with the silicone provided.

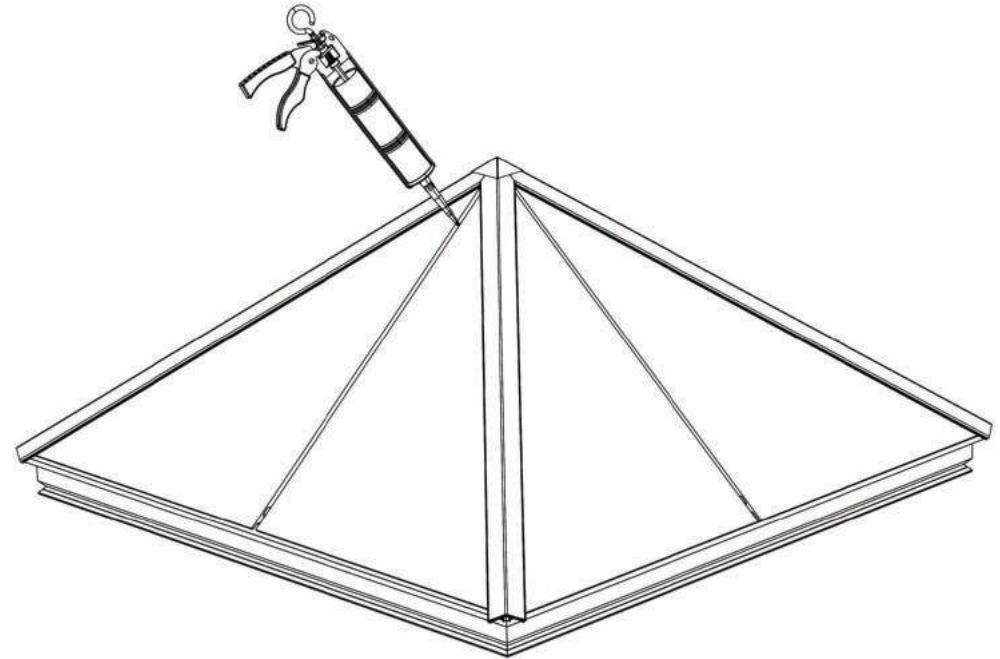

Repeat this on all 4 splits ready for your outer T-Bars

ROOF MAKER

WORLD CLASS ROOFLIGHTS

Call us: 0116 269 6297

Mon-Fri 9-5pm

STEP 17 - FIXING OF THE OUTER T-BAR SECTIONS

- i) Take one of the longer outer T-bars and remove all of the green protective film from the glazing tape, on both sides of the central spine. The end of the T-Bar with an angular cut should sit at the top. Push the T-bar into the silicone to complete the seal, ensuring the top of the T-bar is butted up tightly to the 2 hip bars where they meet. Press down firmly to ensure the glazing tape sticks to the surface of the glass all the way down.

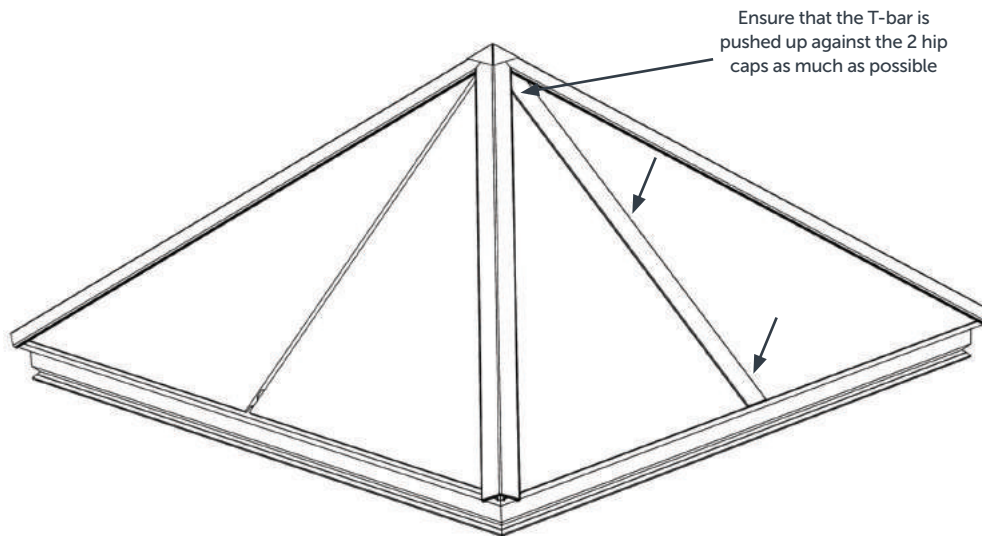

Repeat this on all 4 sides of the lantern.

STEP 18 - FINAL STAGE OF ASSEMBLY – SEALING THE UNDERSIDE OF THE GLASS PANELS

- i) Your Pyramid Roof Lantern is now nearly complete. All that remains, is to seal the underside of the bottom edge of the glass with silicone. Repeat this on all 4 sides.

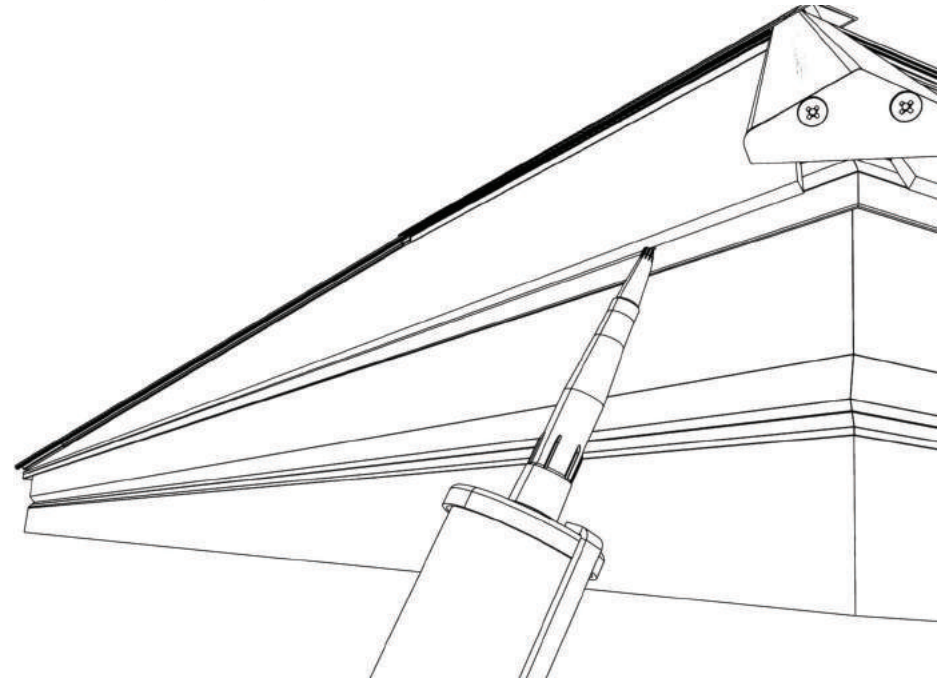

- i) From the inside of the lantern, gently remove all of the protective film from the glazing tape on the hip bars.

The assembly of your Pyramid roof lantern is now complete! You are now ready to flash the upstand with your chosen roof membrane.

ROOF MAKER

WORLD CLASS ROOFLIGHTS

Call us: 0116 269 6297

Mon-Fri 9-5pm

STEP 19.1 - FLASHING GUIDELINES - (sheet membrane)

i) Ensure the roof membrane is tucked right under the dedicated drip lip that sits just under the glass. This is important as it acts as the final weathering stage to avoid water ingress in this area. Take a look at the diagram below which illustrates this detail. If using a torch on felt, we recommend that you cut your membrane to the correct size, fold back and pre-heat with your heat gun. Only then should you apply it to the side of the unit. This will prevent you from damaging the unit by applying heat directly.

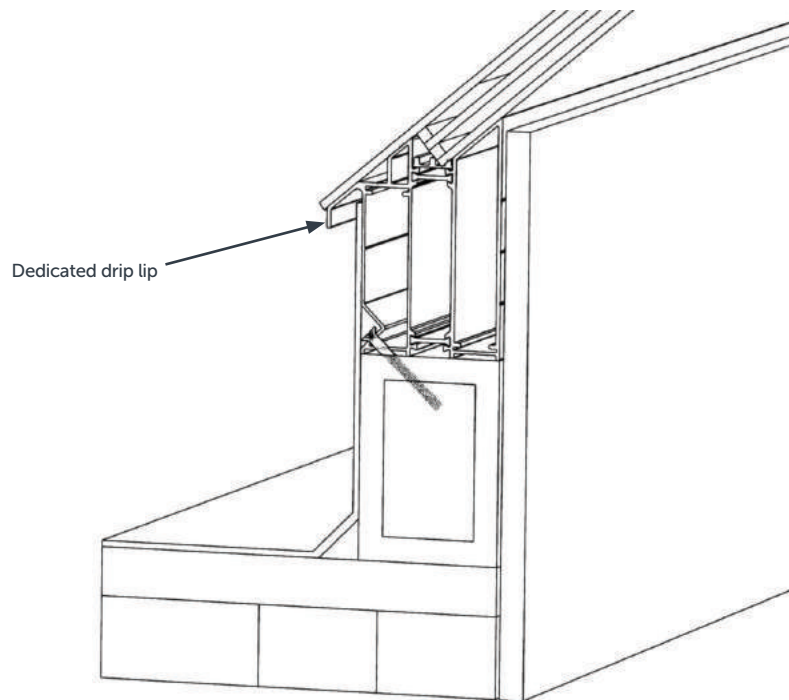

STEP 19.2 - FLASHING GUIDELINES - (GRP membrane)

i) If using GRP to finish the roof, you should silicone bond a 4mm plywood border around the upstand and kerb. Screw fix this into the timber kerb if you wish to make it more secure. This will provide a more suitable surface for the GRP to adhere to. Ensure that this goes right up underneath the drip lip as the below image shows. Also, ensure that the GRP layer is applied right up to and underneath the drip lip.

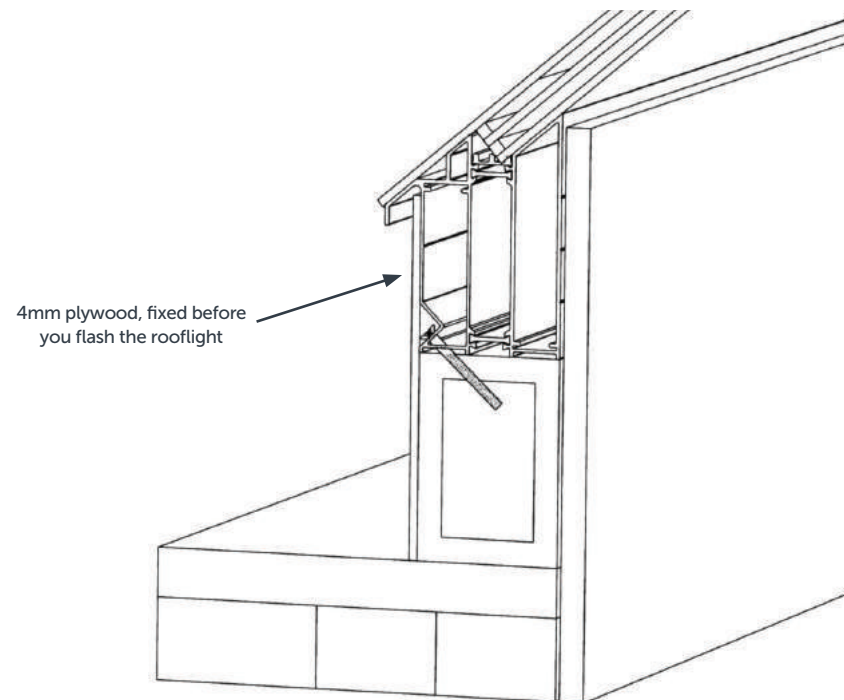

Your roof lantern assembly is now finished! For internal plaster finishing details please refer to the cross-section fitting guide, located on page 28 of this guide.

ROOF SECTION FITTING GUIDE

