

ROOF MAKER

WORLD CLASS ROOFLIGHTS



PRODUCT SPECIFICATION, PREPARATION OF ROOF AND FINISHING GUIDE

SLIMLINE[®]/PYRAMID ROOF LANTERNS BEING INSTALLED BY ROOF MAKER

DOUBLE GLAZED LANTERN
STANDARD PRODUCT SPECIFICATION

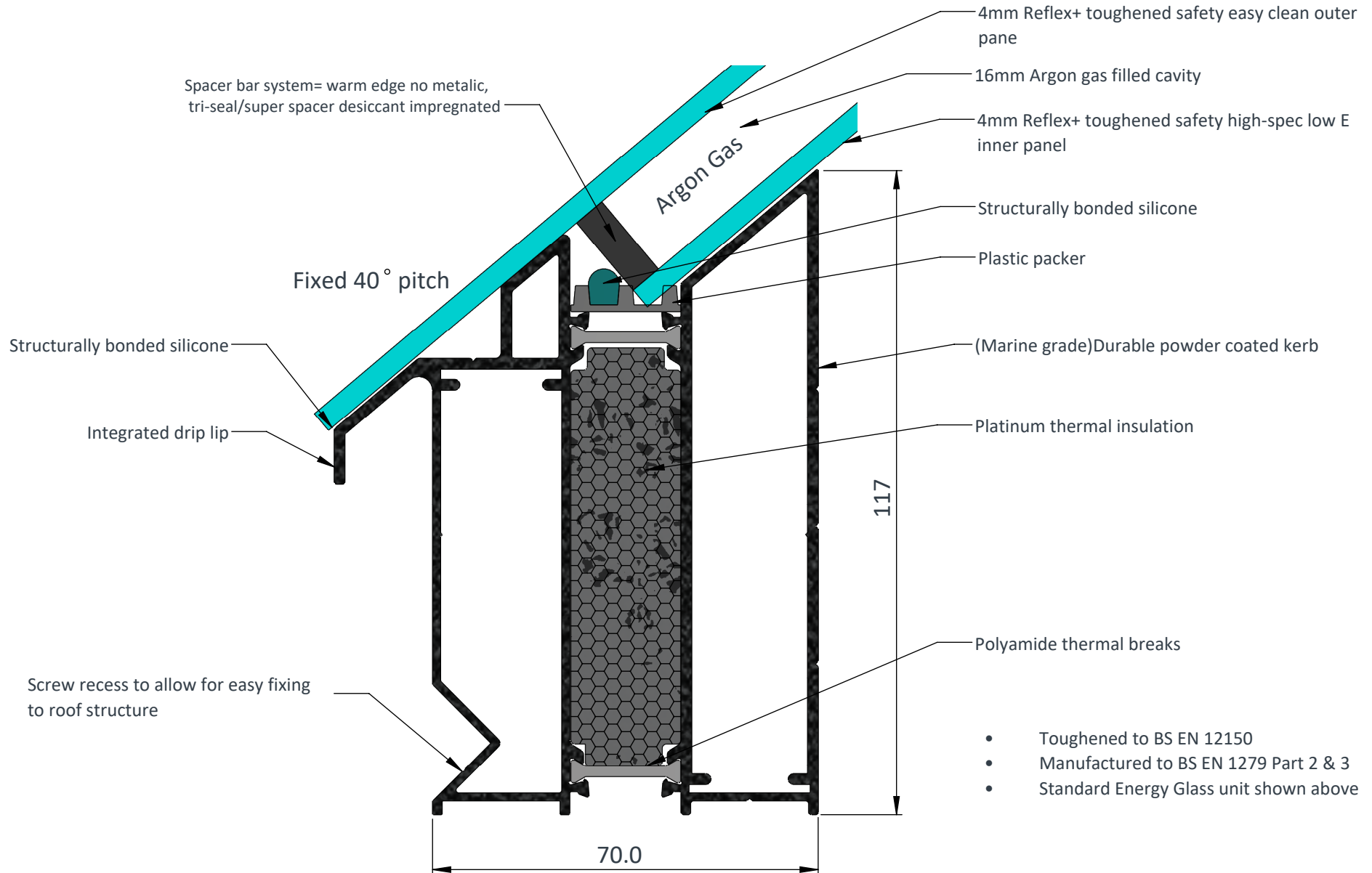

- Toughened to BS EN 12150
- Manufactured to BS EN 1279 Part 2 & 3
- Standard Energy Glass unit shown above

TRIPLE GLAZED LANTERN
STANDARD PRODUCT SPECIFICATION

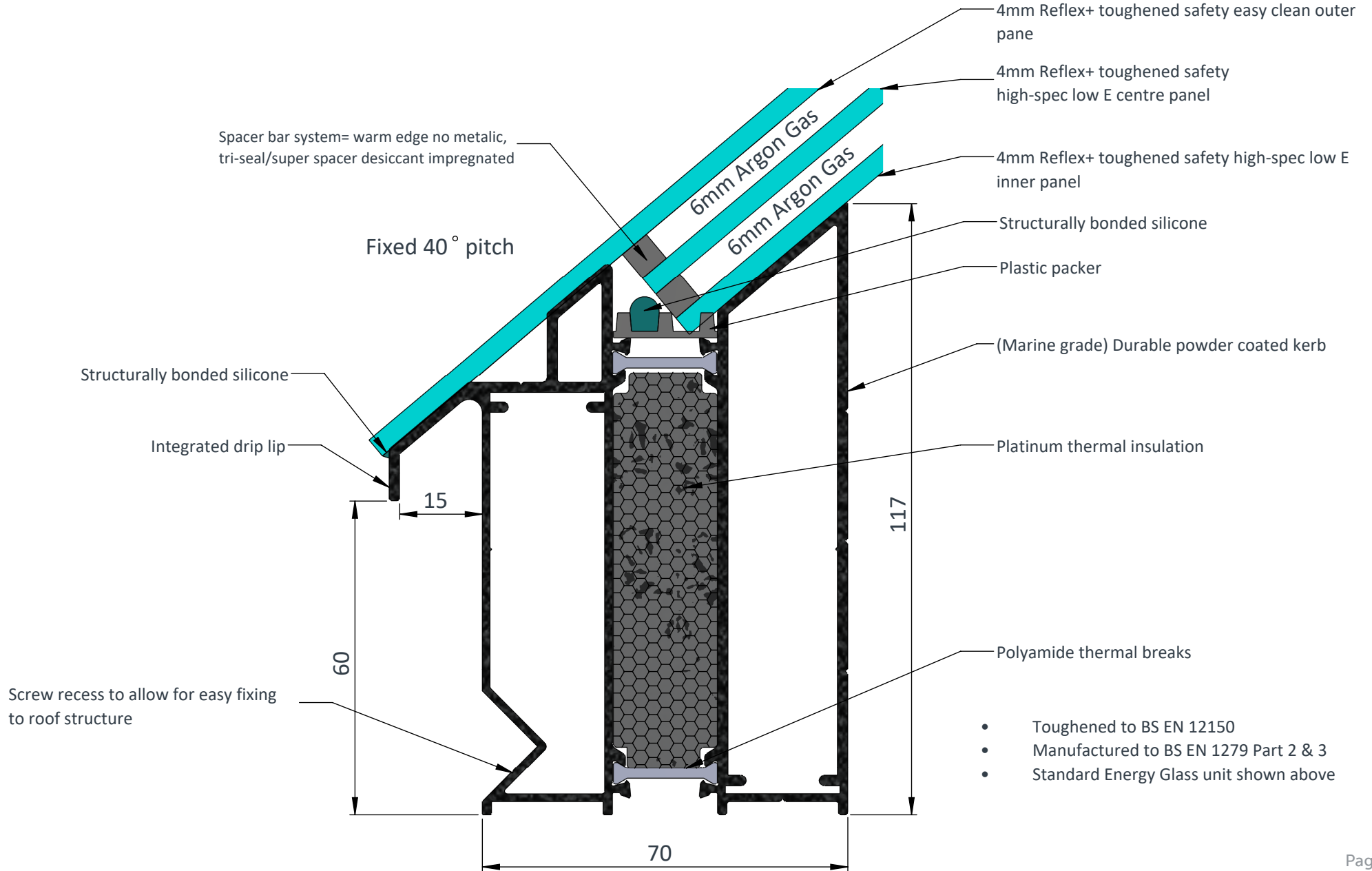

PREPARATION OF ROOF AND FINISHING GUIDE:

SLIMLINE[®]/PYRAMID ROOF LANTERNS BEING INSTALLED BY ROOF MAKER

CONTENTS

- **PAGE 4** Introduction to the guide
- **PAGES 5-8** Guidelines on creating the timber kerb in preparation for our installation team and the flashing of the unit required when the lantern has been installed (*if you have purchased a timber kerb from Roof Maker, this will be installed by our team prior to the lantern being installed*).
- **PAGES 9-12** Electronic vent wiring guides for both rocker switch and climate controlled units with rain sensor.
- **PAGES 13-19** You only need to read this section, as well as the first section, if you have a Slimline[®] lantern with opening vents and blackout blinds. Here, we set out the guidelines for cable location to explain how the frame must be prepared so that the vent motor cable can run through and into the property. This needs to be carried out by a qualified electrician, who will need to be present when our team of installers arrive on site.

PLEASE NOTE: For roof lanterns that feature blackout blinds, there is a blackout blind wiring guide available which we can provide, or is available to download in the technical section on our website. This also outlines the additional components that you will receive, such as the remote control and power pack.

PREPARATION OF ROOF AND FINISHING GUIDE:

SLIMLINE[®]/PYRAMID ROOF LANTERNS BEING INSTALLED BY ROOF MAKER

INTRODUCTION

This guide outlines the timber kerb requirements you will need to form around the opening in your roof in advance.

We also explain, in the latter part of the guide, the flashing requirements for the kerb and roof lantern following the installation. Please note that it is the responsibility of your builder/roofing contractor to carry out this work.

Also, when you have purchased a timber kerb from Roof Maker and have opted for us to install, we will also fit the timber kerb to the roof, prior to installing the lantern. However, it will still be your builder/roofing contractor's responsibility to flash the kerb and roof lantern when installation is complete, as per the guidelines provided in this guide. Roof Maker's installation teams do not carry out electrical works - If electronic opening vents or blackout blinds have been purchased, a qualified electrician must carry out the wiring of the installation after the roof lantern has been installed.

*IMPORTANT INFORMATION FOR LANTERNS THAT HAVE BOTH ELECTRONIC OPENING VENTS AND BLACKOUT BLINDS

If you have purchased a Slimline[®] lantern that has opening vent/s and a remote-controlled blackout blind, your qualified electrician will need to be present when our installation team arrive, to prepare the upstand section of the roof lantern. This involves drilling holes and inserting grommets for the vent motor cable to be taken through the frame when the lantern has been installed.

This needs to be done before the installation team fix the roof lantern to the timber kerb and assemble it. This is covered in the Cable Location Guide - Slimline Roof Lanterns with Electronic Vents and Blackout Blinds, which can be found on pages 13-19 of this guide.

PREPARATION OF ROOF AND FINISHING GUIDE:

SLIMLINE[®]/PYRAMID ROOF LANTERNS BEING INSTALLED BY ROOF MAKER

STEP 1 - CREATING YOUR TIMBER KERB

Create the structural opening in your roof at the same size of your lantern. So, for a 2000mm x 1000mm roof lantern, the structural opening must measure 2000mm x 1000mm.

Now build a level timber kerb around the opening you have formed in the roof, measuring 70mm in width, with a minimum height of 25mm from roof level (this can be increased if required). The internal dimension of your kerb should also match the size of the roof lantern/structural opening.

Check the timber kerb is perfectly square by measuring diagonally from corner to corner, before fully fixing to the roof.

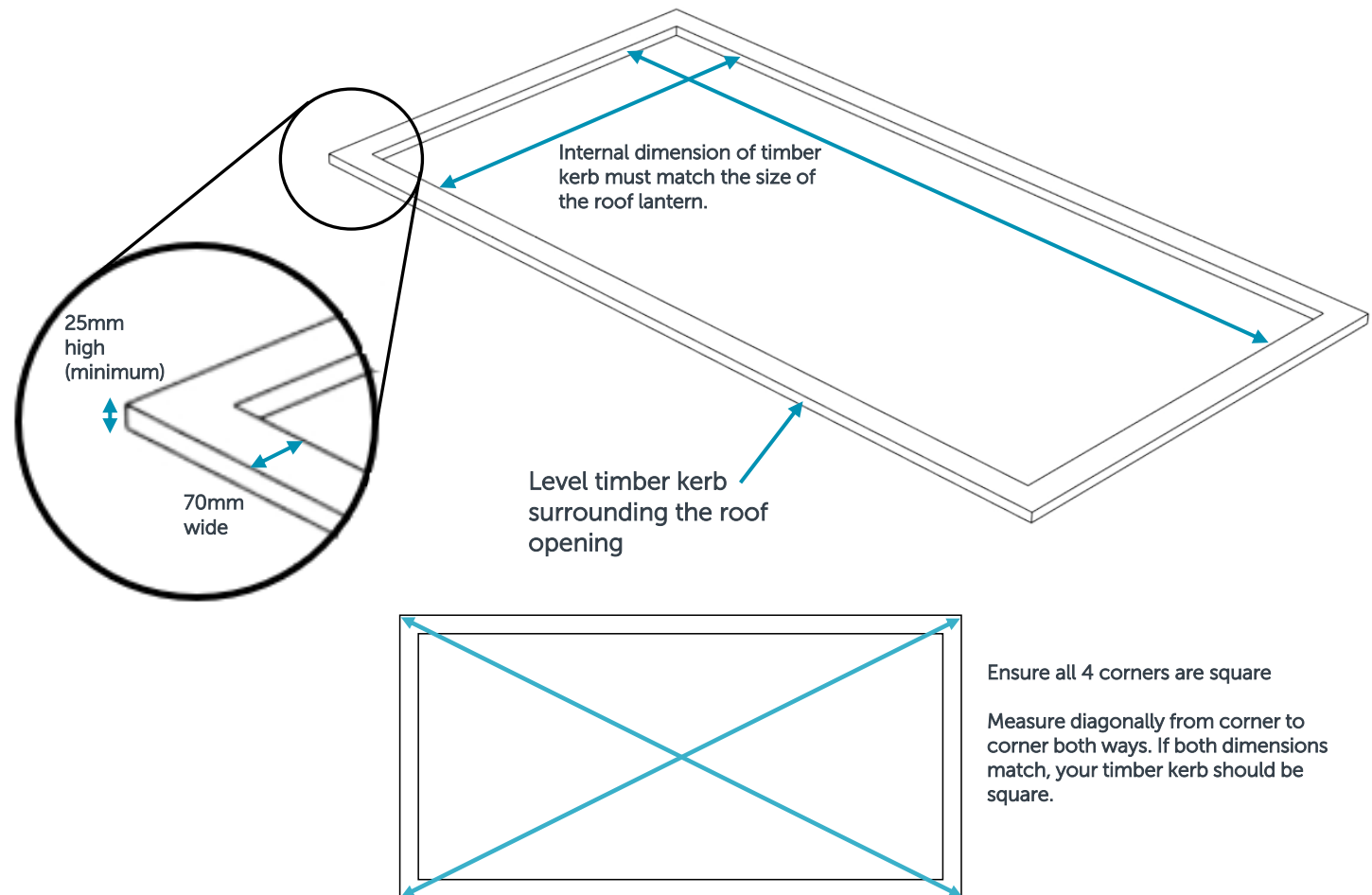

STEP 2 – ROOF MEMBRANE

We recommend you add the roof membrane after the lantern has been installed.

If you are applying the roof membrane in advance, we recommend you leave enough excess membrane around your prepared timber kerb, to be able to flash the roof lantern following the installation.

Ensure the membrane is folded back suitably so our installation team can get to the timber kerb to fix the lantern in place.

For certain types of roof membrane such as GRP, leaving excess is not an option, so in this scenario we recommend that the roof membrane is applied following installation of the roof lantern.

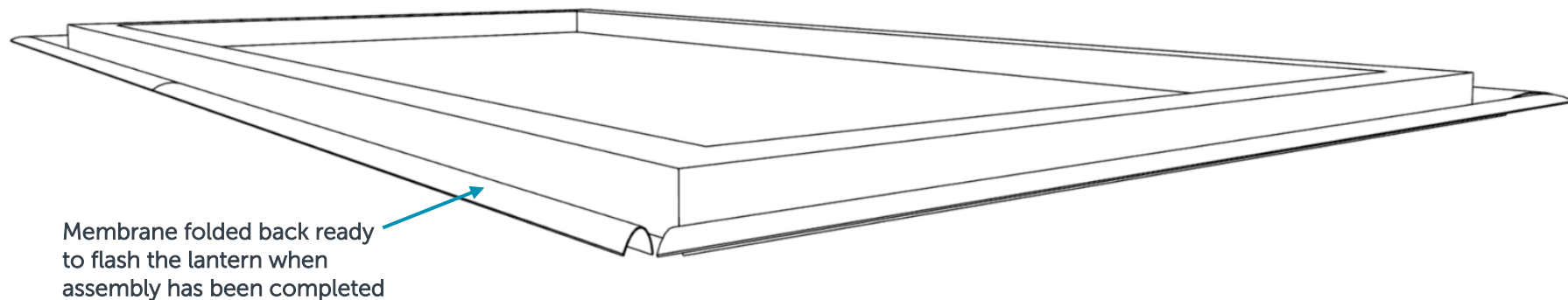

The timber kerb is now ready for our installation team to install your roof lantern.

Your sales representative will have issued you with a Build on Site form as part of the sales process. This outlines the site requirements from a Health and Safety aspect and must be completed and returned before we can book your installation date

The next section covers the flashing requirements that need to be carried out by your builder/roofing contractor after our team of installers have completed the installation. This is important as it acts as the final stage of weatherproofing the lantern.

STEP 3.1 – FLASHING THE ROOF LANTERN FOLLOWING INSTALLATION (SHEET MEMBRANE)

Ensure the roof membrane, when applied, is tucked right under the dedicated drip lip that sits just under the glass. This is important as it acts as the final weathering stage to avoid water ingress in this area. Please note, the diagram below which illustrates this detail. If using a torch on felt, we recommend that you cut your membrane to the correct size, fold back and pre-heat with your heat gun. Only then should you apply it to the side of the unit. This will prevent you from damaging the unit by applying heat directly.

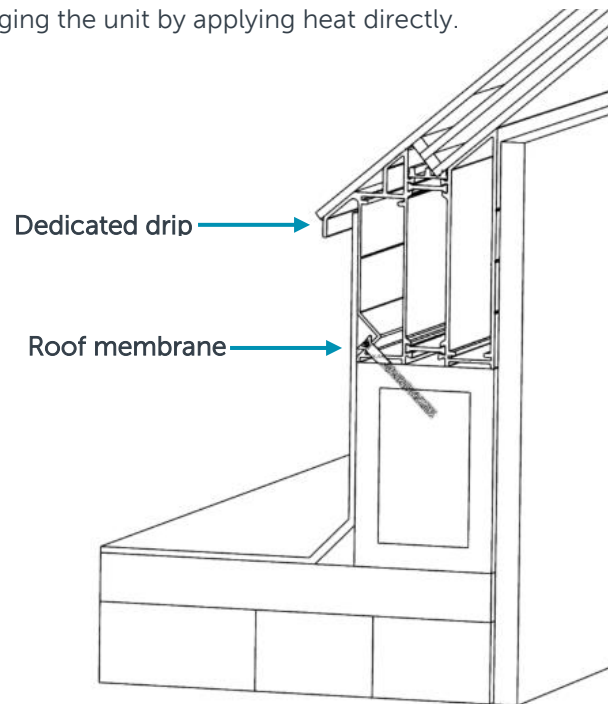

STEP 3.2 – FLASHING THE ROOF LANTERN FOLLOWING INSTALLATION (GRP MEMBRANE)

If using GRP to finish the roof, you should silicone bond a 4mm plywood border around the upstand and kerb. Screw fix this into the timber kerb if you wish to make it more secure. This will provide a more suitable surface for the GRP to adhere to. Ensure that this goes right up underneath the drip lip as the image below shows. Also, ensure that the GRP layer is applied right up, underneath the drip lip.

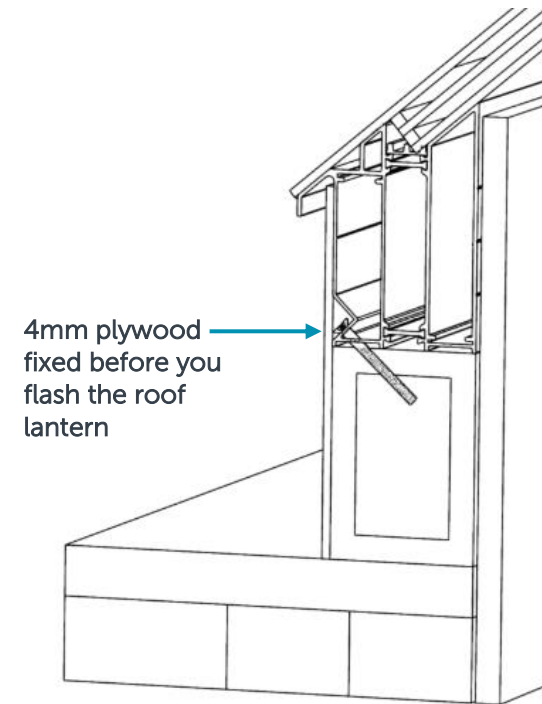

Your roof lantern assembly is now complete. For internal plaster finishing details please refer to the roof cross section fitting guide, located on page 8 of this guide. Following this, you will find the wiring guides for electronic vents.

ROOF SECTION FITTING GUIDE

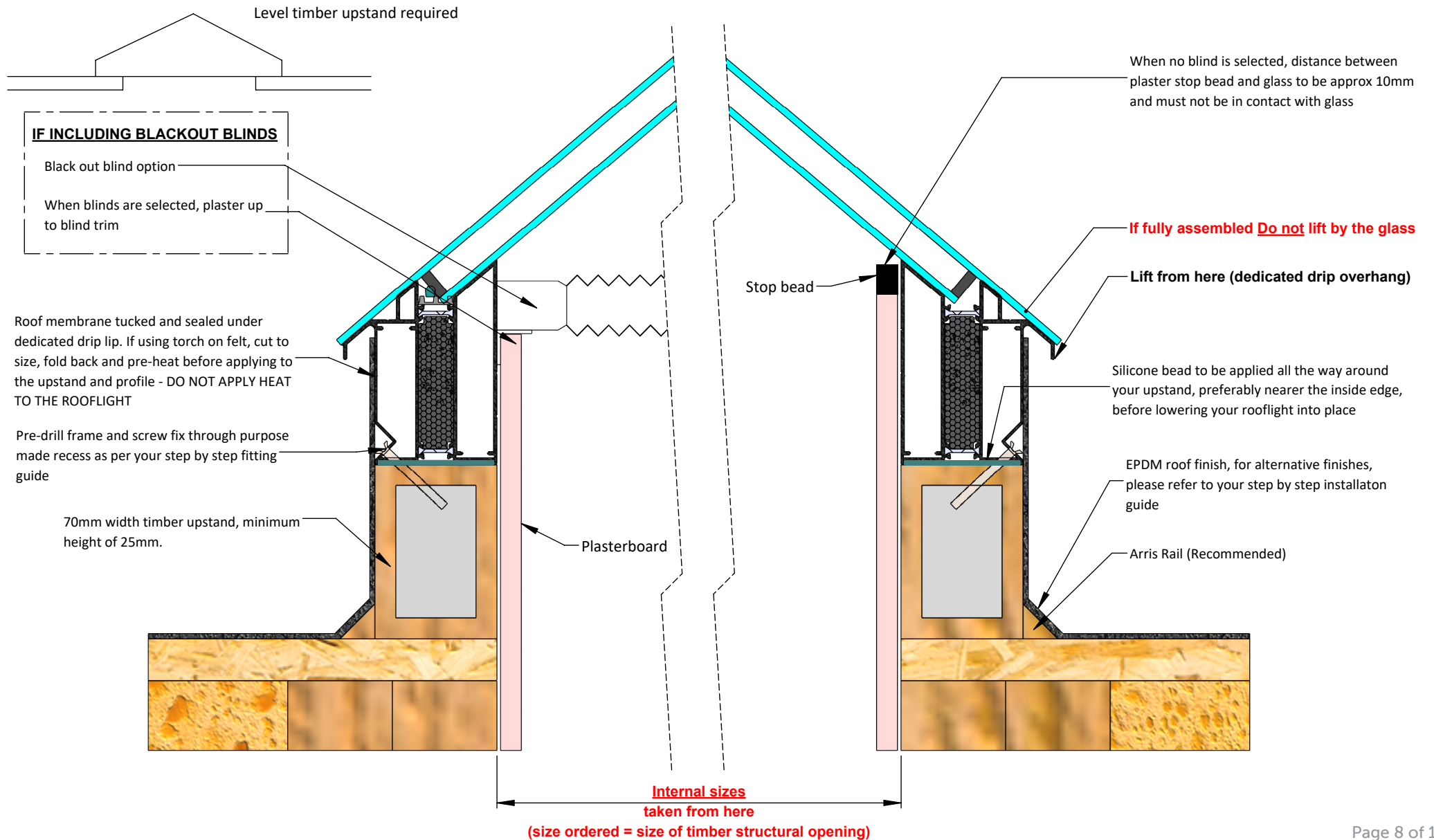

ROCKER SWITCH CONTROLLED OPENING VENT - WIRING GUIDE (3 CORE CABLE)

The diagram below illustrates how you need to wire in your opening vent to your switch, giving examples for both a single vent or when 2 vents have been included.

Please note - We provide a white plastic rocker switch when you have opted for a rocker switch controlled rooflight. If you would like to replace this for something that matches the remaining switches you have in the property, please ensure that it is a '2 way and off' retractive switch, that springs back to the central (off) position.

3 CORE - SINGLE MOTOR

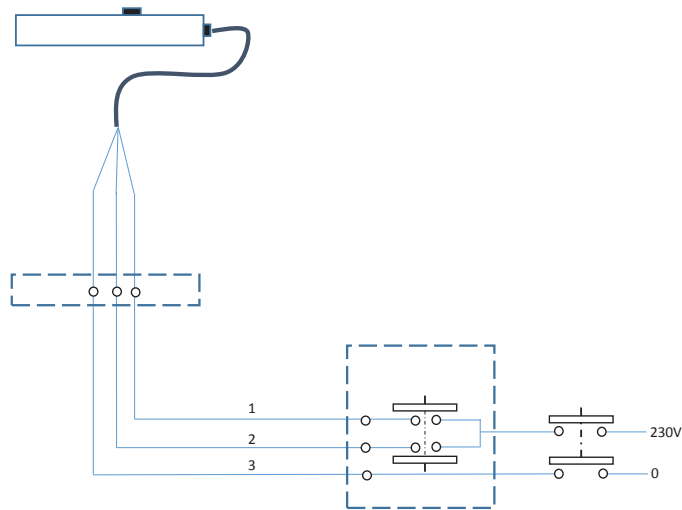

3 CORE - MULTIPLE MOTORS

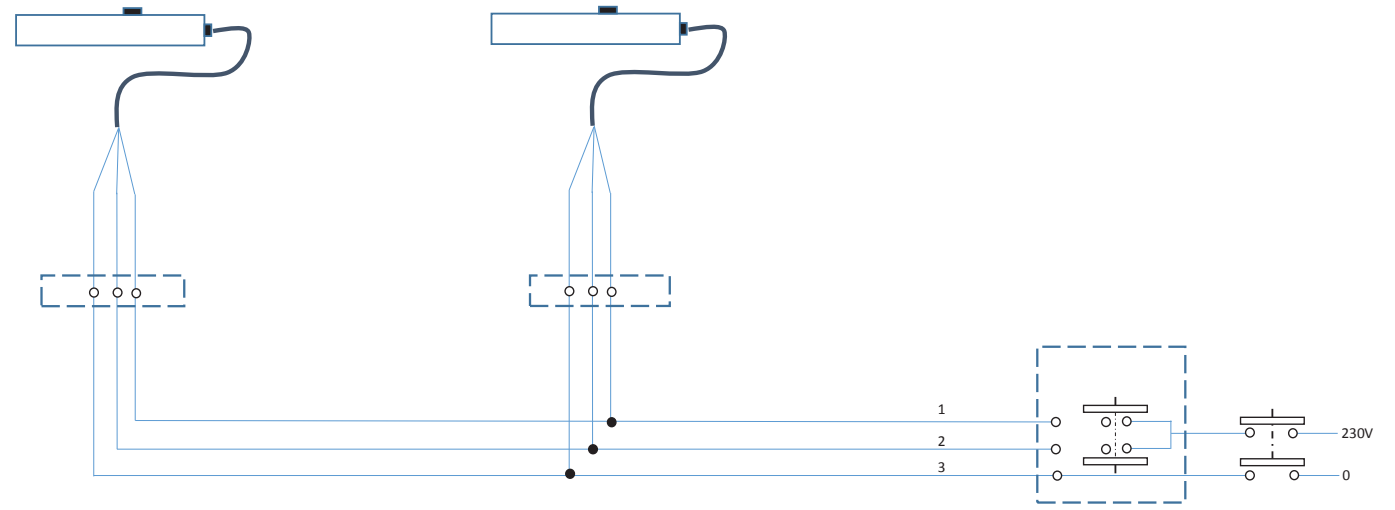

Colour	Number	Signal
Brown	1	Opens
Black	2	Closes
Blue/Grey	3	Common

Refers to both single and multiple motors.

ROCKER SWITCH CONTROLLED OPENING VENT - WIRING GUIDE (5 CORE CABLE)

The diagram below illustrates how you need to wire in your opening vent to your switch, giving examples for both a single vent or when 2 vents have been included.

Please note - We provide a white plastic rocker switch when you have opted for a rocker switch controlled rooflight. If you would like to replace this for something that matches the remaining switches you have in the property, please ensure that it is a '2 way and off' retractive switch, that springs back to the central (off) position.

5 CORE - SINGLE MOTOR

5 CORE - MULTIPLE MOTORS

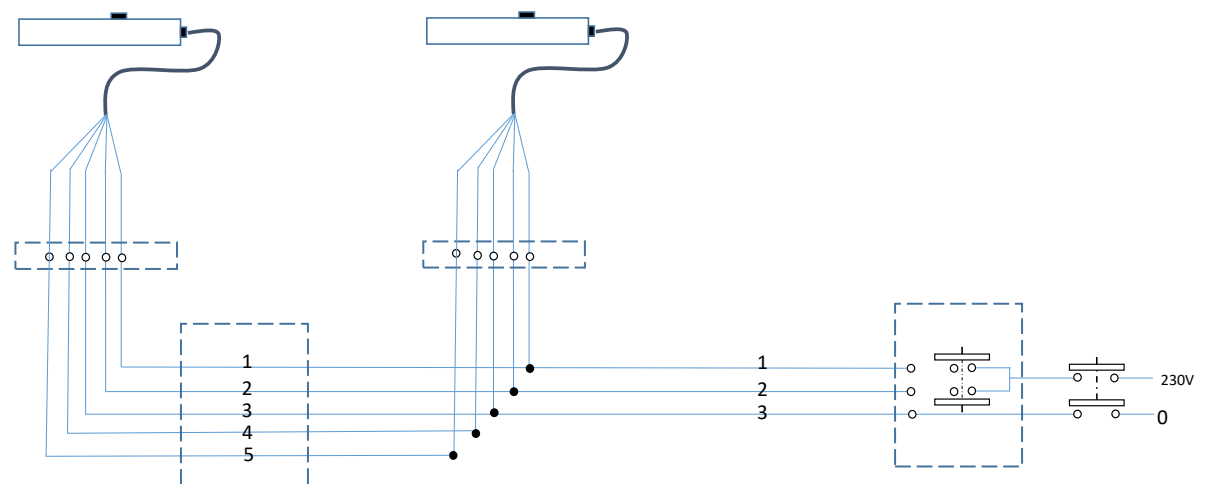
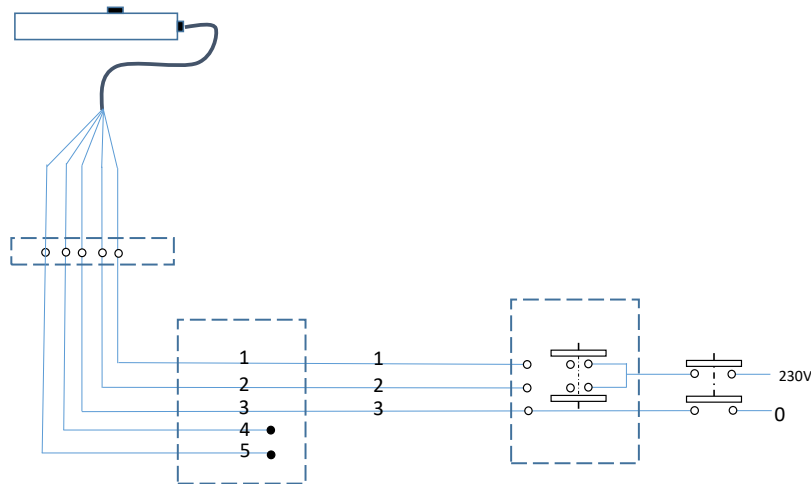

Colour	Number	Signal
Brown	1	Opens
Black	2	Closes
Blue	3	Common
Red	4	Sync
White	5	Sync

Refers to both single and multiple motors.

CLIMATE CONTROL AND RAIN SENSOR OPENING VENT - WIRING GUIDE

The below diagrams show the wiring in process for when you have chosen a climate-controlled operation with rain sensor.

ADVANCED OPERATIONS GUIDE

The default settings of our 100 series controller are suited to most user applications.

However, if you need to make advanced alterations such as; Thermostat, Actuator and Lock Calibration, then please use the following guide.



To enter 'advanced' setup set your unit to "AUTO" mode then press and hold the **AUTO/MAN** plus **SET +/-** buttons simultaneously for 5 seconds.

Your screen should now read..

ADV
SETUP

After a moment the screen will change to display

To Advance
Press SET +/-

Using **SET +/-** is how you scroll through the available options and saves each stage of any alteration.

Now press "**SET +/-**". The screen will read..

To + a value
Press Open

The Open button is used to increase any value.

Press "**SET +/-**" again. The screen will read..

To - a value
Press Close

The Close button is used to decrease any value.

Press "**SET +/-**" again. The display will read..

Proceed to
ADV Setup

Now you can proceed to the advanced setup options.

Press "**SET +/-**" again. The display will read..

Room Temp
is now XXc

'XX' being the current temperature in your room.

By using **Open(+)** and **Close(-)** you can calibrate the display temperature.

Press "**SET +/-**" again. The display will read

Full open
Cycle 013sec

013sec is the amount of time for the motor to operate and fully open - in most cases this default setting is adequate. You can of course, alter this setting for your actuator by pressing the **Open(+)** and **Close(-)** buttons.

Press "**SET +/-**" again. The display will read..

Opening
Temp = 22c

This relates to the temperature that the room must reach before the actuator will operate.

You can alter this setting by pressing the **Open(+)** and **Close(-)** buttons.

Press "**SET +/-**" again. The display will read..

Closing
Temp = 18c

This relates to the temperature that the room must fall to before the actuator will operate.

You can alter this setting by pressing the **Open(+)** and **Close(-)** buttons.

Press "**SET +/-**" again. The display will read..

AUTO LOCK
MODE OFF

Using autolock is a security feature that prevents the unit from being used without entering a passcode first. You can turn this on or off by pressing the **Open(+)** and **Close(-)** buttons.

Press "**SET +/-**" again will take you back to **AUTO MODE**

The unlock sequence is:

Button 2 [AUTO/MAN]
Button 1 [OPEN]
Button 3 [SET +/-]
Button 4 [CLOSE]

Continued on
next page...

FREQUENTLY ASKED QUESTIONS

Q. Where is the temperature sensor?

A. The Ventec 100 Series comes with an internal temperature sensor.

cleaning the metallic head with a soft damp cloth. We recommend the rain sensor is cleaned on a quarterly basis.

Q. Where do i mount my temperature sensor?

A. If you have opted for the external temperature sensor, the location is entirely at your discretion. We would recommend a position that gives a good average reading of the desired location, ideally at least 1300mm from the floor. *You can choose to position the thermostat a maximum of 30m away from the control panel.*

Q. it has recently stopped raining but my windows have not opened again?

A. In Auto mode the 100 series controller has a built in time delay of 5 minutes between the rain sensor drying and the unit becoming fully operational. This will be indicated by the presence of the Rain LED on the front panel. For the unit to operate the current temperature will need to be higher than your desired opening temperature. In manual mode you should have full control of the unit.

Q. Only the set+/- button on my panel does anything?

A. This means your panel has been locked. To unlock your unit see the instructions on the back page.

Q. My display shows 0.0 - is this correct?

A. This indicates a problem with the thermostat wiring. Check the wiring and that all connections have been correctly made.

Q. Can i change the default lock/unlock code?

A. No. The code has been preset to avoid the need for a complete system reset should the new code be forgotten.

Q. How many actuators will the 100 series operate?

A. The 100 series has a 5 amp capacity.

Q. My rain sensor seems to have become less responsive?

A. Check the unit has not slipped or fallen into an undesired position and try

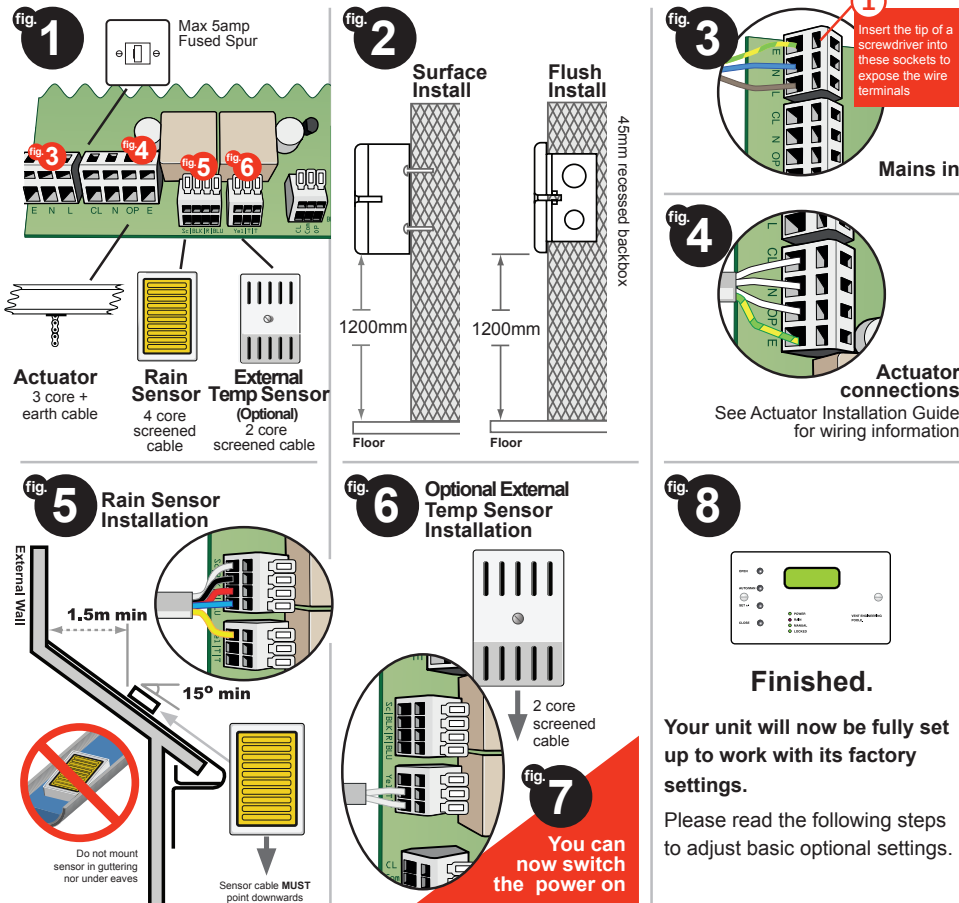

Additional user settings

Preset Opening Temperature

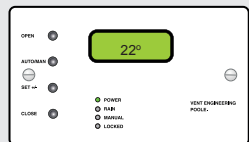

To adjust opening temperature



In Auto mode, hold 'A' & repeat press 'B'

Preset Closing Temperature



To adjust closing temperature

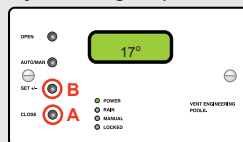

In Auto mode, hold 'A' & repeat press 'B'

We advise a difference of at least 2° between the opening and closing temperature.

To manually open and close

Press and hold **AUTO/MAN** for 2 seconds until **MANUAL** light comes on then use the **OPEN** or **CLOSE** buttons to adjust the window position.

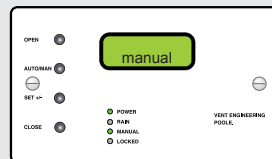

Press and hold **AUTO/MAN** for 2 seconds to return to automatic mode.

CABLE LOCATION GUIDE:

SLIMLINE[®] ROOF LANTERNS WITH ELECTRONIC VENTS AND BLACKOUT BLINDS

INTRODUCTION AND TOOLS REQUIRED

When you have opted for a Slimline[®] roof lantern with electronic vent/s and a blackout blind, the electrician will need to drill through the lantern's built in upstand profile in order to run the vent motor cable through it. The requirements for this are outlined in this guide and will prevent the blind being obstructed by the vent actuator cabling, ensuring that the blind will open and close as intended.

Opening vents are always positioned on the longer sides of the lantern, so it will be the longer side of the built in upstand that you will need preparing. If you have 2 vents, it will be both sides of the unit you will be preparing, as you will have 1 vent positioned on each side. This preparation has to be done before the lantern is positioned and fixed to your timber kerb.

Notching a small groove onto the inside/internal face of your kerb and reveal below will also be required, which will allow the actuator cable to run into the property, where it comes out of the bottom of the lantern's built in upstand. These grooves, however, can be created when the lantern is properly positioned and fixed onto the timber kerb (outlined in the guide). Tools and materials required for the preparation are as follows;

- Drill with 10mm HSS drill bit
- Tape measure and pencil
- 2x 10mm rubber grommets (per vent), suitable for a 2mm wall thickness – ensure the grommets have a large enough hole to comfortably run the motor cable through them
- Hammer and chisel or routing tool (to create the internal groove/s required in the timber structure, for the cabling to run into the property)
- Masking tape (optional)

CABLE LOCATION GUIDE:

SLIMLINE[®] ROOF LANTERNS WITH ELECTRONIC VENTS AND BLACKOUT BLINDS

PREPARATION GUIDE

When our installers arrive with your Slimline[®] roof lantern, the upstand section will be fully assembled and already house the blackout blind. The blind will be fully open and you will see that it sits along the width of the unit, at the side that it would retract to. If you have a single vent, you will need to make a decision at this point as to which side you would like the opening vent to be positioned, which would always be positioned in the centre, on the longer side of the rooflight. The side you locate the vent is down to your preference. If you have 2 vents, there will be one positioned on either side of the unit, centred on each of the longer sides

STEP 1

On the (longer) side you have chosen for your vent to be located, measure the upstand section from the inside corner to inside corner. Use this measurement to then find the centre point of the long side. Make a mark at this centre point, close to the top edge of the profile, above the white blind trim.

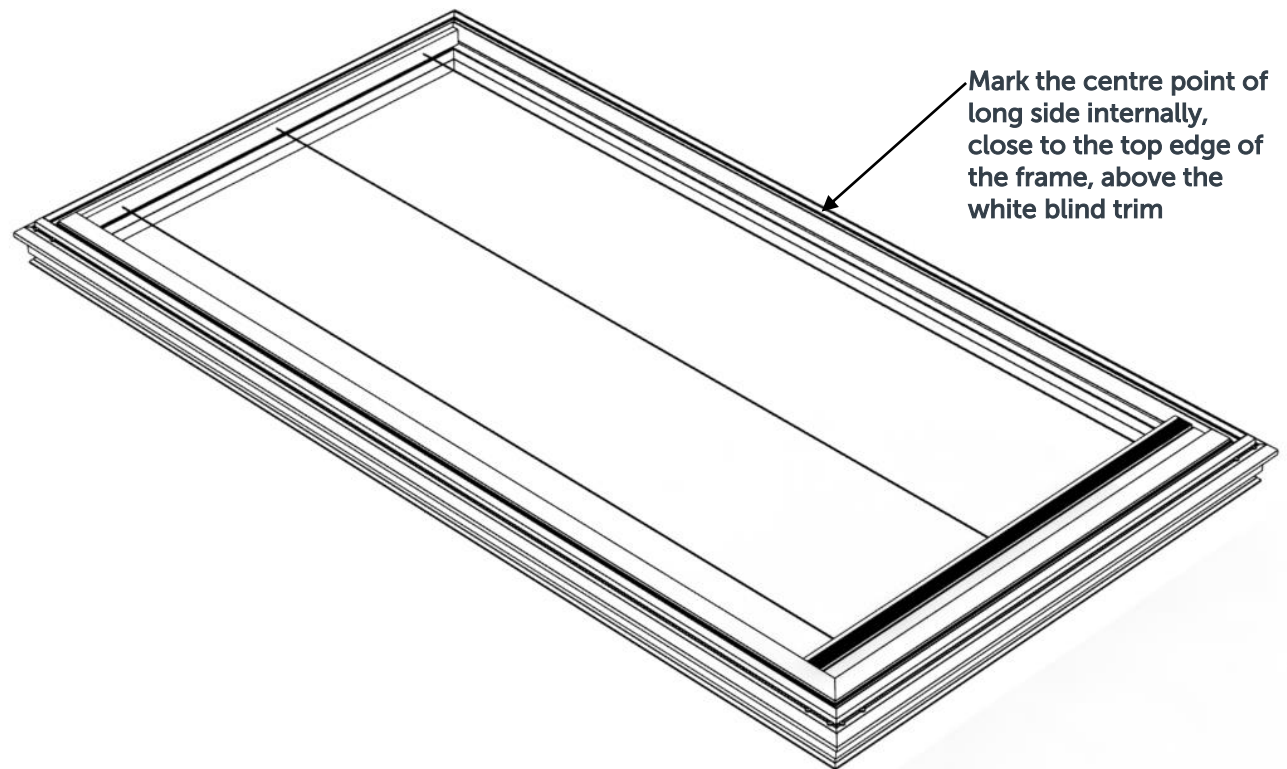

CABLE LOCATION GUIDE:

SLIMLINE[®] ROOF LANTERNS WITH ELECTRONIC VENTS AND BLACKOUT BLINDS

STEP 2

Looking toward the internal face of the upstand, measure to the right of your centre mark by 200mm, making another mark here, close to the top edge.

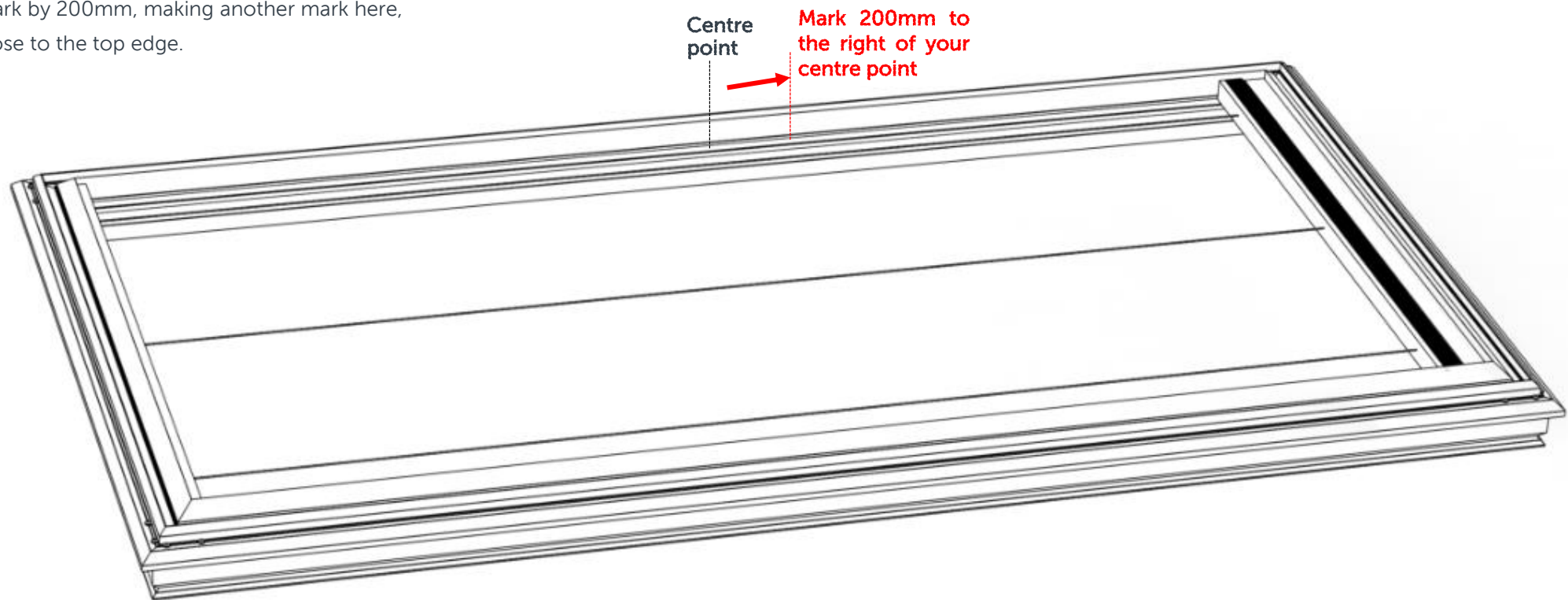

CABLE LOCATION GUIDE:

SLIMLINE[®] ROOF LANTERNS WITH ELECTRONIC VENTS AND BLACKOUT BLINDS

STEP 3

At your 200mm mark, measure down from the top edge of the profile by 15mm and make a mark. Where the 2 marks meet, use your 10mm drill bit to drill a hole. Take your time and ensure that the hole is only made in this surface and doesn't go through any deeper.

Tip – you can place masking tape onto the frame where the hole needs to be drilled, which will stop the drill slipping and also prevent the powder coating from chipping in this area.

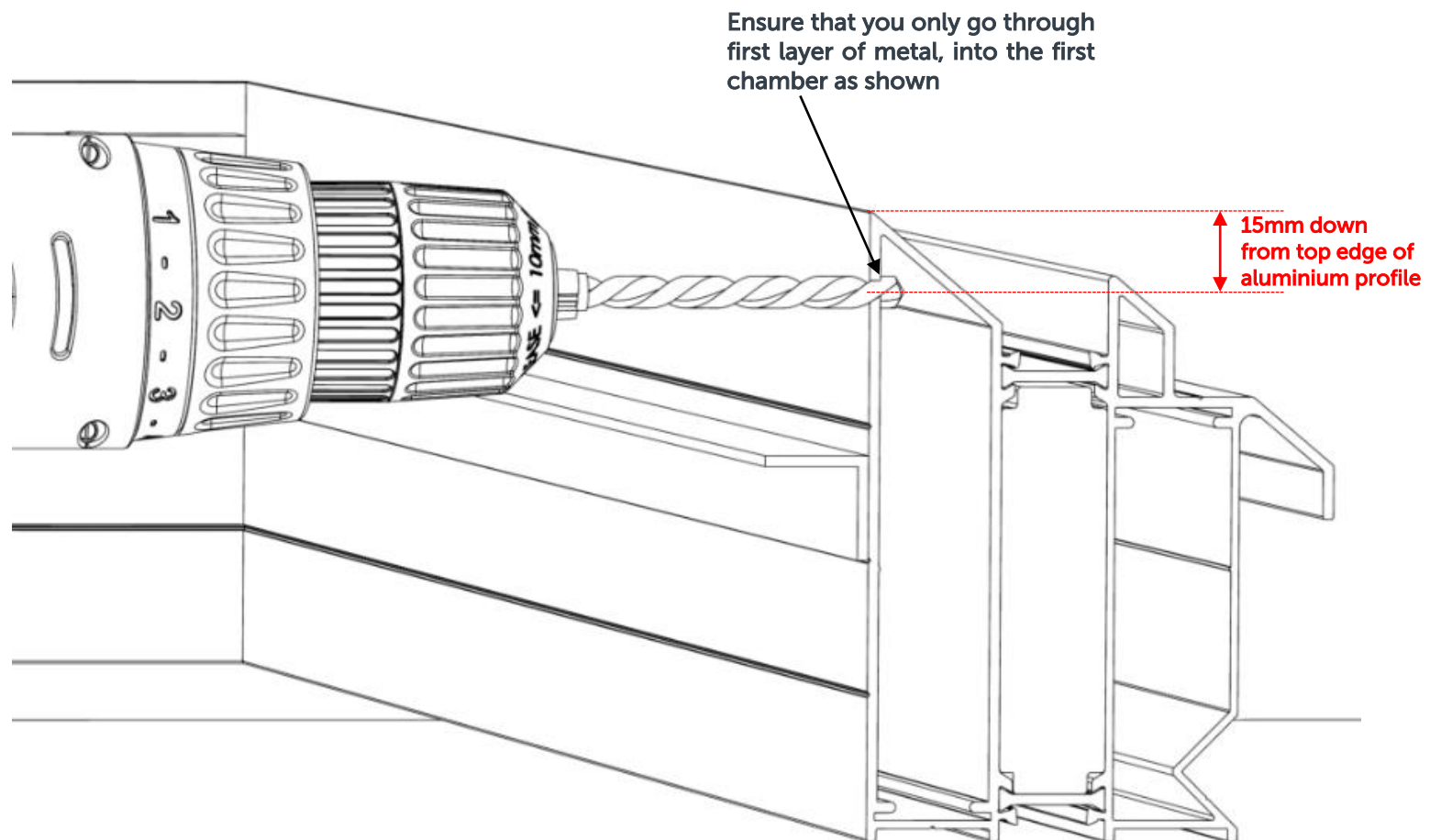

CABLE LOCATION GUIDE:

SLIMLINE[®] ROOF LANTERNS WITH ELECTRONIC VENTS AND BLACKOUT BLINDS

STEP 4

You now need to drill a 10mm hole through the bottom of the upstand, vertically level with the first hole you made on the inside face, through to the inside chamber of the upstand.

You can also use the masking tape here to prevent the drill slipping, as mentioned in the previous step.

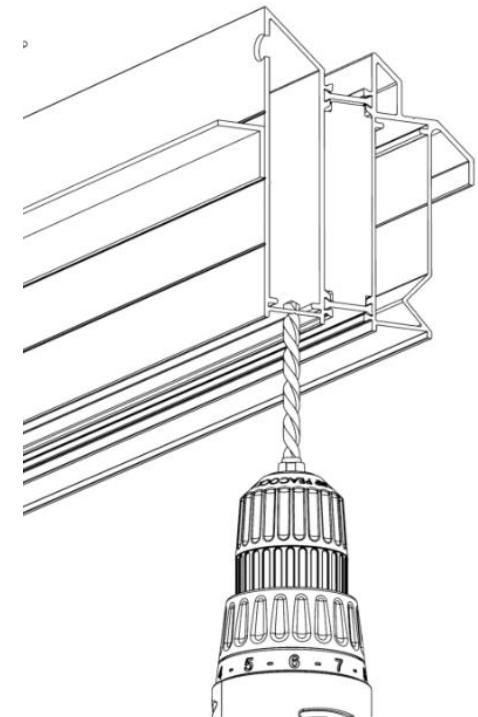
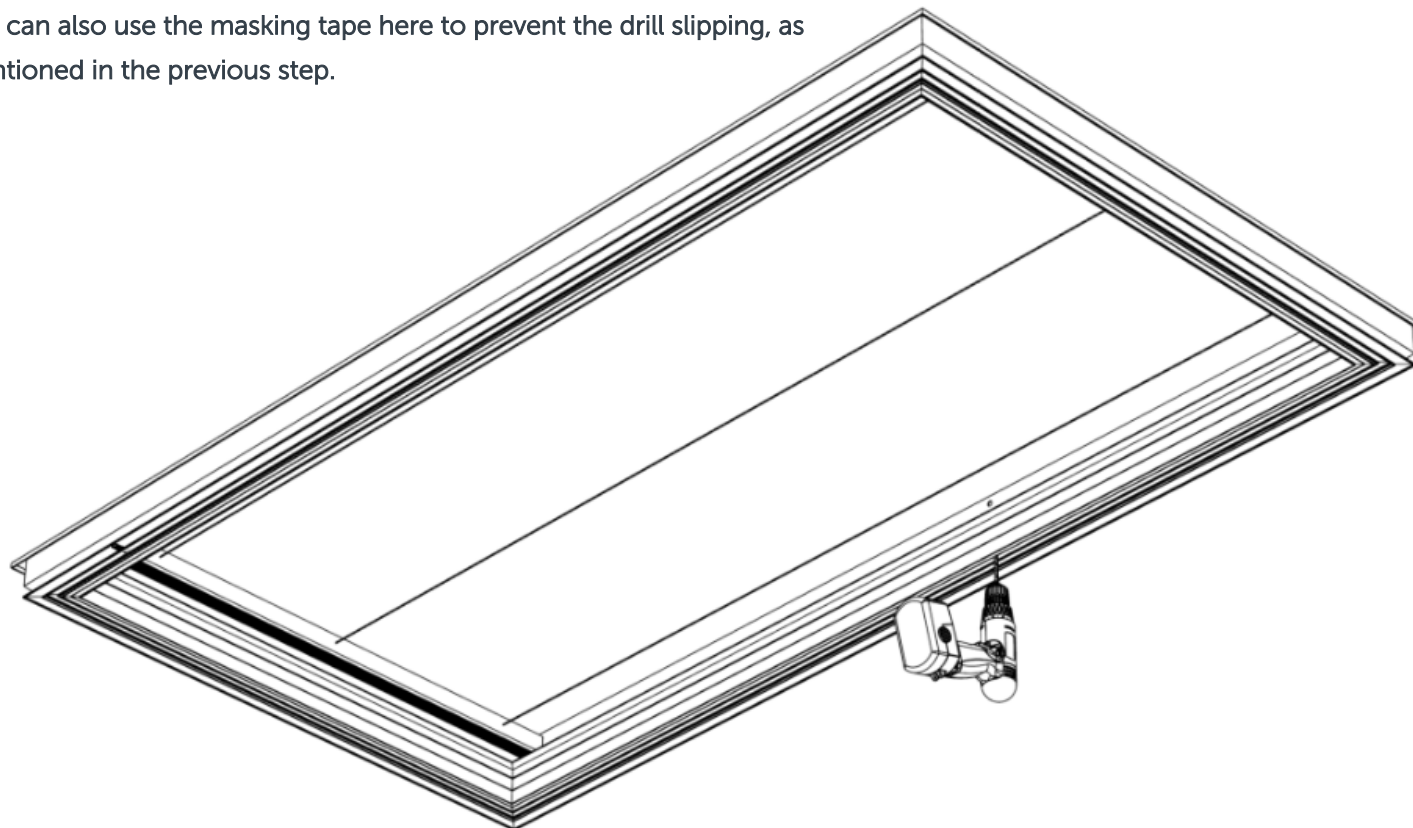

You will be drilling into the first chamber again, as shown, vertically in line with the first hole you drilled.

CABLE LOCATION GUIDE:

SLIMLINE[®] ROOF LANTERNS WITH ELECTRONIC VENTS AND BLACKOUT BLINDS

STEP 5

Place the rubber grommets into both holes you have just drilled. If you have 2 vents, repeat this process on the opposite side of the roof lantern following the same instructions. The upstand section is now prepared.

The installers can now fix the upstand to the timber kerb and proceed to assemble the rest of the roof lantern. When the lantern installation is complete, proceed to the next step.

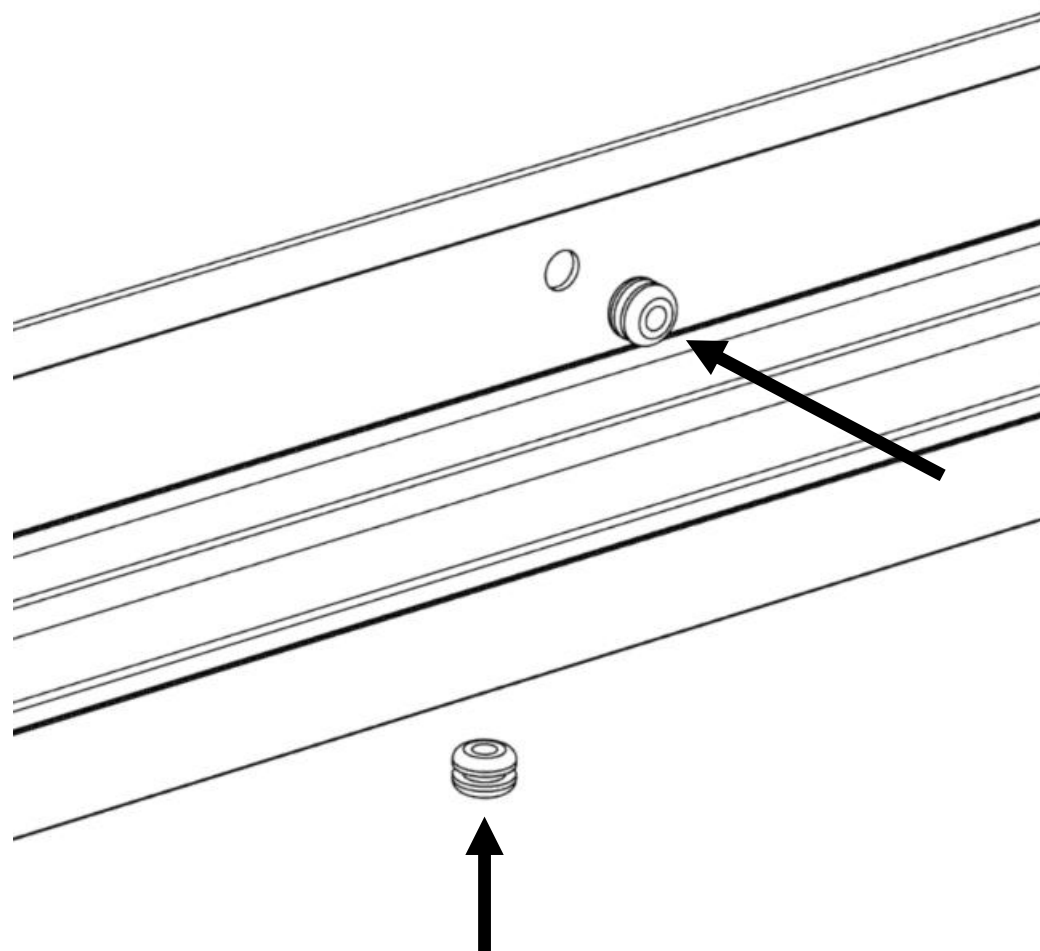

CABLE LOCATION GUIDE:

SLIMLINE[®] ROOF LANTERNS WITH ELECTRONIC VENTS AND BLACKOUT BLINDS

STEP 6

Now the lantern is installed, you can create the groove/s required in the timber reveals, to house the vent actuator cabling. Mark a line down the timber reveal, vertically level with the grommet's position. Use the line as a guide to notch a groove into the timber structure. This will house the cabling when it is fed through the upstand, and allow it to run into the property. Ensure the groove is deep enough to expose the hole you have prepared in the bottom of the upstand and house the cable sufficiently, so it will not obstruct the plasterboard when applied to the reveals later on.

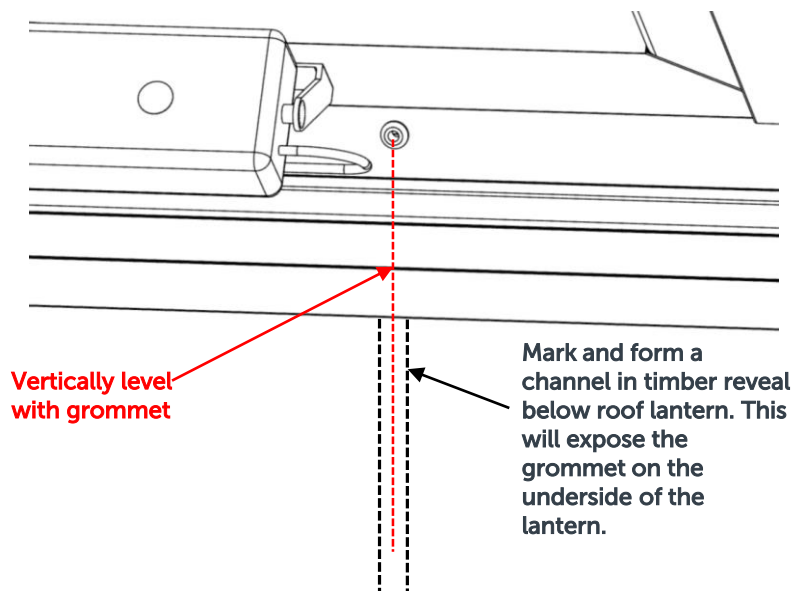

STEP 7

You can now run the cable that comes from the vent actuator through the hole in the upstand frame above the blind trim, out through the bottom of the unit and into the groove you have formed in the reveal. You will need to extend the cable to the chosen location of your rocker switch/climate control panel. Once the vent has been fully wired in and checked, the builder can then proceed to plaster the inside reveals, as per the finishing guidelines shown in the installation guide. **Be sure to instruct the installer not to put plasterboard fixings where the cabling is located in the reveal.**

