

ROOF MAKER

WORLD CLASS ROOFLIGHTS



PRODUCT SPECIFICATION & INSTALLATION GUIDE FLAT PACKED SLIMLINE[®] ROOF LANTERN WITH OPENING VENTS

DOUBLE GLAZED SLIMLINE® LANTERN
STANDARD PRODUCT SPECIFICATION

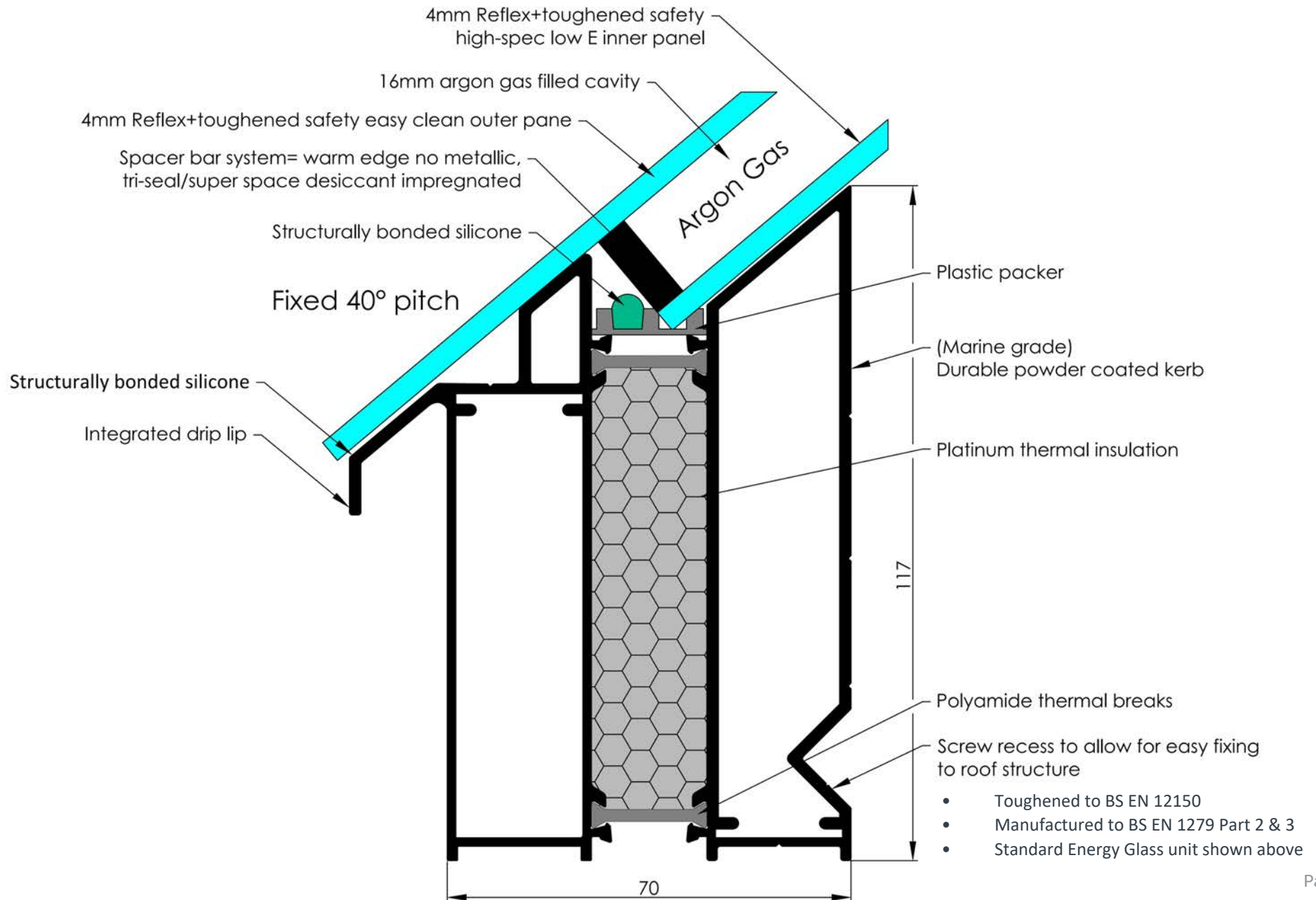

TRIPLE GLAZED SLIMLINE® LANTERN
STANDARD PRODUCT SPECIFICATION

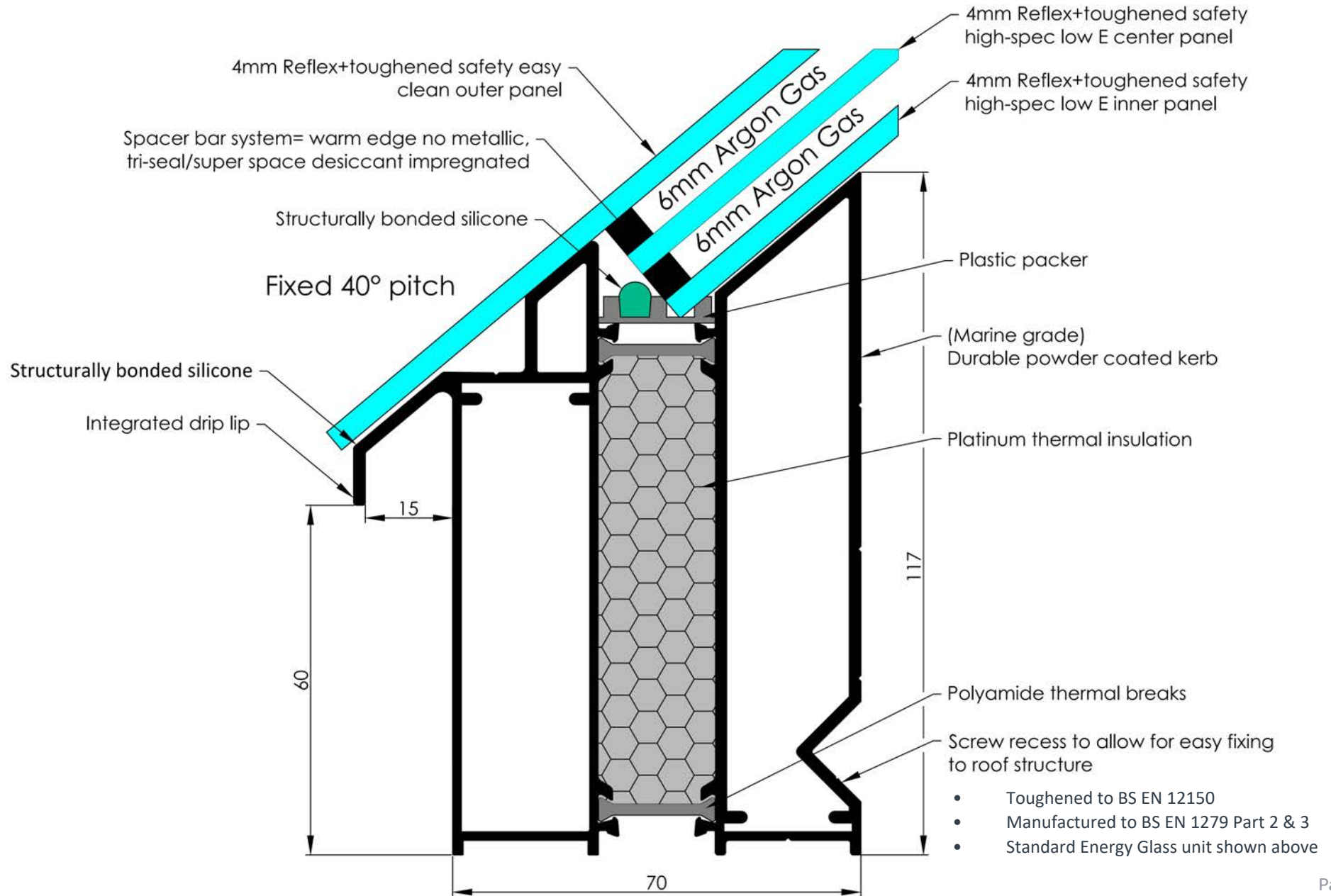

SLIMLINE® STEP-BY-STEP INSTALLATION GUIDE

THANK YOU FOR CHOOSING ROOF MAKER, WE HOPE YOU ARE DELIGHTED WITH YOUR NEW ROOFLIGHT.

Our roof lanterns have been designed with speed and ease of construction in mind, so that you don't need to be a professional installer to build and fit them.

This guide will take you through an easy-to-follow process to ensure you build and install your roof lantern correctly, but if you do need advice or help, our technical support team are available to provide guidance.

Wiring guides for lanterns with both rocker switch controlled vents and climate controlled vents with rain sensor, can be found on pages 30-33.

IMPORTANT: For lanterns that have electronic opening vents and blackout blinds

Your electrician will need to prepare the upstand frame before you fix the lantern to the timber kerb. This involves drilling holes and inserting grommets so that the vent motor cable can be ran through the upstand frame and in to the property. This will need to be done to ensure the blackout blind can travel unobstructed, back and forth along the length of the rooflight. A cable location guide, which features instructions on how to prepare the upstand and what you will require, can be found on pages 34-40.

The blackout blind wiring guide is a separate document, which we can provide or is available to download in the technical section on our website. This also outlines the additional components that you will receive, such as the remote control and power pack.

GUIDE WEIGHTS FOR THE SLIMLINE® ROOF LANTERN*

SLIMLINE® ROOF LANTERN		
Size (mm)	Double glazed Weight (KG)	Triple glazed Weight (KG)
600 x 400	20	24
1000 x 700	42	53
1500 x 1000	76	99
2000 x 1000	97	128
2500 x 1000	118	156
3000 x 1000	139	185
3500 x 1000	160	214
4000 x 1000	181	243
5000 x 1000	223	300
1500 x 1200	87	115
2000 x 1200	112	149
2500 x 1200	136	182
6000 x 1200	390	538
3000 x 1500	193	262
3500 x 1500	222	303
4000 x 1600	266	364
5000 x 1600	328	451
3000 x 2000	247	339
4000 x 2000	322	445

*Please add 10kgs per vent, to the above weights

THE GUIDE EXPLAINED

This guide covers the installation of a Slimline® roof lantern with electric or manual opening vent(s).

If your Slimline® roof lantern hasn't been specified with opening vent(s) and has a standard 4 pane configuration, you will need to follow the 'Slimline® 4 Pane Configuration' installation guide instead. If you haven't received this, it is available to download from the technical section on our website.

If your Slimline® roof lantern hasn't been specified with opening vent(s) and has additional panes and splits in the glazing, you will need to follow the 'Slimline® Additional Glazing Splits' installation guide instead. If you haven't received this, it is available to download from the technical section on our website.

IMPORTANT - VENT ORIENTATION

On any dark coloured lanterns (grey/black/custom RAL) the roof-vent must be fitted to a non-south facing side.

ROOF MAKER

WORLD CLASS ROOFLIGHTS

Call us: 0116 269 6297

Mon-Fri 9-5pm

WHAT DO I NEED TO CONSTRUCT MY ROOF LANTERN?

IN ADDITION TO YOUR SLIMLINE® ROOF LANTERN KIT, YOU WILL NEED:

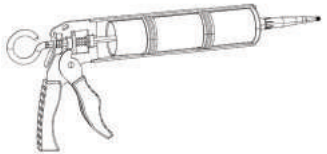

Silicone adhesive sealant (recommended Dow Corning 791 or similar)- Required for the fixation of your upstand to the prepared timber kerb. **Silicone required when glazing the unit will still be provided as part of your kit.**

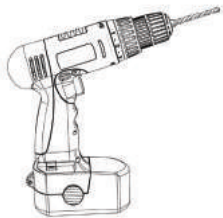

Drill with HSS drill bit – To pre-drill the aluminium upstand to form holes for your timber screws when fixing to your timber upstand.

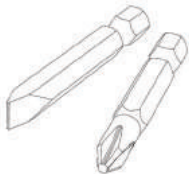

Posi drive and flathead drill bits – For fixing of screws and bolts throughout the assembly.



Timber screws – Measuring at least 50mm in length. Required to fix the upstand to the prepared timber kerb.

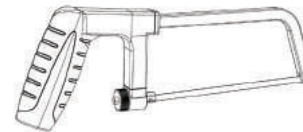

Hacksaw - To trim the plastic cap carriers as advised in the fitting guide.

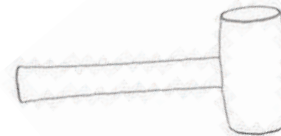

Rubber mallet – To carefully tap components into place such as carriers and cappings.

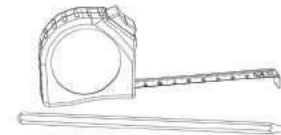

Tape measure and pencil

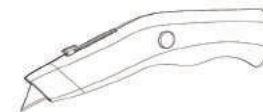

Stanley knife

Damp cloth – To wipe off any excess silicone as required.















COMPONENT CHECKLIST

The images below show a component checklist that you will receive as part of your flat packed kit. This will be attached to the box which contains most of your components. Not all of the components listed will be applicable to your chosen specification. Your exact inventory will be outlined, along with quantities, as part of the list. This also includes imagery to help you locate the various components and familiarise yourself with what you will be working with.



Page 1 of 2

SUMMERY LANTERN COMPONENT CHECKLIST			
JOB REF # NAME			
FRAME COLOUR			
NUMBER OF GLASS PANEES			
SIDE			
PACKED BY (print name)			
CHECKED BY (print name)			

COMPONENTS FOR STANDARD CONFIGURATION LANTERN (NO GLAZING SPLITS)			
IMAGE	COMPONENT	QTY	TICK
	Aluminum ridge body (with end blocks and fixings) - prepared with glazing tape		
	Pyramid apex hip attachment block (pyramid lanterns only)		
	Plastic ridge cap carrier		
	Aluminum ridge cap cover		
	Aluminum hip body - prepared with glazing tape		
	Plastic hip cap carrier		
	Aluminum hip cap cover		
	Pre-assembled upstand (prepared with nuts and bolts for hip body attachment)		
	Aluminum ridge end caps		
	Aluminum pyramid apex cap (pyramid lanterns only)		
	Plastic glazing washers		
	Aluminum hip end caps		
	Black counter-sink screws		
	Allen key (in case adjustment of ridge is required)		
	Sealant tube		



Page 2 of 2

SUMMERY LANTERN COMPONENT CHECKLIST			
JOB REF # NAME			

COMPONENTS FOR ADDITIONAL GLAZING SPLITS/VENT INSTALLATION (IF APPLICABLE)			
IMAGE	COMPONENT	QTY	TICK
	T-bar outer (longer than inner T-bar, with cut out) - prepared with glazing tape		
	T-bar inner - prepared with glazing tape		

COMPONENTS FOR LARGER LANTERN KITS (EXCEEDING 3000 X 1500 WITH UNASSEMBLED UPSTAND SECTIONS) (IF APPLICABLE)			
IMAGE	COMPONENT	QTY	TICK
	Upstand section (in lengths)		
	Nut and Bolt		
	Corner cleat type A		
	Corner cleat type B		
	Straight cleat (for large lanterns, joining upstand sections, end on end)		
	Self-drilling screws		

COMPONENTS FOR OPENING VENTS (IF APPLICABLE)			
IMAGE	COMPONENT	QTY	TICK
	Vent housing (includes winding mechanism or motor)		
	Pre-glazed vent lid		
	Chrome winding pole (for manual vents)		
	Rocker switch (if applicable)		
	Climate control (rain sensor unit, if applicable)		

Make sure to read through all steps and understand the requirements before beginning assembly.

Please take precaution when moving heavy objects and working at height - be sure to use suitable equipment.

ROOF MAKER

WORLD CLASS ROOFLIGHTS

Call us: 0116 269 6297

Mon-Fri 9-5pm

STEP 1 - PREPARE THE TIMBER KERB

i) Before you begin the construction of your new roof lantern, you will have installed the timber kerb. The size of the internal opening should reflect the exact size of the roof lantern you have ordered. For example, the roof opening should measure exactly 2m x 1m for a unit that measures 2m x 1m.

Your timber kerb should measure 70mm in width, to match the width of the built-in upstand that you are going to assemble. We recommend a minimum height of 25mm from roof level, but this can be increased if required.

The upstand should be perfectly level and we also recommend that you check the corners have a 90° angle, by measuring it diagonally from corner to corner before starting the assembly of the roof lantern.

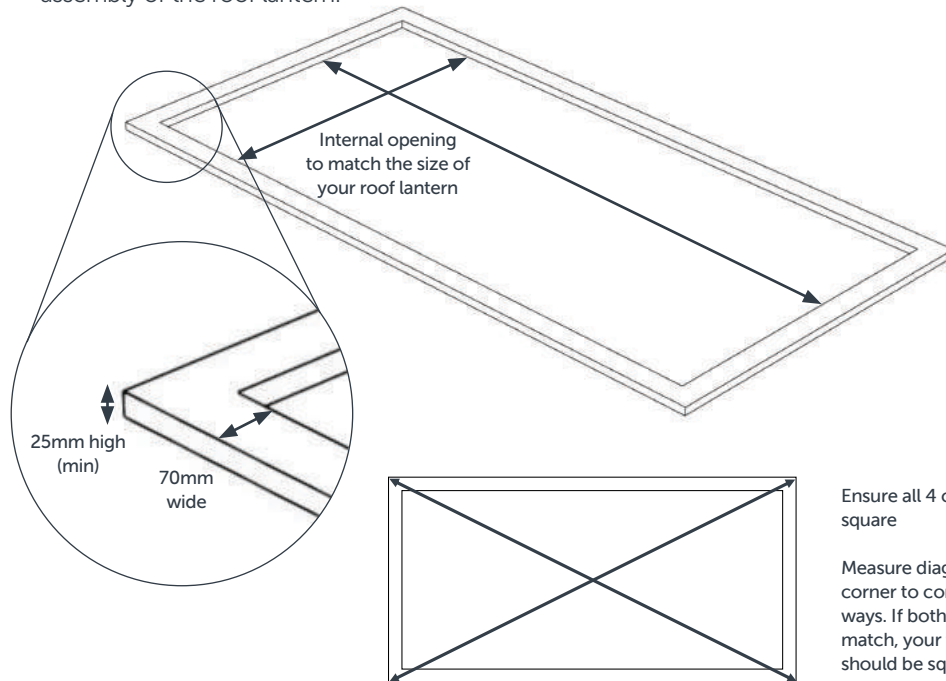

Ensure all 4 corners are square

Measure diagonally from corner to corner both ways. If both dimensions match, your timber kerb should be square.

STEP 2 - PREPARE THE ROOF MEMBRANE

i) We recommend that you apply your roof membrane after installing your roof lantern, to avoid damaging or piercing it during the installation.

If you have added your roof membrane on top of your plywood deck already, please ensure that you leave enough excess material around the timber kerb to flash the roof lantern upstand. This can be folded back out of the way until your roof lantern is installed.

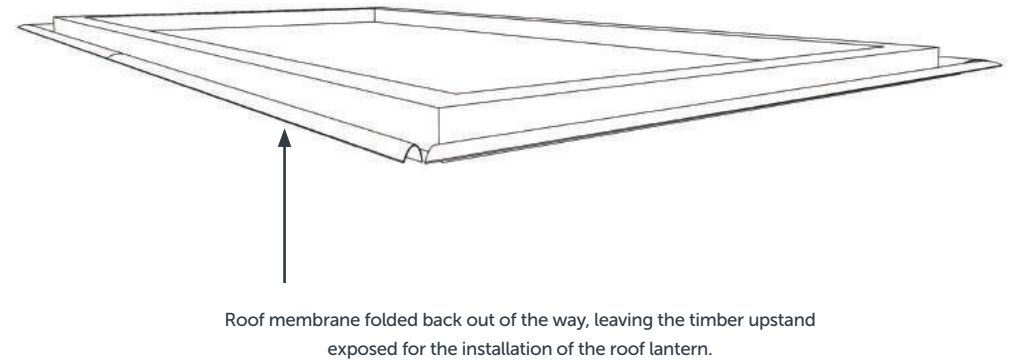

You are now ready to begin the construction of your new roof lantern.

STEP 3 - UPSTAND ASSEMBLY

For most sizes, the built-in, insulated upstand will come ready assembled. But if your roof lantern is larger than 3m x 1.5m you will need to assemble the frame yourself. **If your upstand is pre-assembled, proceed to step 4.**

i) Take two of the corner cleats and insert them into the slots in the frame as shown.

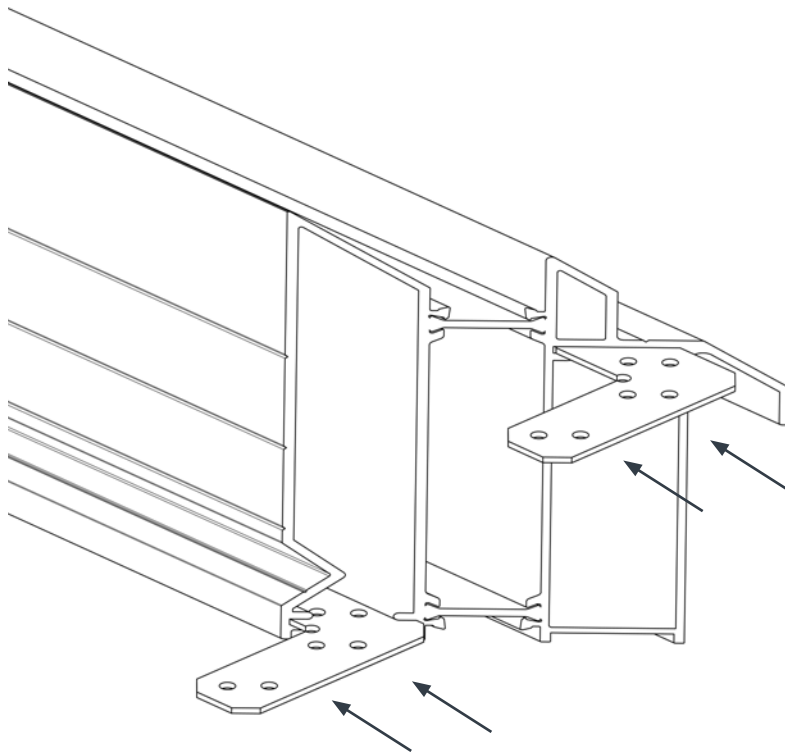

ii) Then take the other ends of the cleats and insert them into the slots of the corresponding piece of the frame. Before you push the two pieces of frame together, make sure that the nut and bolt are placed into the pre-cut hole as shown below.

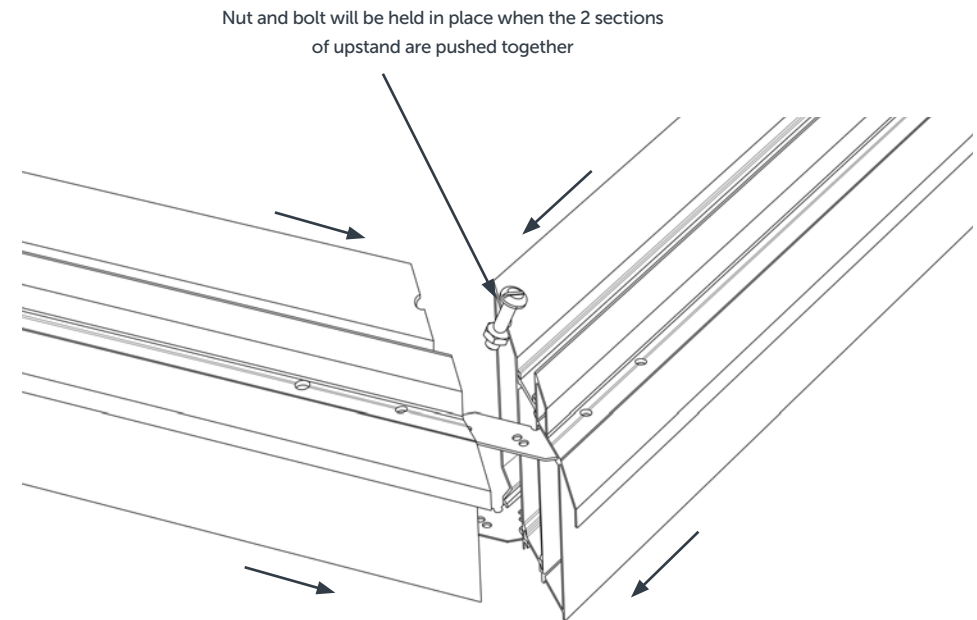

STEP 3 - UPSTAND ASSEMBLY - CONTINUED

iii) Next fasten the frame section together securely using the screws provided through the top of the upstand, through the 4 pre-formed holes. Repeat for all corners.

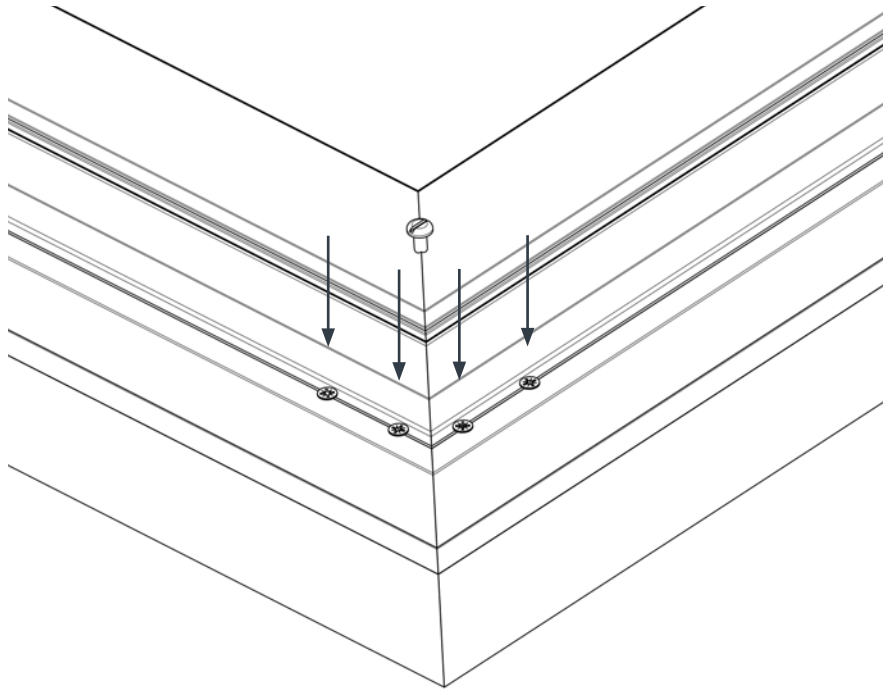

iv) Turn the upstand over and repeat the same process for each corner on the underside of the unit. Fixing the screws through each pre-formed hole. Once complete, the frame should be securely fastened together.

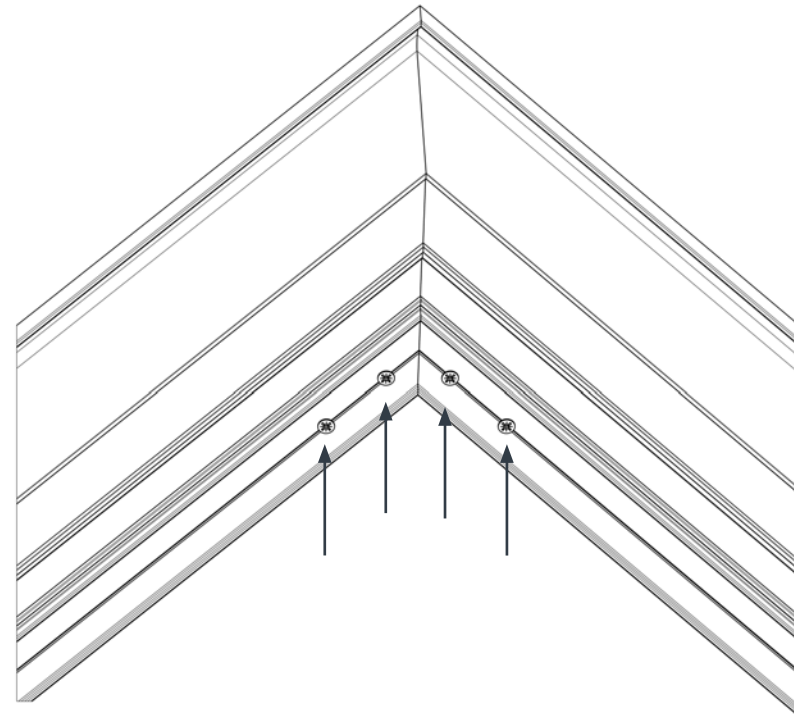

STEP 3.1 - UPSTAND ASSEMBLY FOR UNITS LONGER THAN 3.2M

- i) If your roof lantern exceeds 3.2m in length, the upstand section running the length of the unit will come in 2 parts. You will also receive straight cleats, which are used to join these upstand sections together, end on end.

You will just need to insert the cleats into the slots of the upstand sections as you did with the corner cleats. Following the same process, apply the fixings into the topside of the upstand before turning it over to fix the underside. The below diagram illustrates the use of the straight cleats.

There will be 4 pre-formed screw holes on both the top side and underside of the upstand, as per the corner joints of the upstand

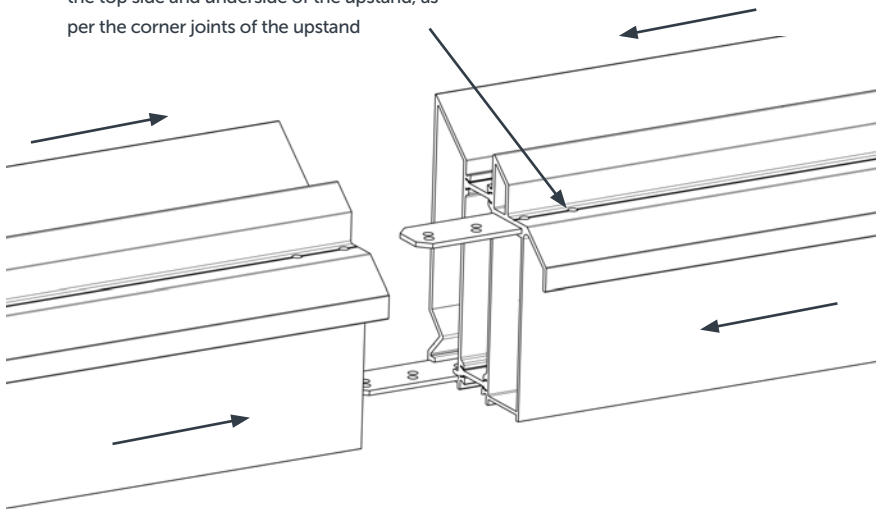

The upstand is now ready to be fixed to your timber kerb.

ROOF MAKER

WORLD CLASS ROOFLIGHTS

Call us: 0116 269 6297

Mon-Fri 9-5pm

STEP 4 - FIXING YOUR UPSTAND TO THE TIMBER KERB

i) Apply a thick bead of silicone all the way around the timber kerb about 20mm from the internal edge. Only use a professional quality silicone adhesive sealant such as Dow Corning 791.

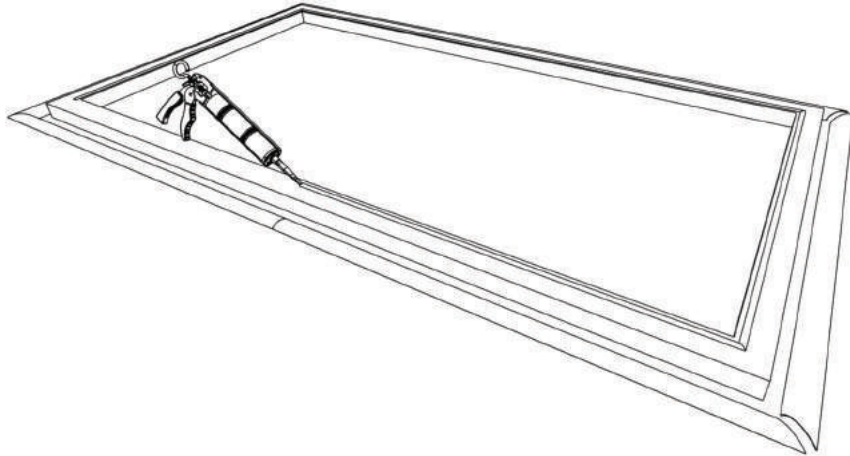

ii) Then carefully place the assembled upstand on to the kerb, ensuring it sits flush with the inner and outer edge of the kerb.

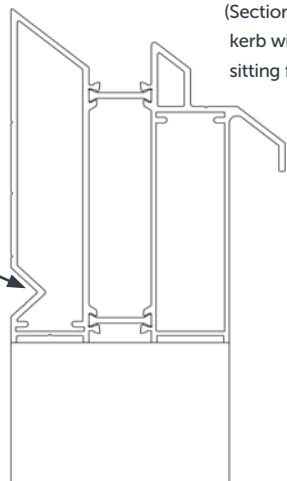

(Section view of your timber kerb with upstand section sitting flush on both sides)

Purpose made groove here to screw-fix the upstand section to your timber kerb (next step)

iii) You now need to secure the upstand to the timber kerb by inserting screws into the purpose made groove as shown, about 100mm from each corner, screwing through the upstand into the timber underneath. You will need to predrill your holes into the aluminium frame using a standard metal drill bit.

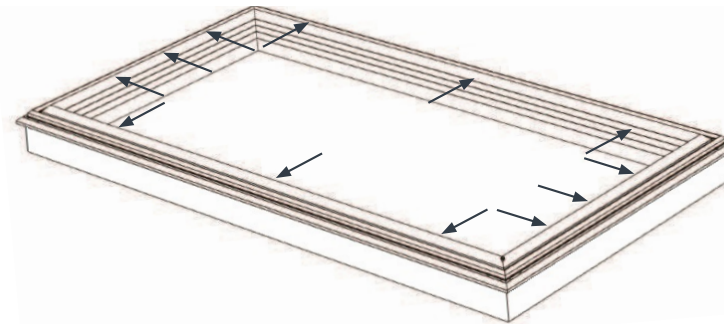
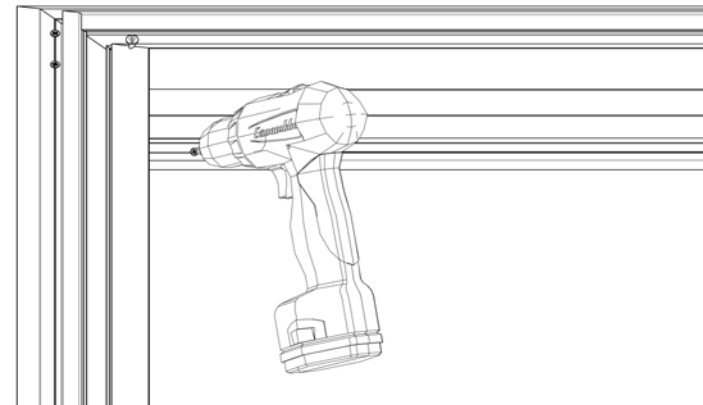

We recommend a minimum of 12 screws - two at each corner, with a further screw in the middle of each side.

For larger lanterns, we recommend inserting additional screws at approx. 500mm intervals.

You are now ready to attach the 4 provided hip bodies to the upstand .

ROOF MAKER

WORLD CLASS ROOFLIGHTS

Call us: 0116 269 6297

Mon-Fri 9-5pm

STEP 5 - FIXING THE HIP BODIES

- i) Bring one of the hip bars into position over the upstand and slide the head of the bolt into the slot of the hip. Please note that the end of the hip bars that have angled corners need to be positioned at the top of the lantern.

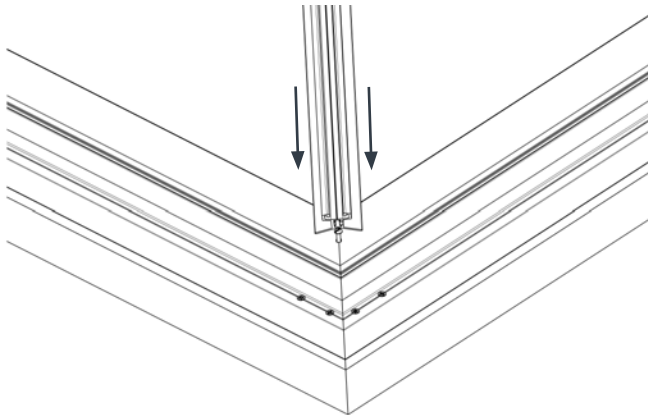

- ii) Now pull the hip body toward you whilst tightening the bolt. This will ensure that the internal nut stays in place whilst tightening. Repeat for all 4 corners.

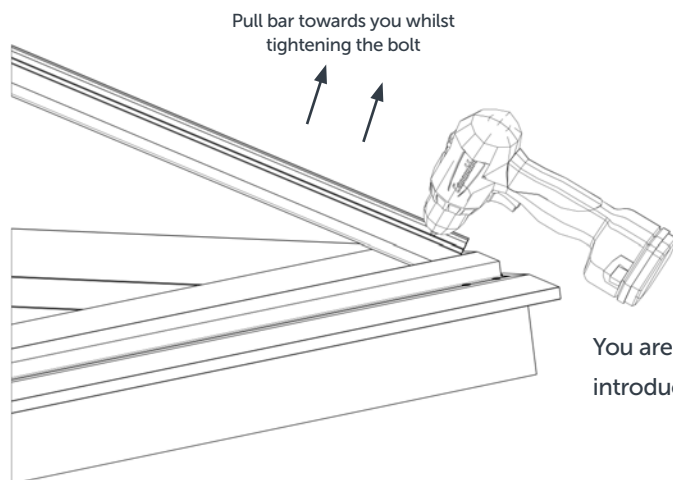

You are now ready to introduce the ridge body.

STEP 6 - FIXING THE RIDGE BODY

- i) The ridge body has blocks located at either end which already house the bolts that will connect to your hip bars. Slide the slotted end of the hip bars over the bolts in the ridge end block. Position the hip bars so they connect with each other in line with the centre of the ridge bar as shown. Tighten the bolts, then repeat at the other end.

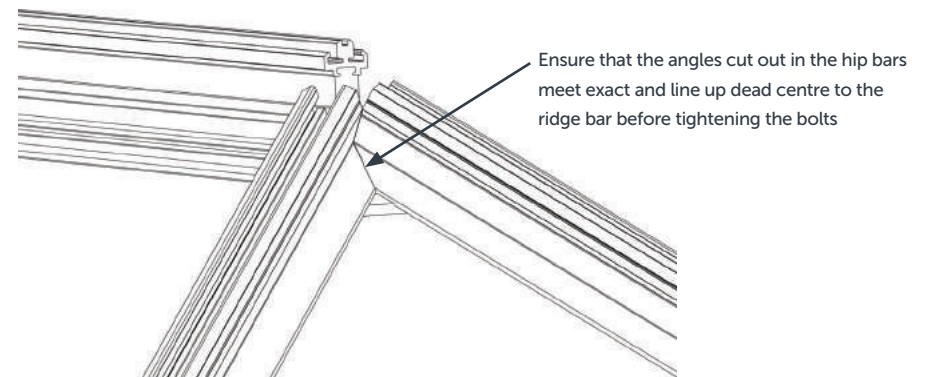
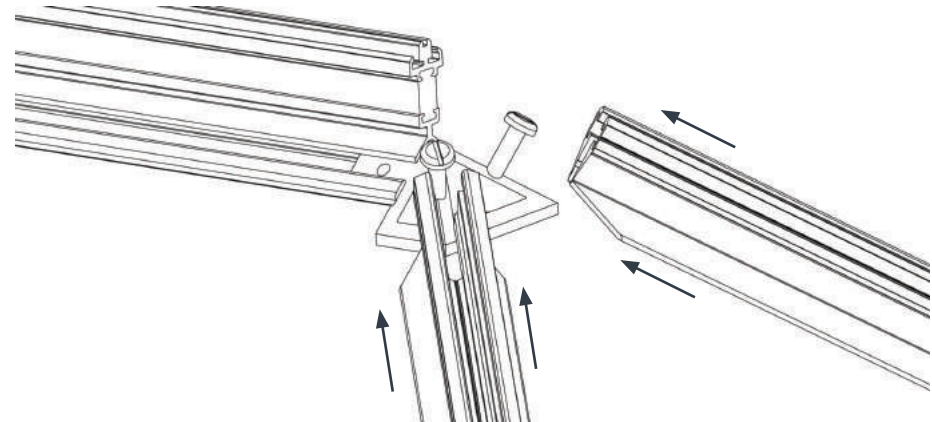

- ii) Now remove the blue protective film from each side of the ridge and hip profiles.

ROOF MAKER

WORLD CLASS ROOFLIGHTS

Call us: 0116 269 6297

Mon-Fri 9-5pm

STEP 7 - POSITIONING YOUR GLAZING PACKERS

- i) Fit the packers at each corner of the upstand, into the groove as shown below. Apply a small spot of silicone either side of the packer to stop them from sliding from side to side.

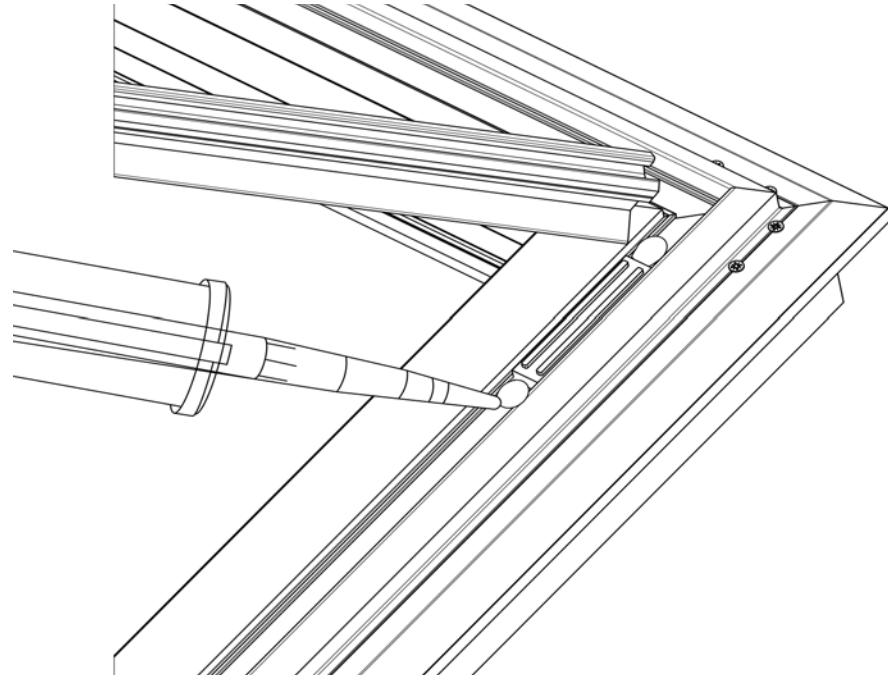

Follow the next steps which show you how many packers you might require and where to position them, dependant on the specification of your roof lantern.

ROOF MAKER

WORLD CLASS ROOFLIGHTS

Call us: 0116 269 6297

Mon-Fri 9-5pm

STEP 8 - POSITIONING YOUR GLAZING PACKERS

- ii) You may have opted to just have a single pane of glass on the opposite side to the vent, in which case only 2 packers will be required on this side to sit the glass onto.

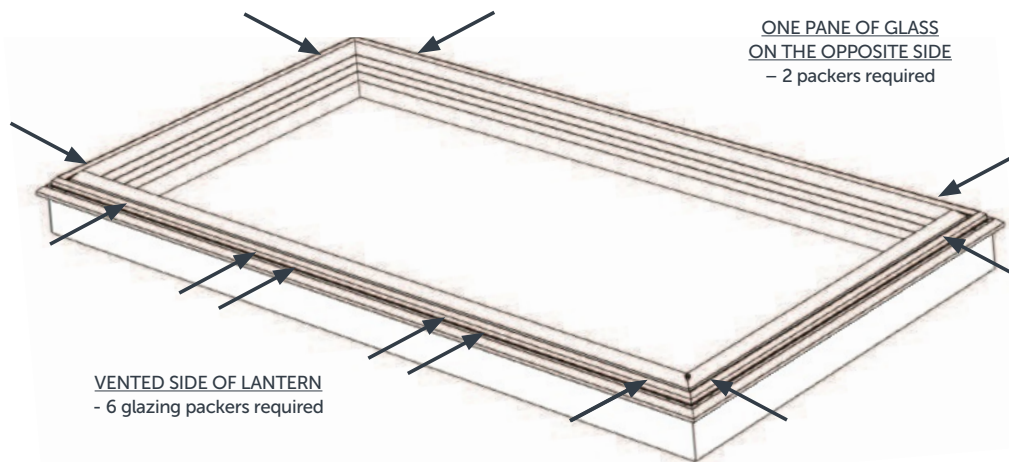

Overhead view of lantern configuration

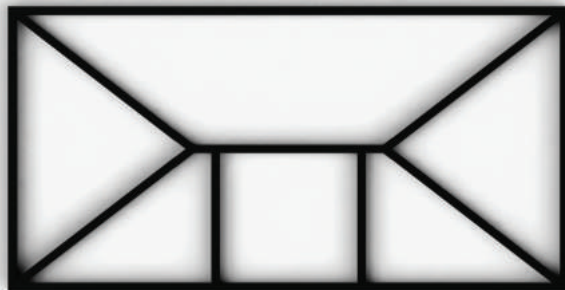

STEP 8.1 - POSITIONING YOUR GLAZING PACKERS

- i) If you have opted to 'mirror' the vent on the opposite side of the lantern with T-bars, you will need to employ the same principle in having 2 packers per glass panel (6 in total) for the mirrored side of your lantern too.
- ii) If you have opted to have a vent on both sides of the lantern, the same principle applies.

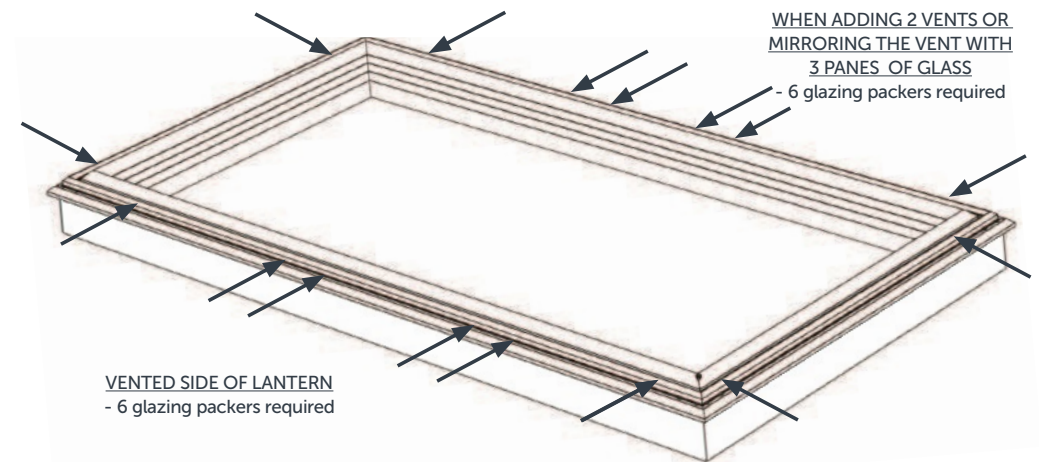

Overhead view of lantern configuration

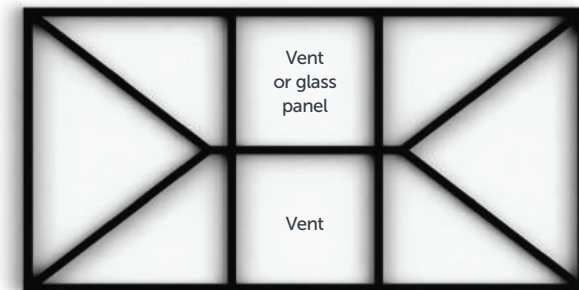

ROOF MAKER

WORLD CLASS ROOFLIGHTS

Call us: 0116 269 6297

Mon-Fri 9-5pm

STEP 8.2 - POSITIONING YOUR GLAZING PACKERS – FOR TRIPLE GLAZED LANTERNS WITH A WIDTH BETWEEN 1800MM-2000MM

i) When your lantern is triple glazed and the width measures between 1800mm and 2000mm, the end 'triangular' panes of glass on your lantern will also have a split down the centre.

In this scenario, you will also need to use 2 packers per pane of glass across the width of the lantern on both sides, as the below arrows indicate on the upstand diagram.

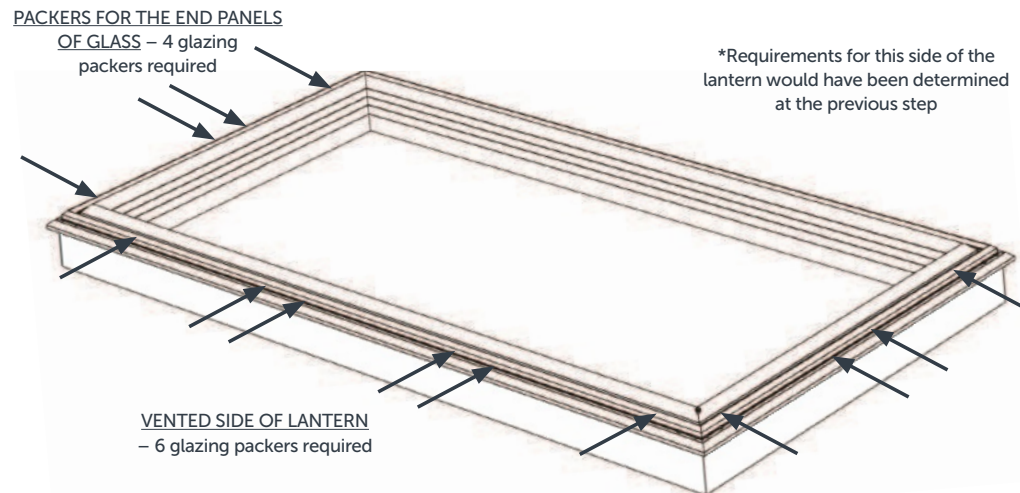

The next stage is to insert the vent housing and glass sections. The frame is designed so these will fit easily and neatly into place, but care needs to be taken as these are the heaviest components of your roof lantern.

STEP 9 - PEELING BACK THE PROTECTIVE FILM

i) Before you introduce your glass panels to the unit, peel back the first approx. 5cm of the green protective film from the glazing tape that has been pre-applied to your ridge and hip bars. Do this at both ends of the hips and ridge bar as shown. Ensure that this excess film will be accessible from the inside of the roof lantern when the glass is positioned.

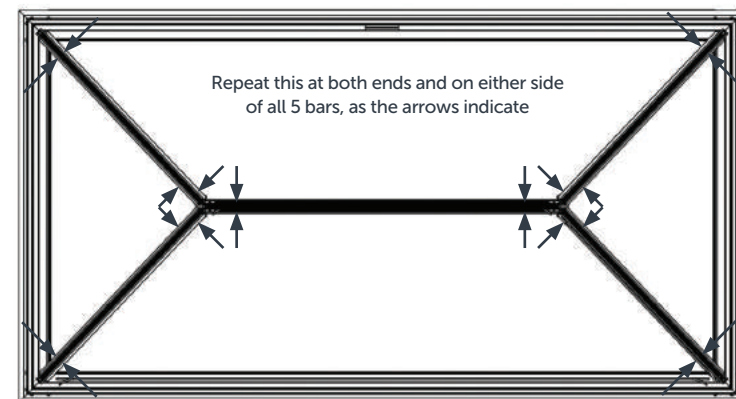
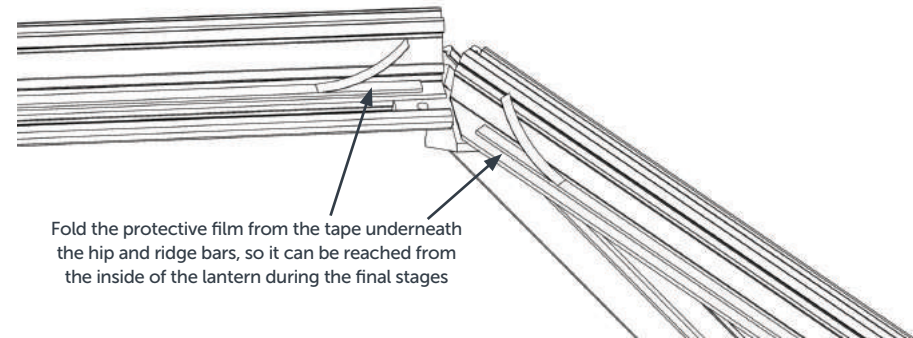

ROOF MAKER

WORLD CLASS ROOFLIGHTS

Call us: 0116 269 6297

Mon-Fri 9-5pm

STEP 10 - ASSEMBLING THE VENTED SIDE OF YOUR LANTERN

- i) Take the 2 small panels of glass that go either side of the vent section, and position them correctly into the inside grooves of the packers, making sure that they are pushed up against both hip bars as much as possible.

Ensure that you insert the glass in to the inside groove of the packer to ensure that the glass sits flush onto the frame. Failure to do this will effect the fitting of your glazing bar cappings later in the installation

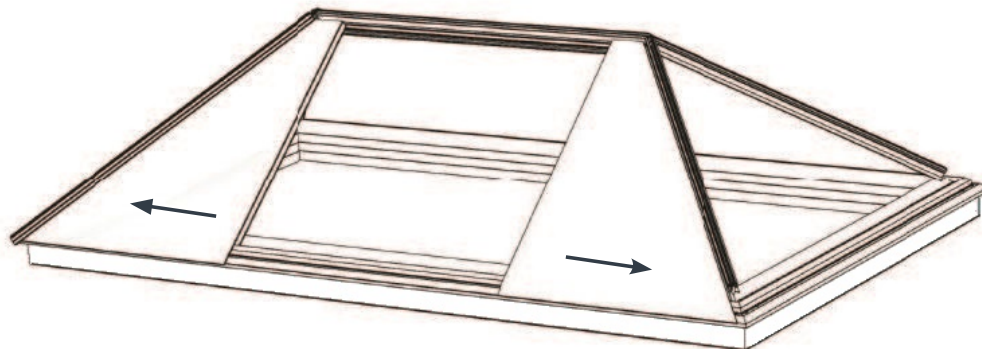
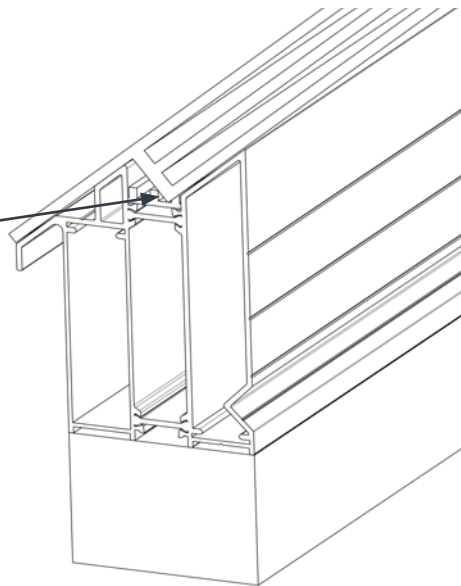

STEP 11 - PREPARING YOUR INNER T-BARS

For lanterns with one vent and no further splits in the remainder of the unit

- i) You will have a minimum of 4 lengths of T-Bar, 2 of which will be for the internal side of the lantern and 2 for the outer.
- ii) The longer T-Bars have a section of the central spine removed and are one of the final stages of constructing the roof lantern. The 2 shorter bars will be what you require at this stage.

For lanterns with more than 1 vent, additional splits in the glass or where the triangular end panels of glass are split (triple glazed units measuring between 1800mm and 2000mm in width)

- i) You will have a minimum of 8 lengths of T-Bar, 4 of which will be for the internal side of the lantern and 4 for the outer. This may increase dependant on the number of splits you have in the unit.
- ii) If you have a split in the triangular end panels of glass, the relevant T-bars will be cut into an angle at one end. The angled end sits at the top of the unit where the 2 hip bars meet. The below diagram shows this.

T-Bar with angled ends for use on the end triangular panes of glass

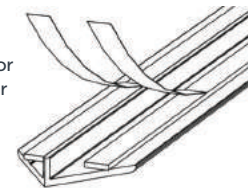

T-Bar with flat ends for use on the longer panes of glass



- iii) The longer T-Bars have a section of the central spine removed and are one of the final stages of constructing the roof lantern. The shorter T-bar sections will be what you require at this stage.

ROOF MAKER

WORLD CLASS ROOFLIGHTS

Call us: 0116 269 6297

Mon-Fri 9-5pm

STEP 11.1 - PREPARING YOUR INNER T-BAR

- i) Take 2 shorter inner T-Bar sections with the flat cut ends and peel the first 5cm of green protective film back from both ends. Fold this excess film around the back so that it can be reached from the inside of the lantern when completed.

Fold the protective film around the back of the T-Bar so it can be located from the inside of the lantern and removed when the assembly is complete

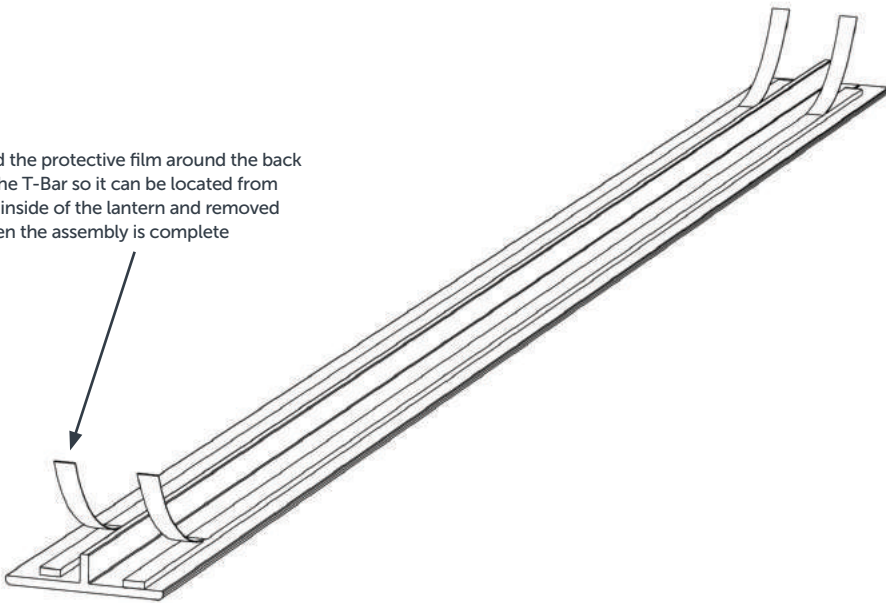

You are now ready to position your T-Bar

STEP 12 - POSITIONING THE FIRST INNER T-BAR

- i) Position the T-Bar onto the frame to the side of the first pane of glass. This will rest flush on the ridge bar at the top and on the angled face of the upstand at the bottom as shown. Carefully feed the bar behind your set panel of glass, but do not allow the glass to touch the central spine of your T-Bar.

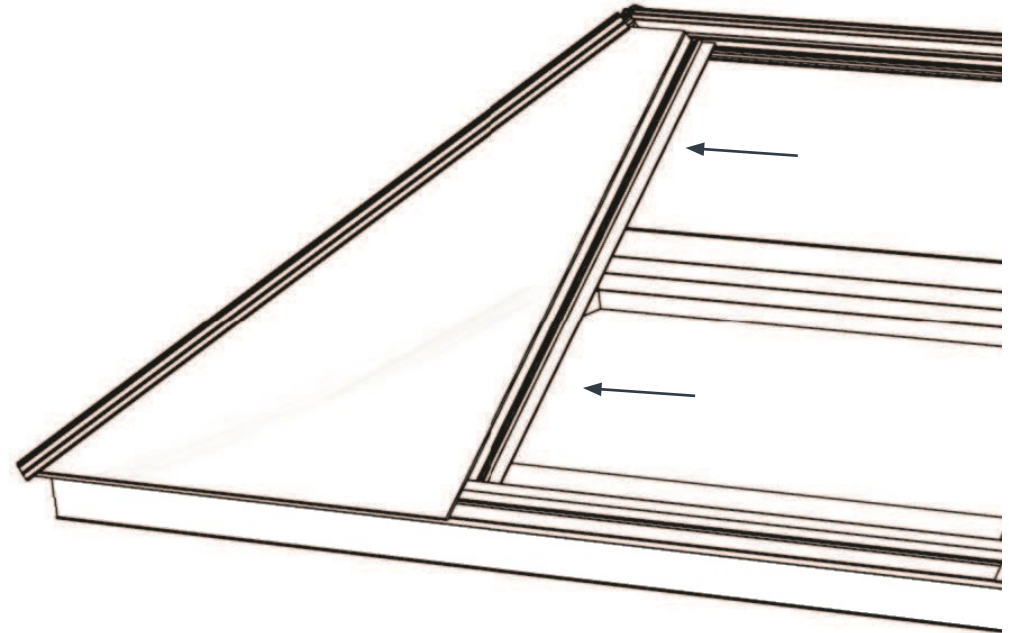

- ii) Repeat this process for the other pane of glass.

ROOF MAKER

WORLD CLASS ROOFLIGHTS

Call us: 0116 269 6297

Mon-Fri 9-5pm

STEP 13 - INTRODUCING THE VENT HOUSING AND GLAZED LID

- i) You can now bring your vent housing in, which is the non-glazed section, and position it centrally between the 2 sections of T-Bar. Ensure that the central spines of the T-Bars as you did with the glass.

Your chosen opening mechanism will be positioned at the bottom and will be on the inside of the lantern.

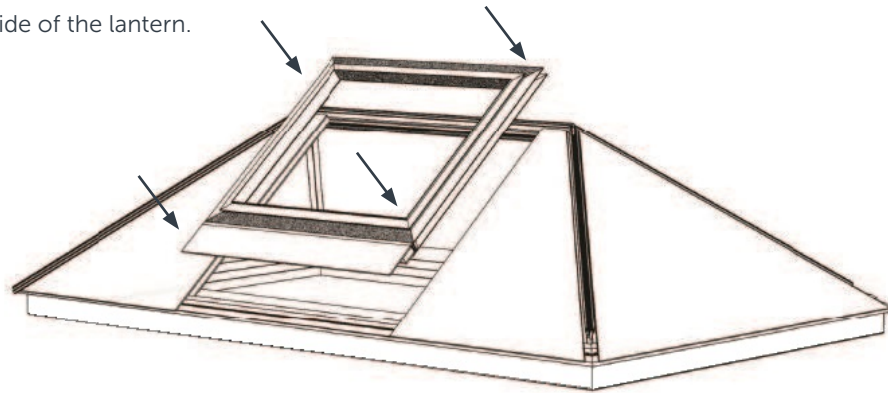

- ii) Hook the lid of the vent, which is the glazed section of the vent, onto the top detachable hinge of the vent housing. Your chosen mechanism will be positioned at the bottom of the unit, on the inside of the lantern.

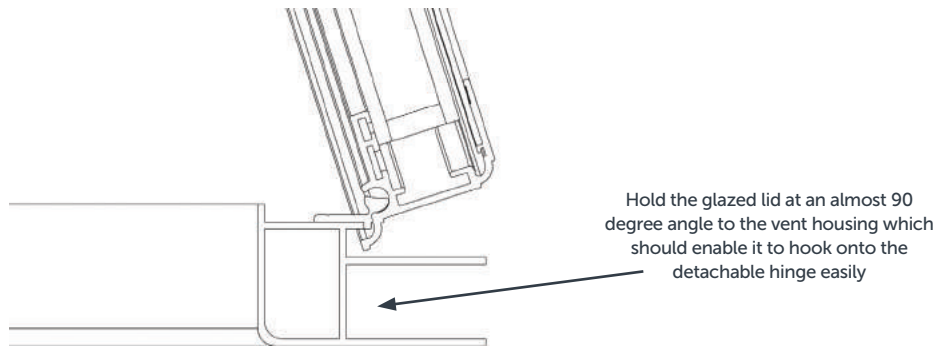

STEP 14 - PREPARING YOUR PLASTIC RIDGE CARRIER

- i) Prepare your ridge carrier by cutting off the corners with a hacksaw, set in from the ends of your ridge carrier by approx. 20mm as the diagram shows. Do this at both ends, making 4 small cuts.

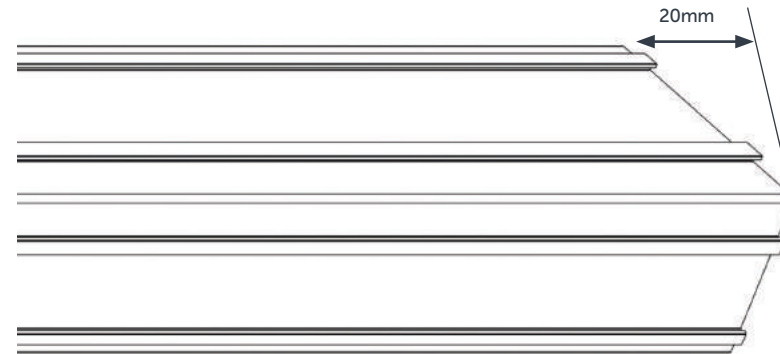

- ii) The ends of the ridge carrier might be slightly rough or frayed after doing this, which will effect the ease of sliding your ridge top cap into place during the next step. If this is the case, we advise that you gently shave the ends with a stanley knife, to create a smoother surface.

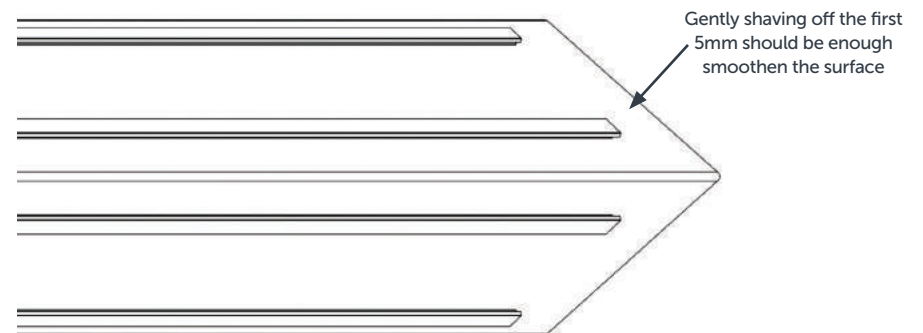

STEP 14 - PREPARING YOUR PLASTIC RIDGE CARRIER - CONTINUED

iii) Due to the vent, you now need to make another cut. Position your ridge carrier without tapping it to fix it, positioning it as close to its eventual position as possible, and mark where the outside edges of the T-Bars will fall on the vented side.

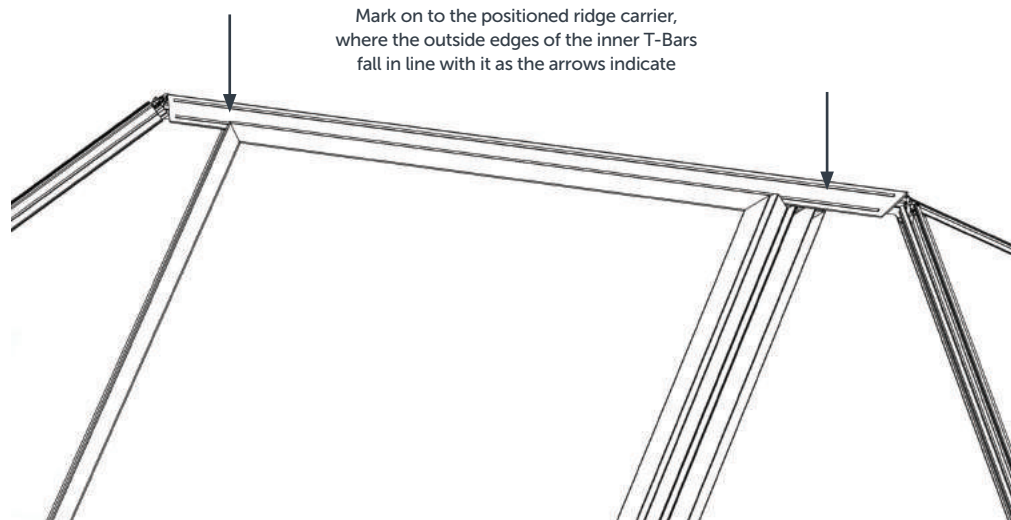

iv) You then need to take 5mm off the ridge carrier, between your 2 marks. We recommend that you use a hacksaw to get to the 5mm depth required, followed by using a sharp Stanley knife to run it along the outside of the hip runner, located near to the outside edge of the vented side. Once you have scored along this line, using the runner as a guide, this small section should break away easily.

Only repeat this cut out to the other side of the ridge carrier if there is a vent positioned both sides of the lantern. If you have mirrored the vent with T-Bars or have a single pane of glass opposite, this will not be required. Set the prepared ridge carrier to one side for later.

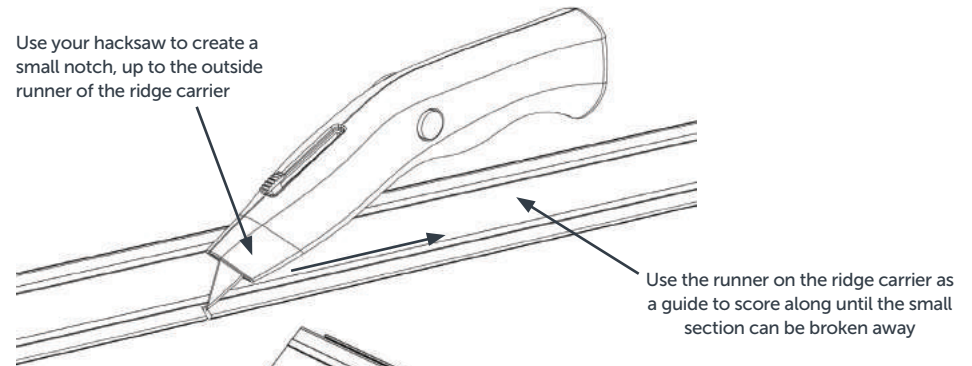

Your ridge carrier should look like this when you have completed the cut-out.

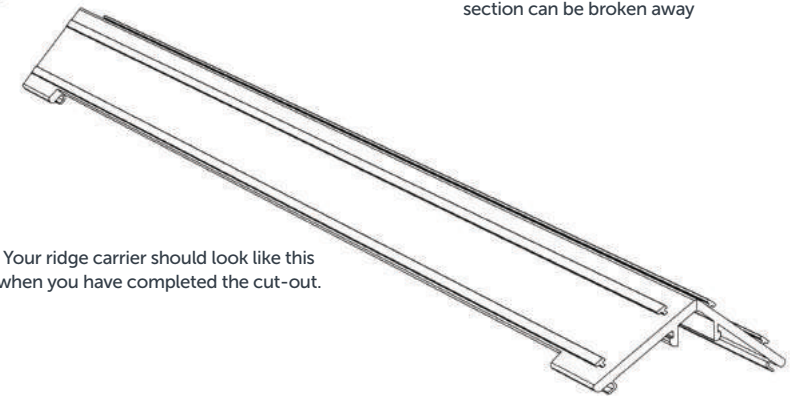

STEP 15 - PROCEED TO GLAZE THE OPPOSITE SIDE OF THE UNIT

i) Glaze the opposite side of the unit to the vent. If you have a vent in the opposite side, it will be the same process as seen in the previous steps.

If you have mirrored the vents with splits in the glass, start by introducing the outer 2 panes of glass, then your T-bars and lastly your central pane of glass, resembling the order you work in when glazing the vented side of the unit. Ensure that the same principles are followed in regards to using the inside groove of the glazing packers and do not allow the glass to touch the central spines of the T-Bar.

If you have a single pane of glass on the opposite side to the vent, you just need to carefully position the glass into the unit, ensuring that it goes into the inside grooves of the packers.

STEP 16 - FINAL STAGES OF GLAZING

i) You can now fix the 2 triangular end panes of glass. If these are singular panes, you just need to carefully position the glass into the unit, ensuring that it goes into the inside grooves of the packers.

If the end triangular panes of glass have been split into 2 sections, follow the same principle that you followed when adding a vent, by positioning the first pane of glass and ensuring that it is positioned as tight against the hip bar as possible.

Following this, take your inner shorter T-Bar which has the angular cut at one end, ensuring that this end is positioned at the top. Before feeding it behind the set pane of glass, ensure that you have folded the first 5cm of protective film from the glazing tape, at either end of the bar and both sides of the central spine.

Following the insertion of the T-bar, insert the other pane of glass and ensure the T-Bar sits central between the 2 panes.

Repeat this on the opposite side of the lantern.

ROOF MAKER

WORLD CLASS ROOFLIGHTS

Call us: 0116 269 6297

Mon-Fri 9-5pm

STEP 17 - APPLYING SILICONE

i) Ensuring that you use the provided Dow Corning 791 silicone, apply a generous amount of silicone into the central groove at the top and bottom of each of the hip profiles, running about 100mm from each end of the bars.

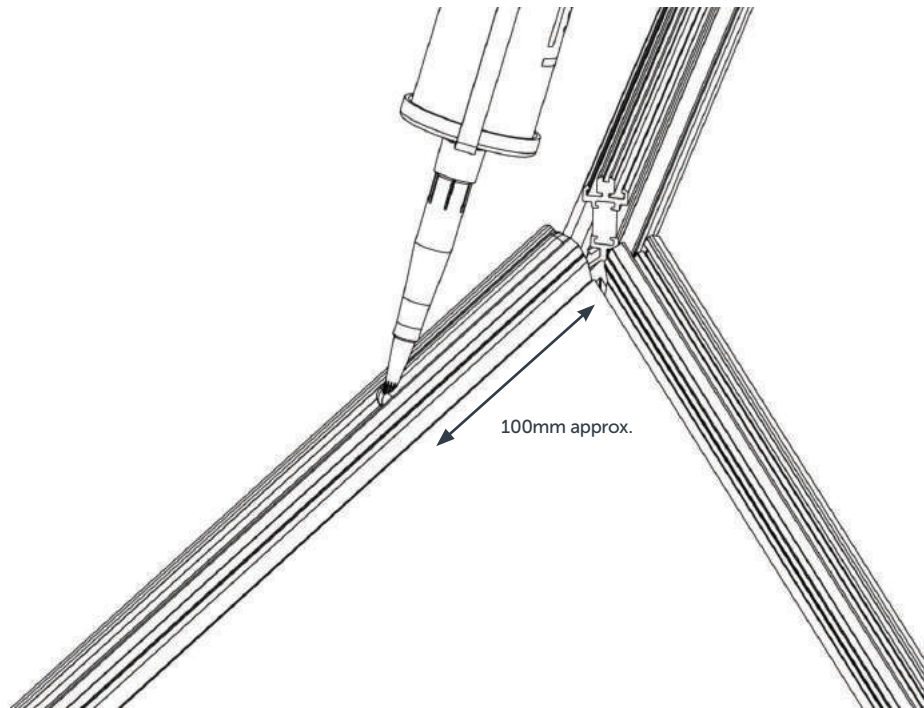

ii) Next run silicone between all the glass panels and frames, on either side of the hip and ridge bars. Only 100mm of silicone is required running from each end of the hip bars. For the ridge bar, run silicone the full length on both sides.

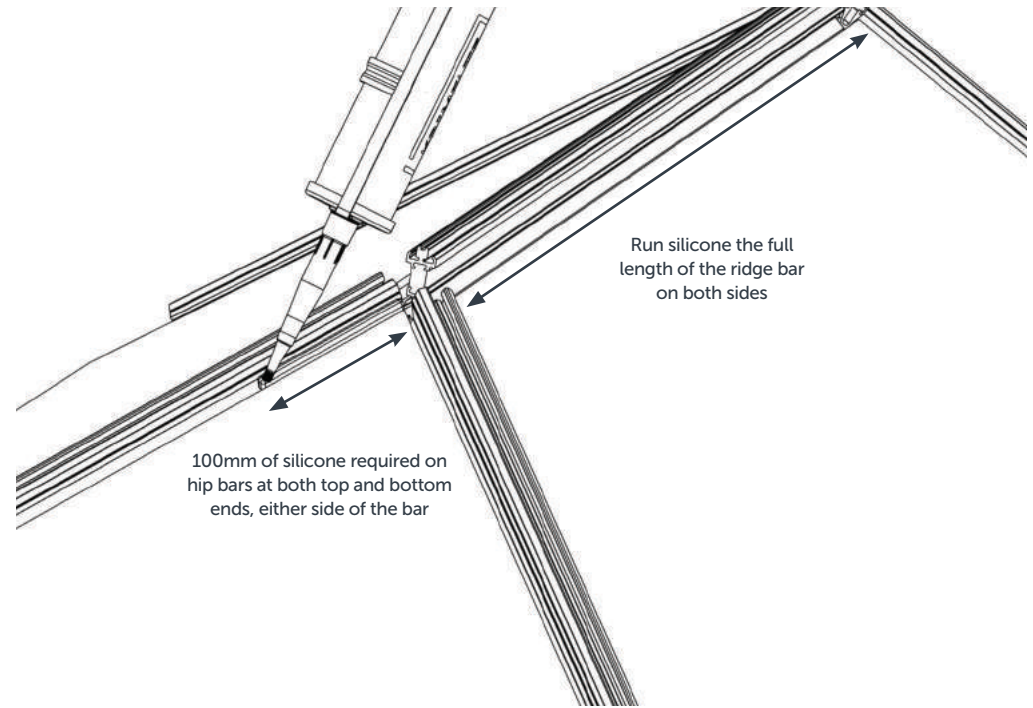

ROOF MAKER

WORLD CLASS ROOFLIGHTS

Call us: 0116 269 6297

Mon-Fri 9-5pm

STEP 18 - INTRODUCING THE HIP CARRIERS AND HIP TOP CAPS

i) Prepare your hip carriers and aluminium top caps by sliding them together with the angled part of both pieces being positioned at the same end. These pieces are angled where they will meet at the ridge bar when applied. Stagger the hip carrier so that 100mm is sticking out at the top, as you cannot slide the hip caps up into position until the ridge carrier and top cap is fitted.

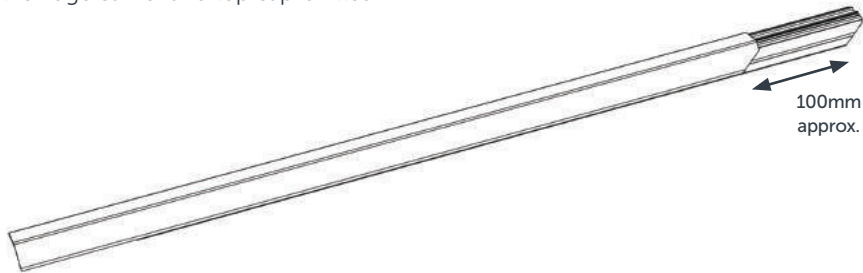

ii) Gently tap the hip carriers and top caps onto the hip bars with your rubber mallet.

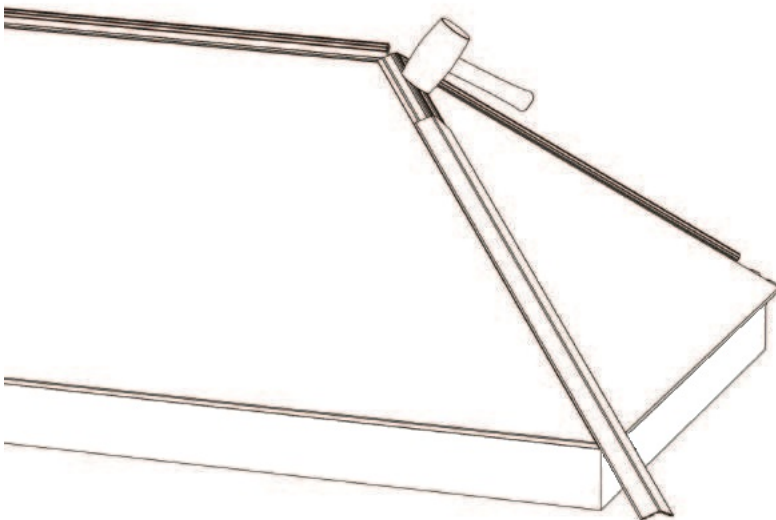

iii) Slide the hip carriers up the hip bar, ensuring that the angled cut-outs line up perfectly and are positioned dead centre to the ridge bar.

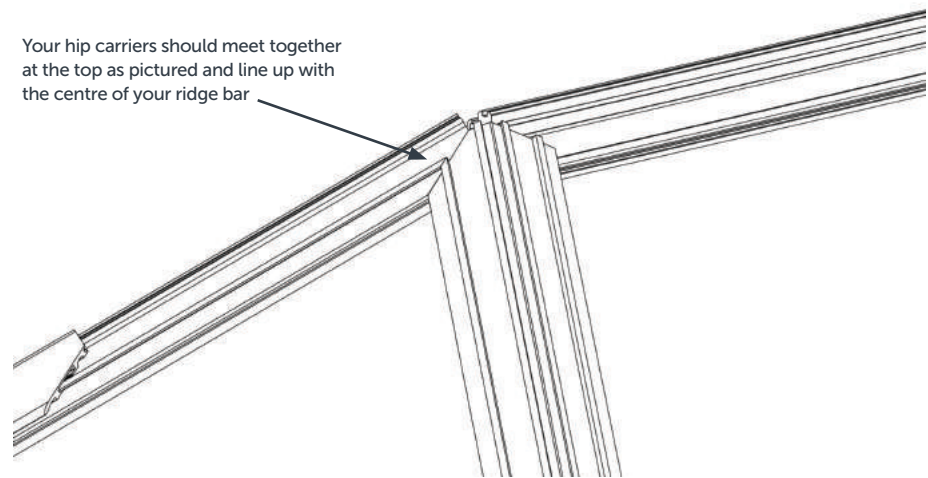

iv) Repeat this process on the other end of the roof lantern.

STEP 19 - INTRODUCING THE RIDGE CARRIER AND RIDGE TOP CAP

i) When prepared, bring in your ridge carrier, gently tapping it into place carefully by hand or with your rubber mallet. Ensure it is centred perfectly by checking both ends.



ii) Then slide your ridge top cap in from one end onto the ridge carrier, again, ensuring that it is perfectly centred by checking both ends as shown.

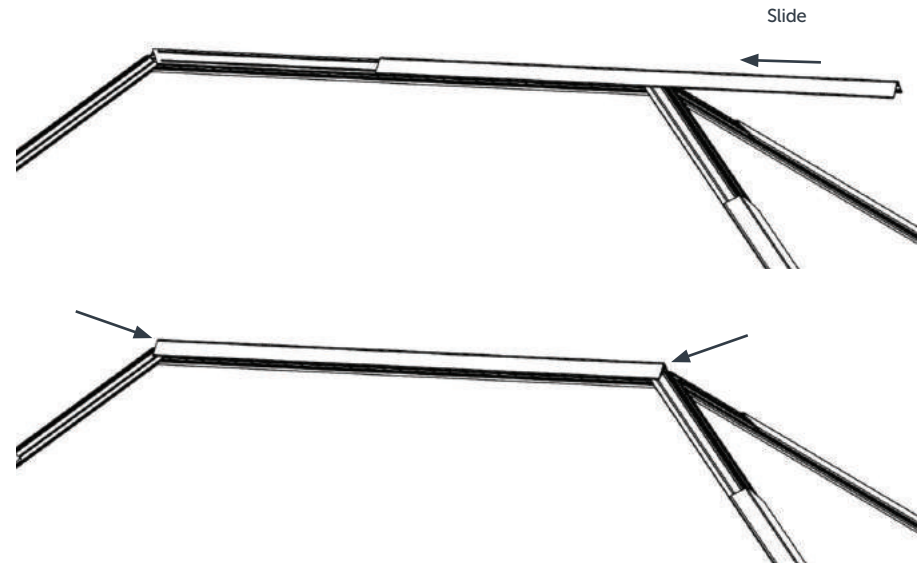

STEP 20 - POSITION THE HIP TOP CAPS

i) You can now slide the hip top caps into position so they meet evenly at the top centre, as you did with the hip carriers. You must ensure that the hips sit underneath the ridge top cap as shown. Repeat on the other side of the roof lantern.

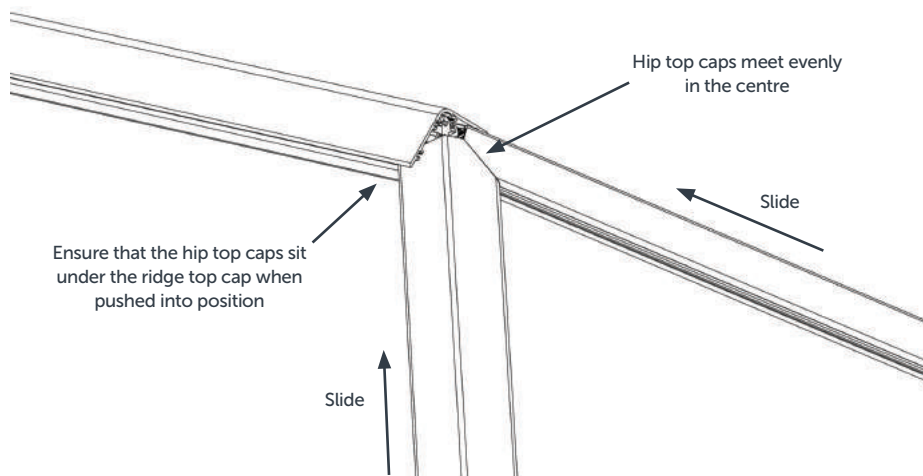

ii) If the plastic hip carrier is protruding from the bottom of the hip bars, use a hacksaw to carefully remove the excess, being careful not to damage the aluminium hip caps. Repeat at each corner if necessary.

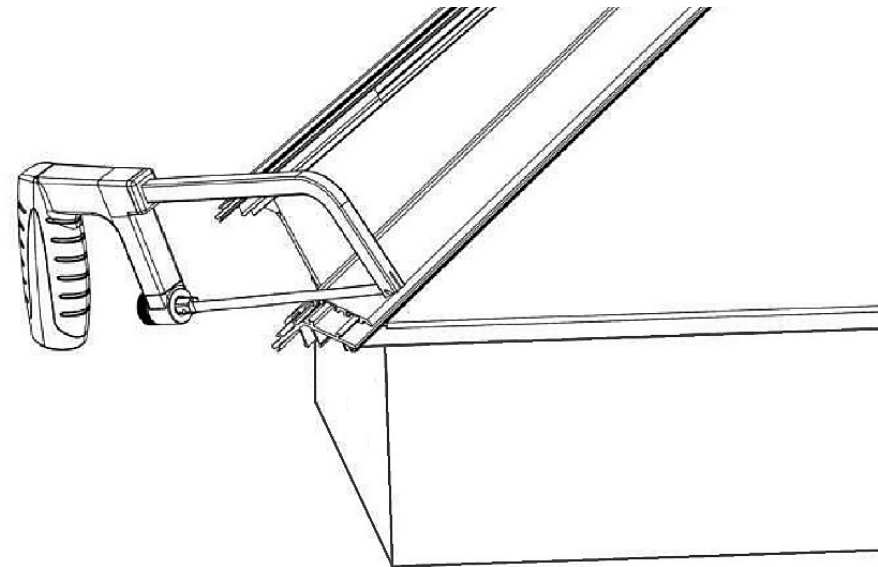

Next, you are ready to fix the 4 provided hip end caps to the bottom of your hip bars.

ROOF MAKER

WORLD CLASS ROOFLIGHTS

Call us: 0116 269 6297

Mon-Fri 9-5pm

STEP 21 - FITTING THE HIP AND RIDGE END CAPS

i) Using a screw gun set at a low gear, attach the end caps as shown, being careful not to overtighten them. Repeat at all 4 corners of the lantern.

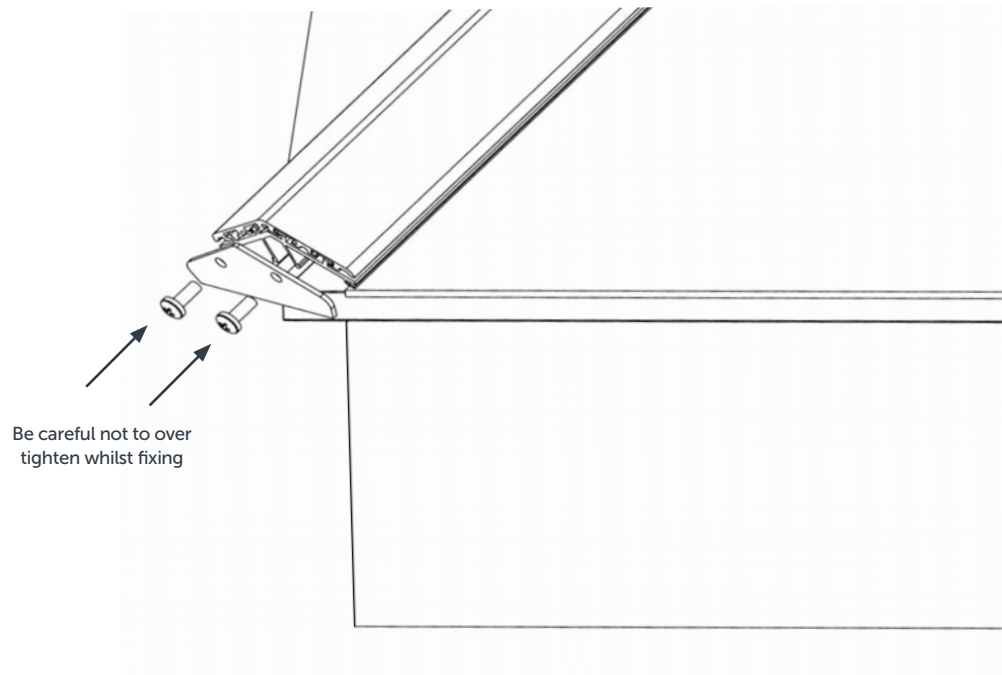

ii) It is now time to fit the two ridge end caps. Fill the space between the end of the ridge cover and the hip caps generously with silicone as shown and apply the two end caps.

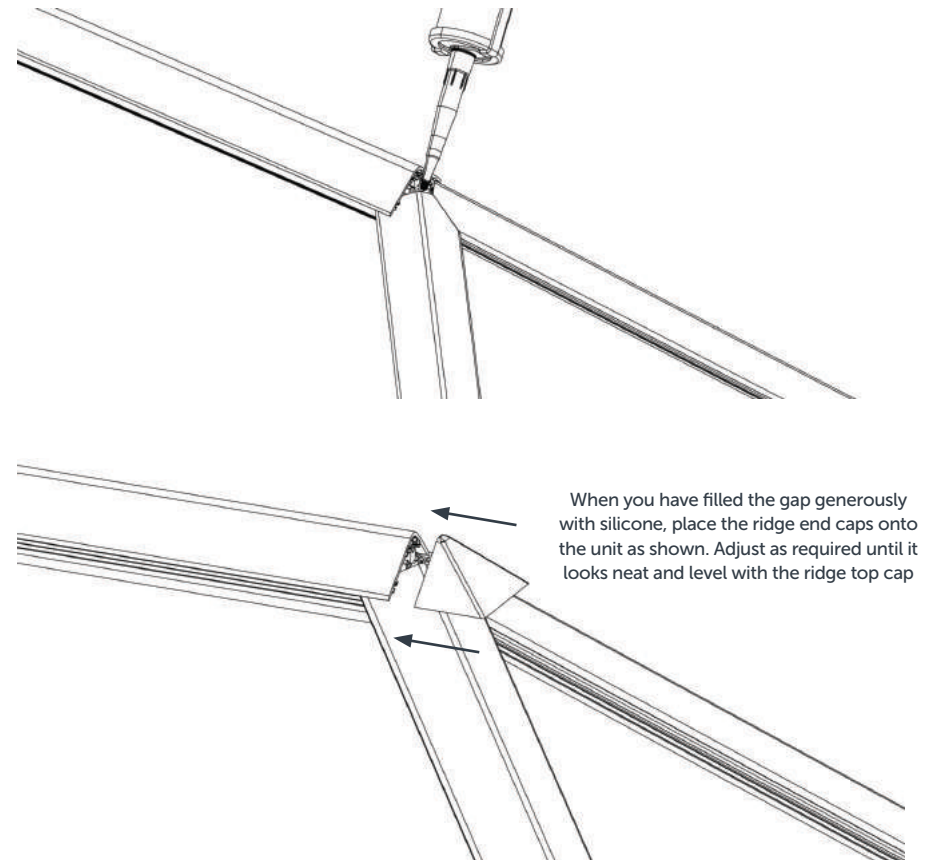

STEP 22 - APPLYING THE OUTER SECTIONS OF THE T-BARS

i) Generously fill the gaps between the 2 glass and vent housing panels as shown with the silicone provided.

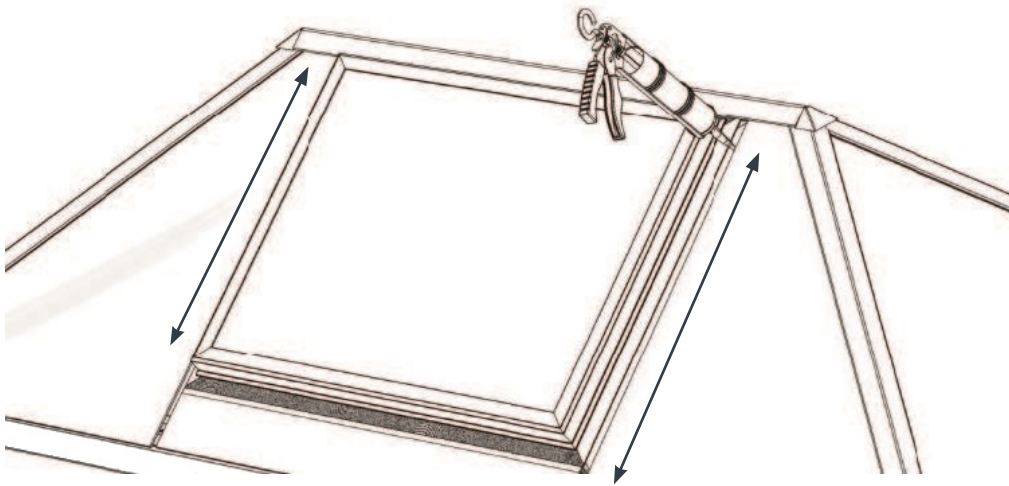

ii) Remove all of the green protective film from of glazing tape on both sides of the bar and push the T-bar into the silicone to complete the seal, ensuring the top of the T-bar is fitted tightly to the ridge top cap. Press down firmly to ensure the glazing tape sticks to the surface of the glass and vent housing.

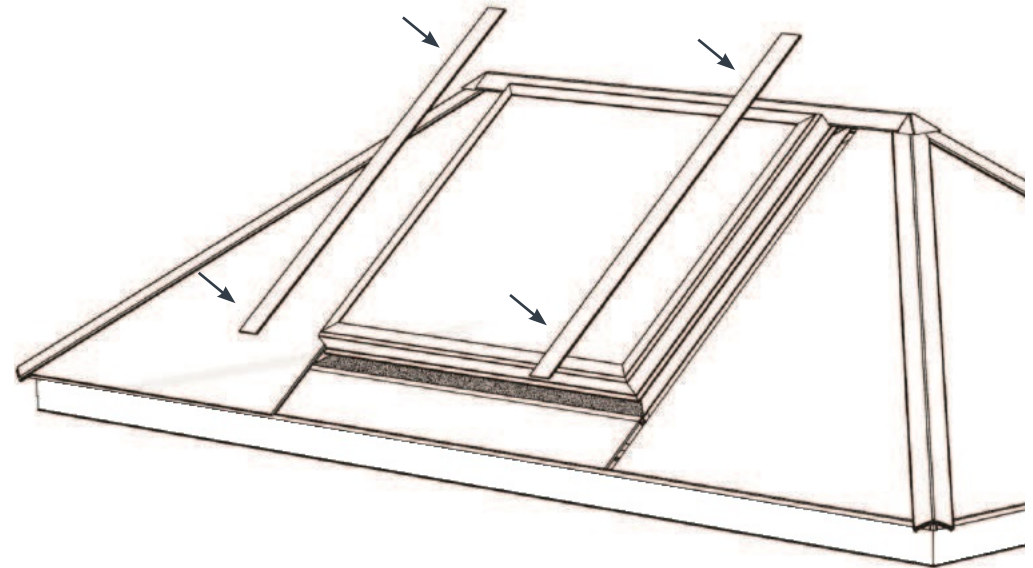

Your outer T-Bars will be factory prepared with glazing tape, either side of the central spines. The ends of the T-Bars that have the central spine notched out will be positioned at the bottom. There will be 2 layers of glazing tape on one side of the bar and only one layer on the other side. The side with 2 layers of glazing tape must go to the 'glass side' and the single layer will be the side that covers the vent housing.

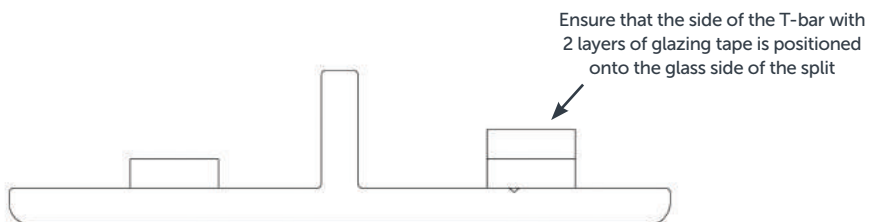

STEP 22 - APPLYING THE OUTER SECTIONS OF THE T-BARS - CONTINUED

iii) Repeat this process if you have a vent on the opposite side of the unit.

If you have mirrored the vents with glazing splits, follow the same process but be aware that the T-Bars will be slightly different and only have one layer of glazing tape on both sides of the central spine.

If the end triangular pane is split, again, it is the same process, but do ensure that you use the correct T-Bars that have the angular cut ends. When you push it in to the join, make sure that you push the bar up to the 2 hip top caps as much as possible.

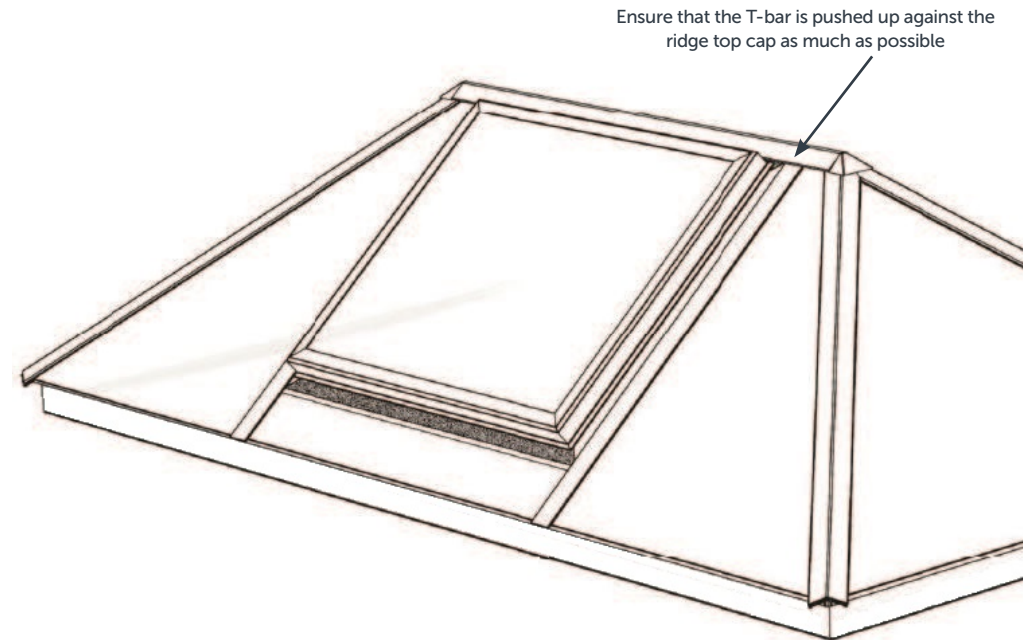

STEP 23 - FINAL STAGE OF ASSEMBLY – SEALING THE UNDERSIDE OF THE GLASS PANELS

i) Your Slimline® roof lantern assembly is now nearly complete. All that remains is to seal the underside of the bottom edge of the glass with silicone, ensuring that the bottom edge of the glass is sealed to the drip lip of the upstand. Repeat this on all 4 sides. Wipe away any excess silicone with a damp cloth.

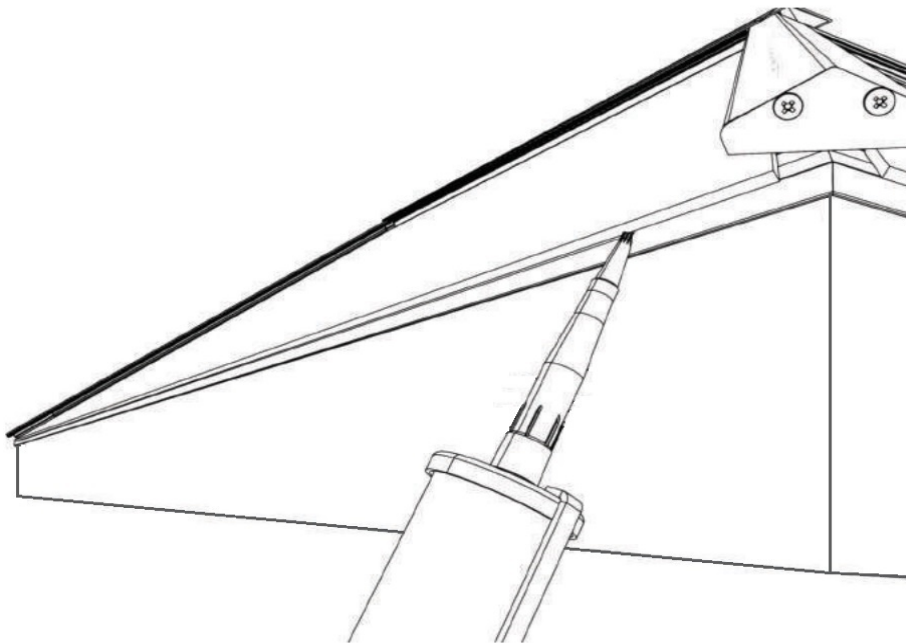

ii) From the inside of the lantern, gently remove all of the protective film from the glazing tape on the hip and ridge bars.

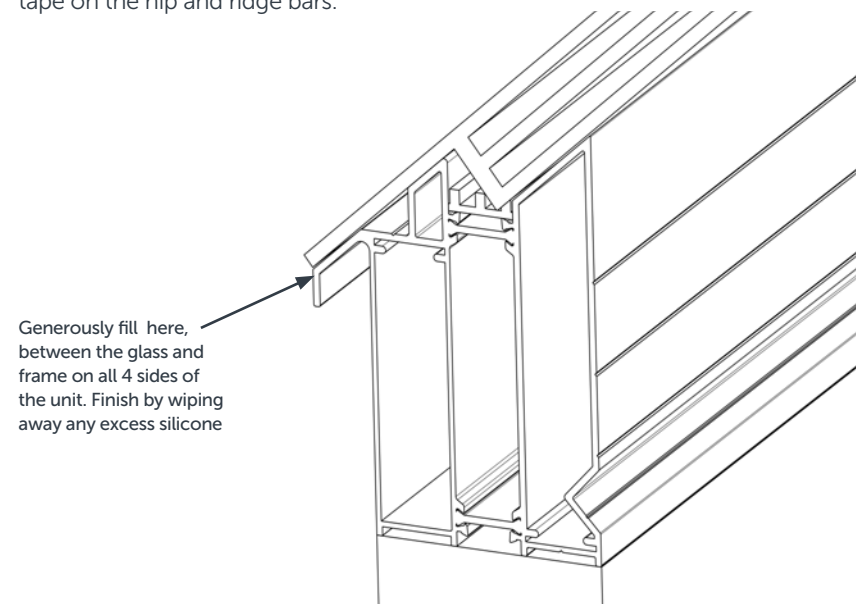

The assembly of your Slimline® lantern is now complete. You are now ready to flash the upstand with your chosen roof membrane.

Your chosen opening mechanism is pre-attached to your vent housing and vent. There will be a small pin attached to the mechanism which allows you to attach either the chain or screw jack to the lid of the vent. If you have opted for an electronic opening vent, ensure a qualified electrician carries out the wiring aspect of the installation.

The wiring guides for both the rocker switch-controlled vents and climate controlled with rain sensor can be found on pages 29-31 of this document.

STEP 24.1 - FLASHING GUIDELINES - (sheet membrane)

i) Ensure the roof membrane is tucked right under the dedicated drip lip that sits just under the glass. This is important as it acts as the final weathering stage to avoid water ingress in this area. Take a look at the diagram below which illustrates this detail.

If using a torch on felt, we recommend that you cut your membrane to the correct size, fold back and pre-heat with your heat gun. Only then should you apply it to the side of the unit. This will prevent you from damaging the unit by applying heat directly.

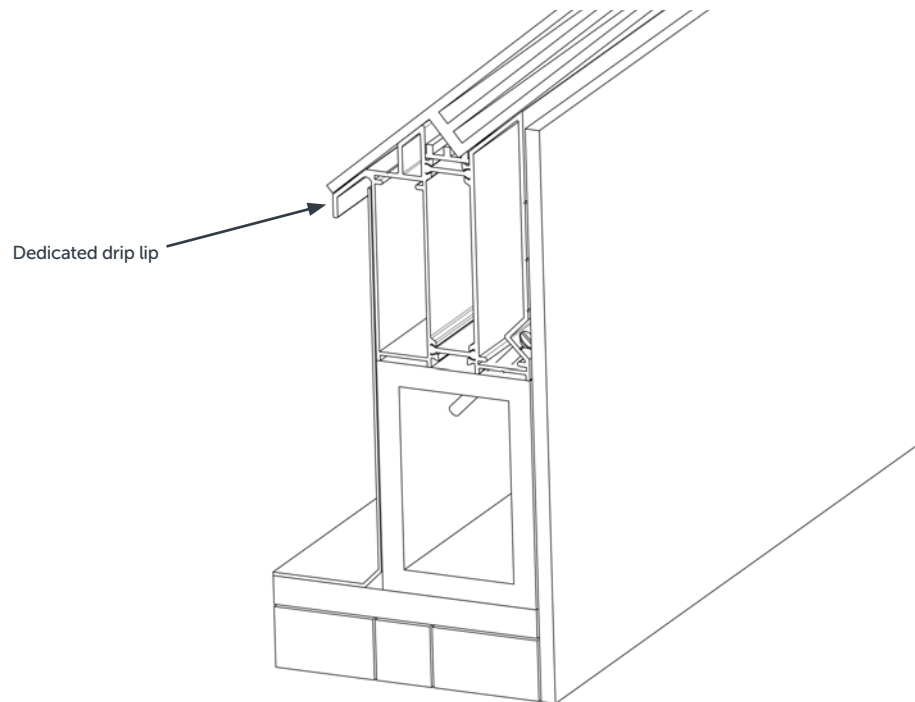

STEP 24.2 - FLASHING GUIDELINES - (GRP membrane)

i) If using GRP to finish the roof, you should silicone bond a 4mm plywood border around the upstand and kerb. Screw fix this into the timber kerb if you wish to make it more secure. This will provide a more suitable surface for the GRP to adhere to. Ensure that this goes right up underneath the drip lip as the below image shows. Also, ensure that the GRP layer is applied right up to and underneath the drip lip.

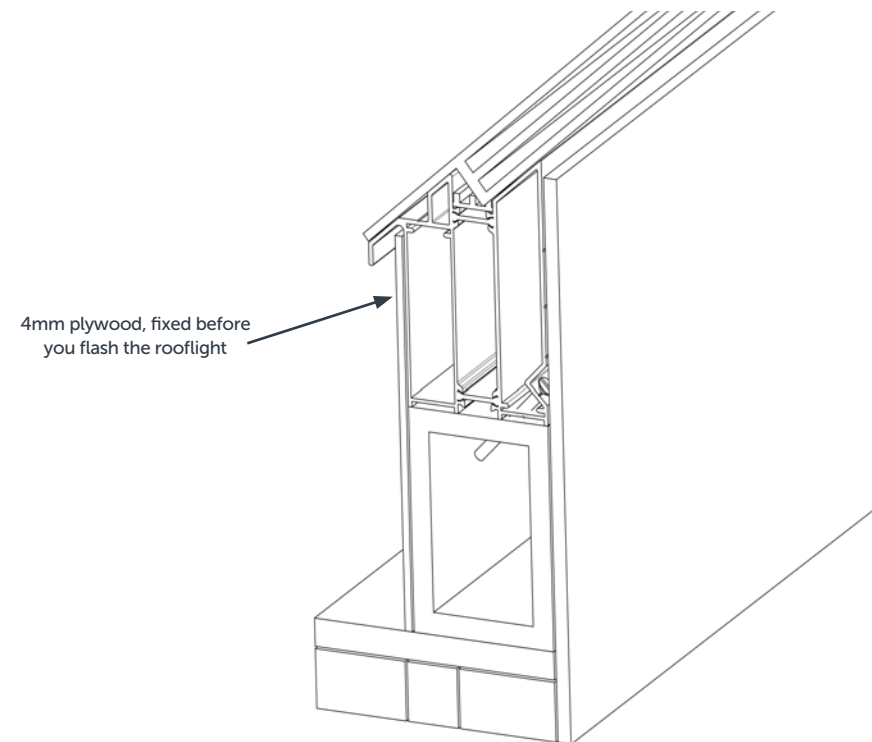

Your roof lantern assembly is now finished.

For internal plaster finishing details please refer to the cross-section fitting guide, located on page 29 of this guide.

ROOF CROSS SECTION FITTING GUIDE

The below cross section diagram illustrates how you need to finish your plastering, for units both with and without integrated blackout blinds.

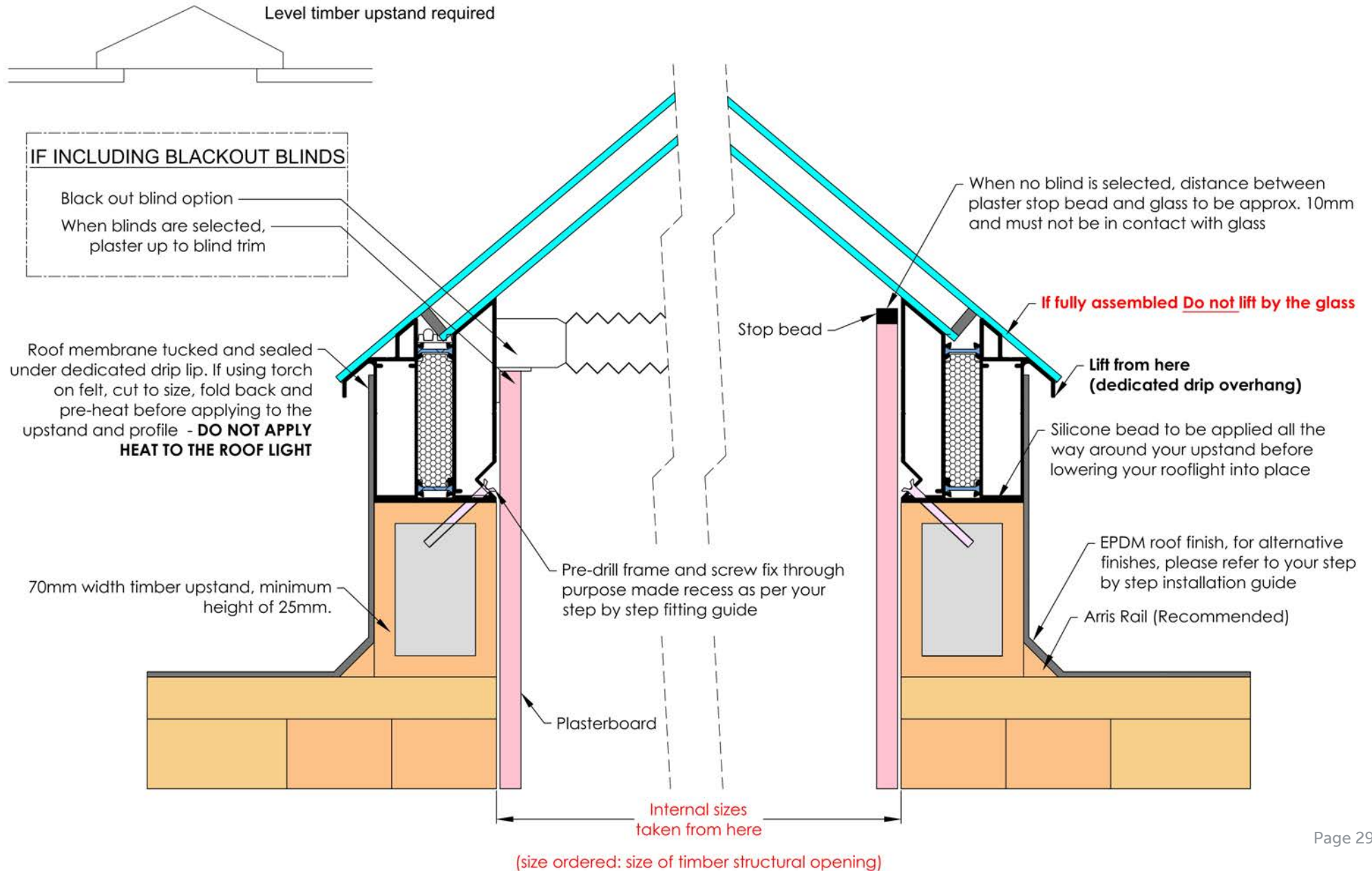

ROOF MAKER

WORLD CLASS ROOFLIGHTS

THERMOSTATIC AND RAIN CONTROLLER / OPENING VENT

The below diagrams show the wiring in process for when you have chosen a climate-controlled operation with rain sensor.

ADVANCED OPERATIONS GUIDE

The default settings of our 100 series controller are suited to most user applications.

However, if you need to make advanced alterations such as; Thermostat, Actuator and Lock Calibration, then please use the following guide.



To enter 'advanced' setup set your unit to "AUTO" mode then press and hold the **AUTO/MAN** plus **SET +/-** buttons simultaneously for 5 seconds.

Your screen should now read..

ADV
SETUP

After a moment the screen will change to display

To Advance
Press SET +/-

Using **SET +/-** is how you scroll through the available options and saves each stage of any alteration.

Now press "**SET +/-**". The screen will read..

To + a value
Press Open

The Open button is used to increase any value.

Press "**SET +/-**" again. The screen will read..

To - a value
Press Close

The Close button is used to decrease any value.

Press "**SET +/-**" again. The display will read..

Proceed to
ADV Setup

Now you can proceed to the advanced setup options.

Press "**SET +/-**" again. The display will read..

Room Temp
is now XXc

'XX' being the current temperature in your room.

By using **Open(+)** and **Close(-)** you can calibrate the display temperature.

Press "**SET +/-**" again. The display will read

Full open
Cycle 013sec

013sec is the amount of time for the motor to operate and fully open - in most cases this default setting is adequate. You can of course, alter this setting for your actuator by pressing the **Open(+)** and **Close(-)** buttons.

Press "**SET +/-**" again. The display will read..

Opening
Temp = 22c

This relates to the temperature that the room must reach before the actuator will operate.

You can alter this setting by pressing the **Open(+)** and **Close(-)** buttons.

Press "**SET +/-**" again. The display will read..

Closing
Temp = 18c

This relates to the temperature that the room must fall to before the actuator will operate.

You can alter this setting by pressing the **Open(+)** and **Close(-)** buttons.

Press "**SET +/-**" again. The display will read..

AUTO LOCK
MODE OFF

Using autolock is a security feature that prevents the unit from being used without entering a passcode first. You can turn this on or off by pressing the **Open(+)** and **Close(-)** buttons.

Press "**SET +/-**" again will take you back to **AUTO MODE**

The unlock sequence is:
Button 2 [AUTO/MAN]
Button 1 [OPEN]
Button 3 [SET +/-]
Button 4 [CLOSE]

Continued on next page...

FREQUENTLY ASKED QUESTIONS

Q. Where is the temperature sensor?

A. The Ventec 100 Series comes with an internal temperature sensor.

cleaning the metallic head with a soft damp cloth. We recommend the rain sensor is cleaned on a quarterly basis.

Q. Where do I mount my temperature sensor?

A. If you have opted for the external temperature sensor, the location is entirely at your discretion. We would recommend a position that gives a good average reading of the desired location, ideally at least 1300mm from the floor. *You can choose to position the thermostat a maximum of 30m away from the control panel.*

Q. It has recently stopped raining but my windows have not opened again?

A. In Auto mode the 100 series controller has a built in time delay of 5 minutes between the rain sensor drying and the unit becoming fully operational. This will be indicated by the presence of the Rain LED on the front panel. For the unit to operate the current temperature will need to be higher than your desired opening temperature. In manual mode you should have full control of the unit.

Q. Only the set +/- button on my panel does anything?

A. This means your panel has been locked. To unlock your unit see the instructions on the back page.

Q. My display shows 0.0 - Is this correct?

A. This indicates a problem with the thermostat wiring. Check the wiring and that all connections have been correctly made.

Q. Can I change the default lock/unlock code?

A. No. The code has been preset to avoid the need for a complete system reset should the new code be forgotten.

Q. How many actuators will the 100 series operate?

A. The 100 series has a 5 amp capacity.

Q. My rain sensor seems to have become less responsive?

A. Check the unit has not slipped or fallen into an undesired position and try

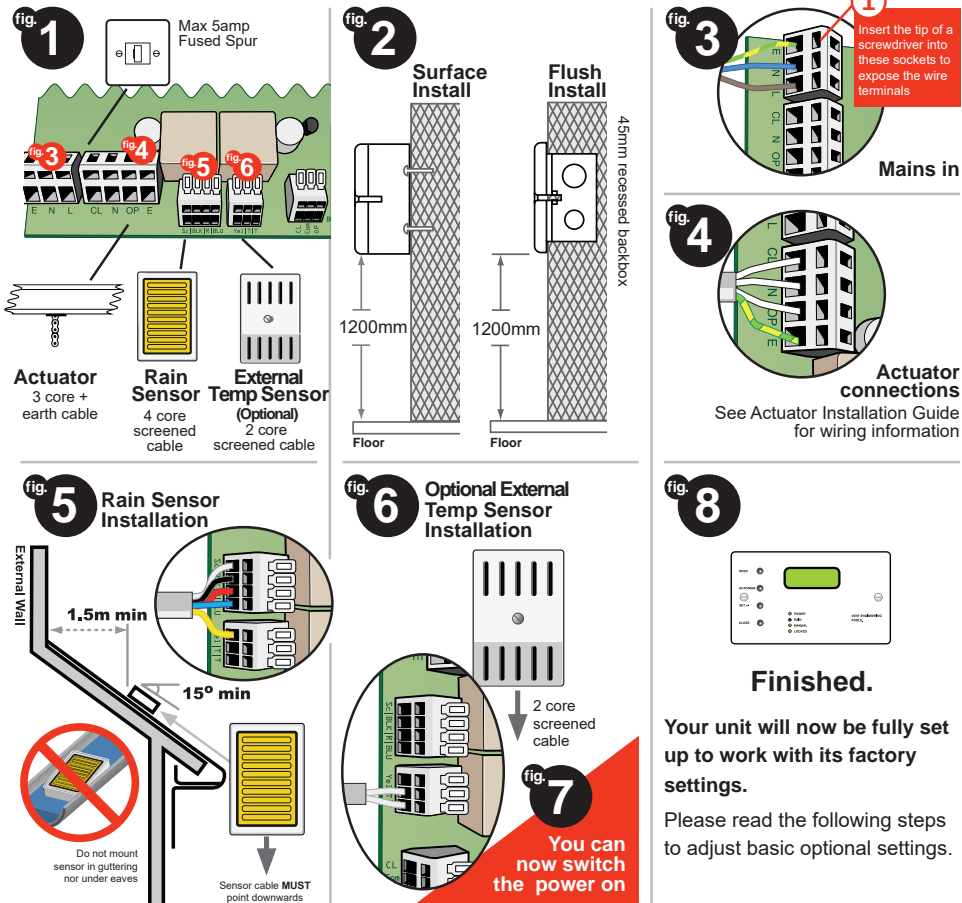

Additional user settings

Preset Opening Temperature

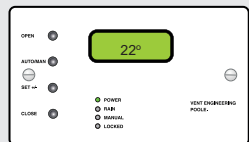

To adjust opening temperature



In Auto mode, hold 'A' & repeat press 'B'

Preset Closing Temperature



To adjust closing temperature

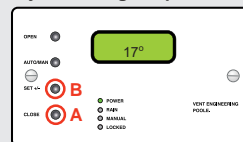

In Auto mode, hold 'A' & repeat press 'B'

We advise a difference of at least 2° between the opening and closing temperature.

To manually open and close

Press and hold **AUTO/MAN** for 2 seconds until **MANUAL** light comes on then use the **OPEN** or **CLOSE** buttons to adjust the window position.

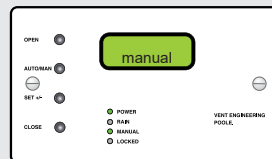

Press and hold **AUTO/MAN** for 2 seconds to return to automatic mode.

CABLE LOCATION GUIDE

SLIMLINE® ROOF LANTERNS WITH ELECTRONIC VENTS AND BLACKOUT BLINDS

INTRODUCTION AND TOOLS REQUIRED

When you have opted for a Slimline® roof lantern with electronic vent/s and a blackout blind, the electrician will need to drill through the lantern's built in upstand profile in order to run the vent motor cable through it. The requirements for this are outlined in this guide and will prevent the blind being obstructed by the vent actuator cabling, ensuring that the blind will open and close as intended.

Opening vents are always positioned on the longer sides of the lantern, so it will be the longer side of the built in upstand that you will need to prepare. If you have two vents, you will need to prepare both sides of the unit as you will have one vent positioned on each side. This preparation has to be done before the lantern is positioned and fixed to your timber kerb.

It is also necessary to notch a small groove into the inside/internal face of your kerb and reveal. This will allow the actuator cable to run into the property where it comes out of the underside of the lantern's built-in upstand. These grooves, however, can be created when the lantern is properly positioned and fixed onto the timber kerb (outlined in the guide). Tools and materials required for the preparation are as follows:

- Drill with 10mm HSS drill bit
- Tape measure and pencil
- 2x 10mm rubber grommets (per vent), suitable for a 2mm wall thickness – ensure the grommets have a large enough hole to comfortably run the motor cable through them
- Hammer and chisel or routing tool (to create the internal groove/s required in the timber structure, for the cabling to run into the property)
- Masking tape (optional)

CABLE LOCATION GUIDE

SLIMLINE® ROOF LANTERNS WITH ELECTRONIC VENTS AND BLACKOUT BLINDS

PREPARATION GUIDE FOR FLAT PACKED LANTERNS

When you have received a flat packed Slimline® roof lantern, the upstand section will be fully assembled and already house the blackout blind. The blind will be fully open and you will see that it sits along the width of the unit, at the side that it would retract to. If you have a single vent, you will need to make a decision at this point as to which side you would like the opening vent to be positioned, which will always be positioned in the centre, on the longer side of the rooflight. The side you locate the vent is down to your preference. If you have two vents, there will be one positioned on either side of the unit, centred on each of the longer sides.

STEP 1

On the (longer) side you have chosen for your vent to be located, measure the upstand section from the inside corner to inside corner. Use this measurement to then find the centre point of the long side. Make a mark at this centre point, close to the top edge of the profile, above the white blind trim.

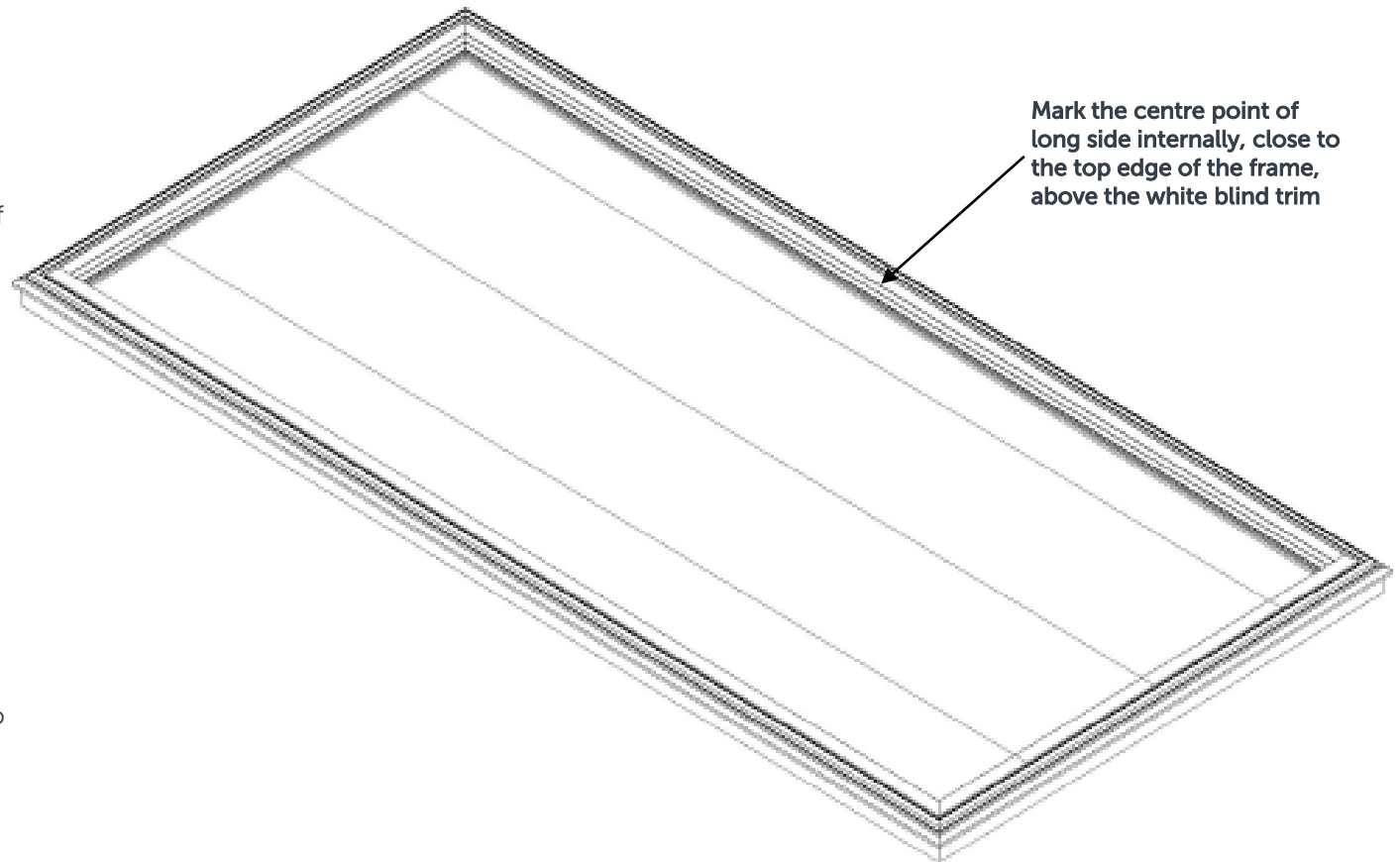

Mark the centre point of long side internally, close to the top edge of the frame, above the white blind trim

CABLE LOCATION GUIDE

SLIMLINE® ROOF LANTERNS WITH ELECTRONIC VENTS AND BLACKOUT BLINDS

STEP 2

Looking toward the internal face of the upstand, measure to the right of your centre mark by 200mm, making another mark here, close to the top edge.

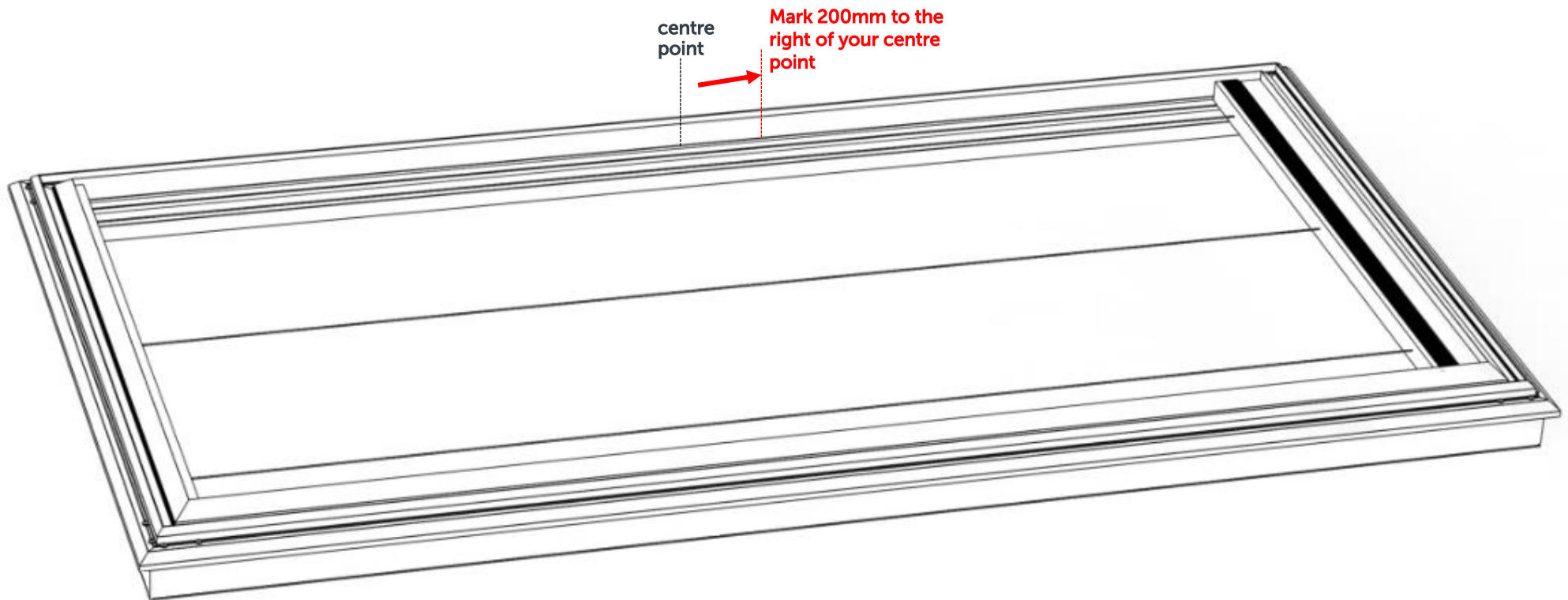

CABLE LOCATION GUIDE

SLIMLINE® ROOF LANTERNS WITH ELECTRONIC VENTS AND BLACKOUT BLINDS

STEP 3

At your 200mm mark, measure down from the top edge of the profile by 15mm and make a mark. Where the two marks meet, use your 10mm drill bit to drill a hole. Take your time and ensure that the hole is only made in this surface and doesn't go through any deeper.

Tip – you can place masking tape onto the frame where the hole needs to be drilled, which will stop the drill slipping and also prevent the powder coating from chipping in this area.

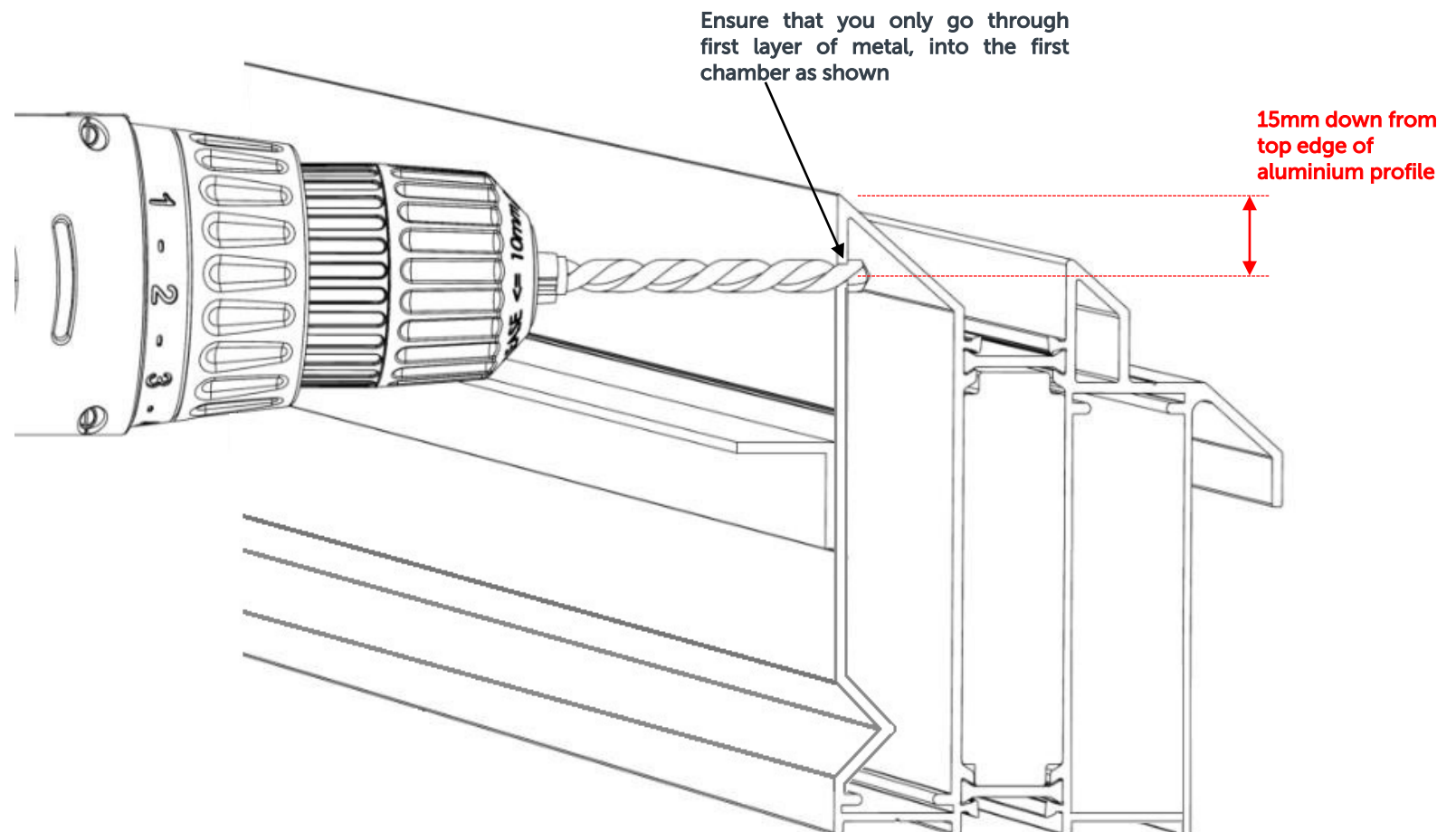

CABLE LOCATION GUIDE

SLIMLINE® ROOF LANTERNS WITH ELECTRONIC VENTS AND BLACKOUT BLINDS

STEP 4

You now need to drill a 10mm hole through the bottom of the upstand, vertically level with the first hole you made on the inside face, through to the inside chamber of the upstand.

You can also use the masking tape here to prevent the drill slipping, as mentioned in the previous step.

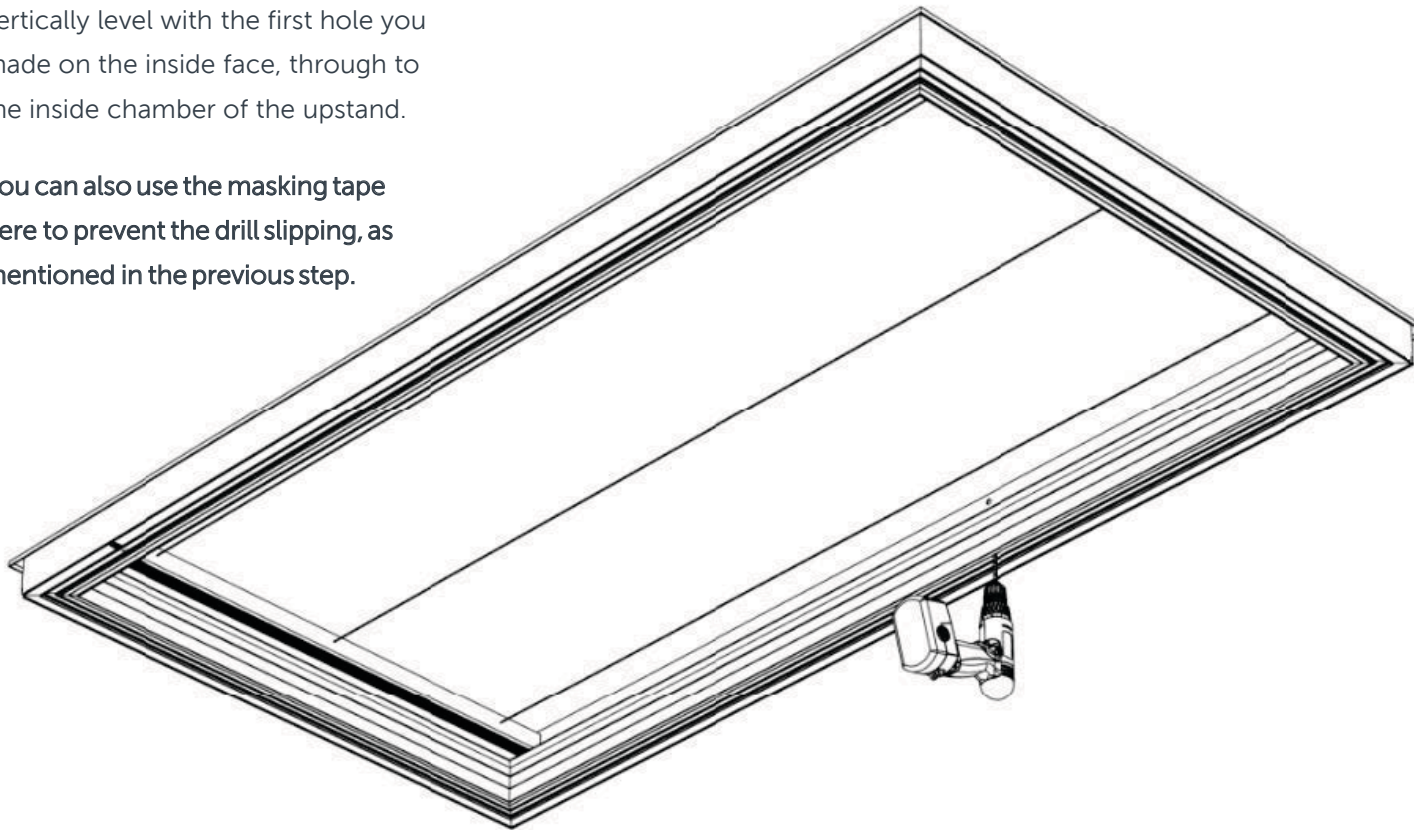

You will be drilling into the first chamber again, as shown, vertically in line with the first hole you drilled.

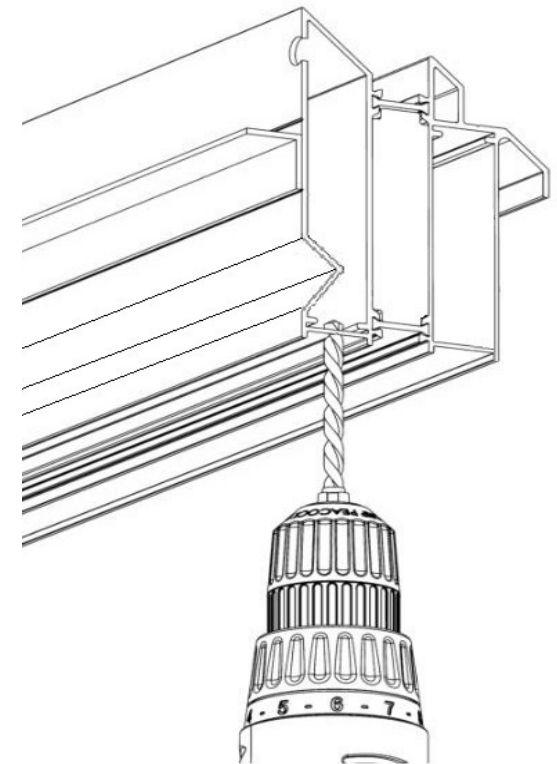

CABLE LOCATION GUIDE

SLIMLINE® ROOF LANTERNS WITH ELECTRONIC VENTS AND BLACKOUT BLINDS

STEP 5

Place the rubber grommets into both holes you have just drilled. If you have two vents, repeat this process on the opposite side of the roof lantern following the same instructions. The upstand section is now prepared.

The installers can now fix the upstand to the timber kerb as advised in the step by step installation guide and proceed to assemble the rest of the roof lantern. When the lantern installation is complete, proceed to the next step.

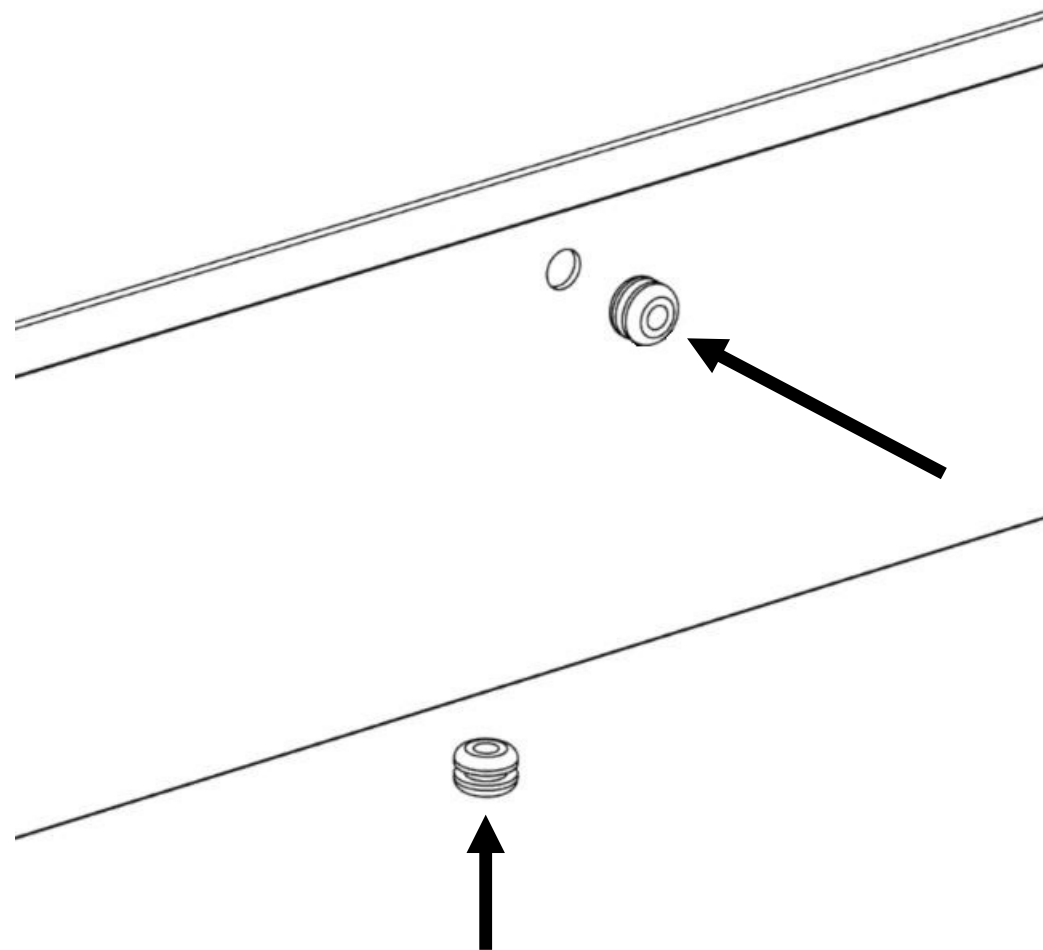

CABLE LOCATION GUIDE

SLIMLINE® ROOF LANTERNS WITH ELECTRONIC VENTS AND BLACKOUT BLINDS

STEP 6

Now the lantern is installed, you can create the groove/s required in the timber reveals, to house the vent actuator cabling. Mark a line down the timber reveal, vertically level with the grommet's position. Use the line as a guide to notch a groove into the timber structure. This will house the cabling when it is fed through the upstand, and allow it to run into the property. Ensure the groove is deep enough to expose the hole you have prepared in the bottom of the upstand and house the cable sufficiently, so it will not obstruct the plasterboard when applied to the reveals later on.

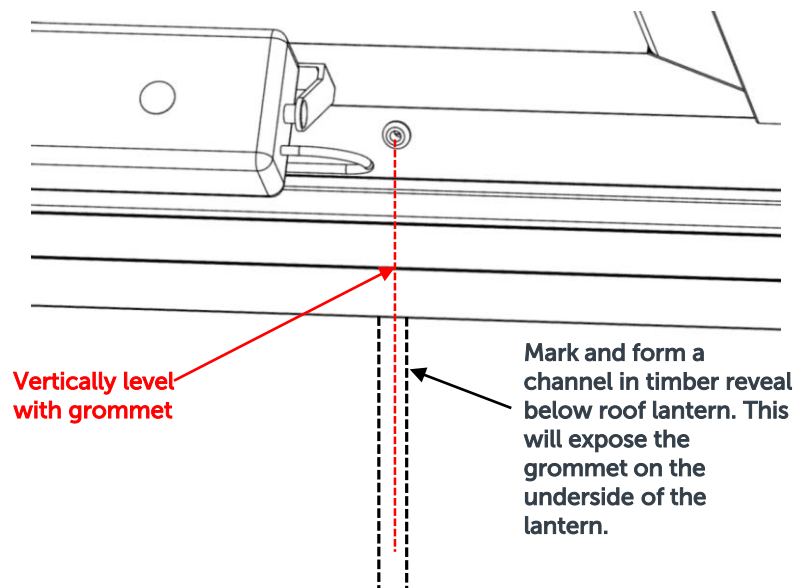

STEP 7

You can now run the cable that comes from the vent actuator through the hole in the upstand frame above the blind trim, out through the bottom of the unit and into the groove you have formed in the reveal. You will need to extend the cable to the chosen location of your rocker switch/climate control panel. Once the vent has been fully wired in and checked, the installer can then proceed to plaster the inside reveals, as per the finishing guidelines shown in the installation guide. **Be sure to instruct the installer not to put plasterboard fixings where the cabling is located in the reveal.**

